



Dynaxe – Setting The Standard

Wouter Witzel EuroValve

double eccentric high performance butterfly valve

Dynaxe sets the new standard for double-offset butterfly valves. It is the result of an integrated design approach to lift this technology onto an even higher level of performance, with a multitude of new and optimized features complementing each other. Special emphasis was put on a flexible product design enabling an exact finishing according to customer specifications.

The resulting technical and economical advantages of the precise and proven Dynaxe technology have led to an improved life cycle as well as higher productivity and security - guaranteed customer satisfaction!



Who We Are

Wouter Witzel EuroValve is the specialist for High Performance butterfly valves, with a proven track record as part of the AVK Group. Innovative products such as Dynaxe have secured the company's technological leadership in the market.

Renowned as the producer and supplier with the most complete range of fluid management solutions, Wouter Witzel EuroValve operates from sales offices all around the world. A strong customer relationship is ensured as Wouter Witzel Eurovalve expert technicians and consultants are always close-by, no matter where the expertise is needed. The production facilities employ the latest technology for the design and manufacturing of valves, pumps and instruments for the industrial, commercial, municipal and utility markets.

Dynaxe Features

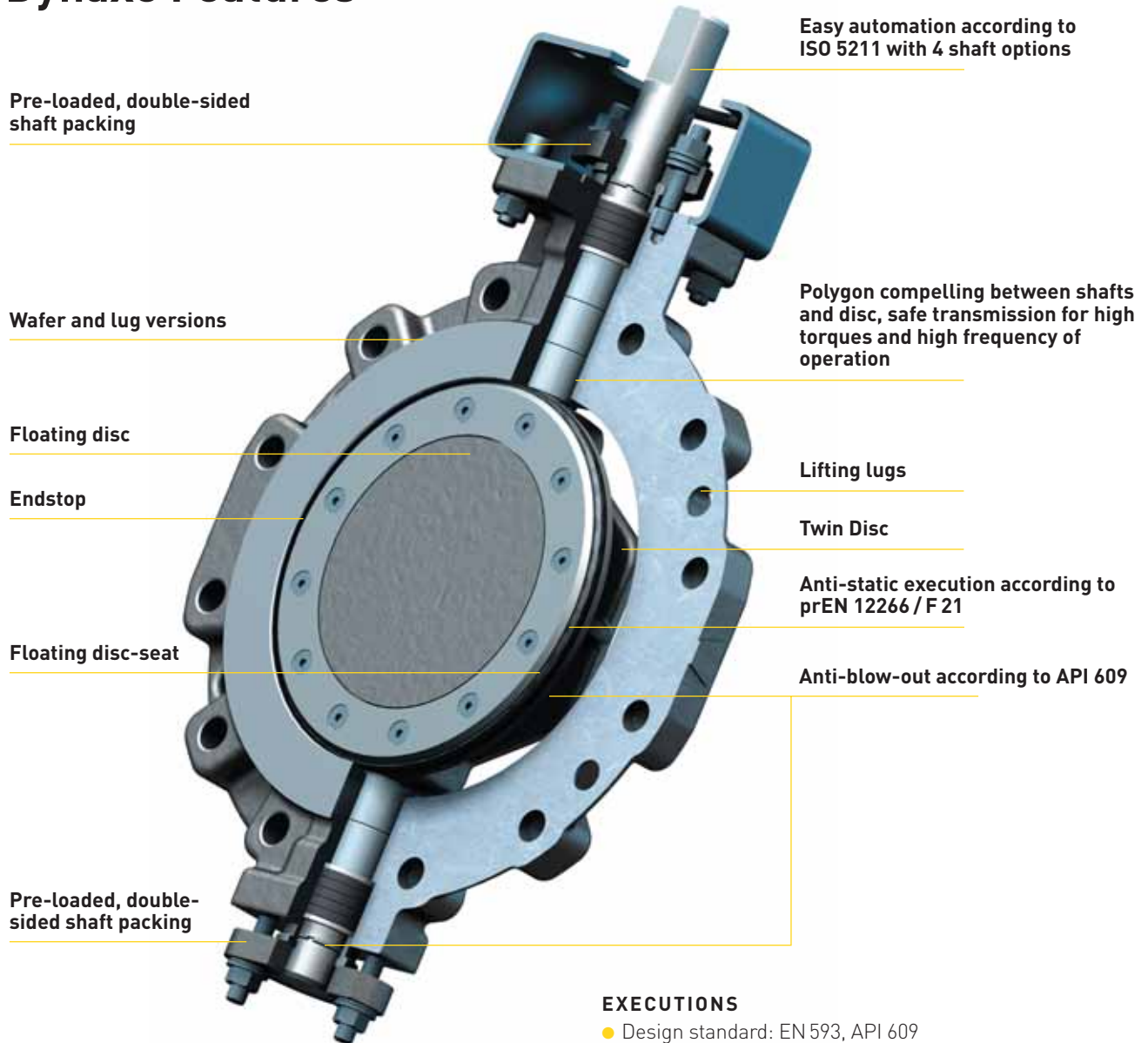

Pre-loaded, double-sided shaft packing

Easy automation according to ISO 5211 with 4 shaft options

Wafer and lug versions

Polygon compelling between shafts and disc, safe transmission for high torques and high frequency of operation

Floating disc

Lifting lugs

Endstop

Twin Disc

Floating disc-seat

Anti-static execution according to prEN 12266 / F 21

Pre-loaded, double-sided shaft packing

Anti-blow-out according to API 609

MARKET SEGMENTS

- Oil and gas processing
- Offshore platforms
- Petrochemical refineries
- Tank storage transportation
- Heating, ventilation, air conditioning (HVAC)
- District heating
- Shipbuilding
- Power generation
- Chemical plants
- Steel plants
- Paper and pulp

EXECUTIONS

- Design standard: EN 593, API 609
- Types in wafer and lug, double flanged on request
- Standard sizes: DN 50/2" – DN 900/36", larger sizes on request
- Flange connections: PN 10/16/25/40, ANSI class 150/300
- Face to face dimensions: according to EN 558-1/2, ISO 5752, API 609
- Materials: Carbon Steel, Stainless Steel, Titanium, Hastelloy, Uranus B 6, Duplex, 6 Mo and NiAl-Bronze
- Disc-seats: RTFE soft seated, fire-safe and metal-to-metal.

OPERATING CONDITIONS

- Operating pressure max. 50 bar
- Temperature range -29 °C to +540 °C, depending on medium and material choice
- Pressure-temperature rating according to ASME 16.34 and API 609, ISO 7005
- Zero-leakage according to ISO 5208 rate A
- In compliance with Pressure Equipment Directive (PED)

Advanced Double-Off-Set Technology

At first glance, Dynaxe is a typical double-off-set design with an off-set off the disc-seat and an off-set off the stem. One of its outstanding features though reveals itself on closer inspection. In contrast to the majority of existing designs the disc-seat of the Dynaxe valve is applied on the disc and not on the body, resulting in numerous advantages:

- Better tightness, throughout one-piece body
- Higher safety
- Economical design
- Reduced number of required components

A corrosion-free shut-off operation is ensured at all times by the welded Mn-alloyed overlay seat of the valve-body, thus guaranteeing a long service life. The standard overlay is made of Mn-alloyed-stainless-steel although other overlays like Stellite® are also available.

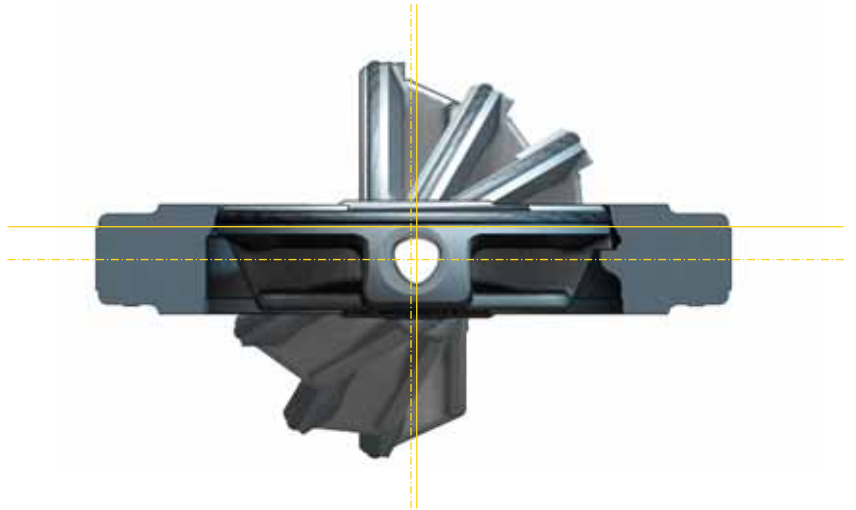

The Zero Leakage Solution

Benefit from the Dynaxe zero leakage solution for pressures of up to 50 bar and – depending on the valve material – a temperature range of –29 to 540 °C. Each disc-seat option is tested according to ISO 5208 Rate A, providing maximum security. Even the highest leakage rate requirements are met and several specifications exceeded. All soft-seated and fire-safe Dynaxe executions provide a bi-directional service. The metal-to-metal disc-seat is tested uni-directional.

THE DYNAXE STANDARD:

**ISO 5208 Rate A
ZERO LEAKAGE**

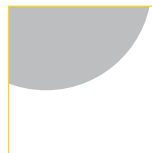

Dynaxe Test Standard	Allowable Seat Leakage	
	in ml/min	in drops
ISO 5208, rate A	0	0

OTHER STANDARDS:

Other Test Standards	Allowable Seat Leakage	
	in ml/min	in drops
ISO 5208, rate B	0.12	2
ISO 5208, rate C	0.36	6
ISO 5208, rate D	1.2	19
ANSI-FCI 70-2, cl. V	1.16	19
API 598 (metal seated)	1.25	20

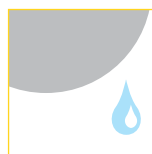

Anti-Static Design

Due to their sophisticated design, all Dynaxe double-off-set butterfly valves are inherently anti-static according to EN 12266-F21. They also meet the requirements of the chemical and petrochemical industries.

Even all RTFE seats are conductable due to the combination of RTFE and carbon.

1 ml = 16 drops, according to API 598 7th ed.
Test valve DN 200/8", test pressure 20 bar

Standard Seats



RTFE (TH)

- PTFE reinforced, filled with glass, carbon, graphite, and a Helix coil energizer.
- Temperature range: -29°C to 204°C
- RTFE TH is the most used disc-seat and suitable for a multitude of applications and high cycle frequencies.



FIRE-SAFE (FS)

- PTFE reinforced, filled with glass, carbon, graphite and a Helix coil energizer. Additionally, a metal back ring assures tightness under fire conditions.
- Temperature range: -29°C to 204°C
- Fire-safe tested according to API 607 ed. 5. ISO 10497.



METAL LAMINATED (M)

- Laminated metal seal made of stainless steel and pure graphite.
- C-ring in Inconel X-750 as energizer and back-up sealing.
- Sinus-spring self-aligning.
- Temperature range: -29°C to 425°C
- A typical execution for especially high temperature applications.
- Fire-safe tested according to BS 6755 part 2.



METAL SOLID (MS)

- C-ring in Inconel X-750 as energizer and back-up sealing.
- Sinus-spring self-aligning.
- The solid metal seal is available in three different materials to extend the range of applications:

1. Stainless Steel with DLC

- Temperature range: -29°C to 425°C
- DLC = Diamond-like carbon coating.
- Special solutions for regulation and the resulting high flow velocity for steam and gas applications.

2. PAN-Bronze

- Temperature range: -29°C to 300°C
- Special solutions for regulation and the resulting high flow velocity for steam and gas applications.

3. Inconel X 750

- Temperature range: -29°C to 540°C
- Withstands extreme temperature stress and meets other special requirements.

Remark: Low temperature and cryogenic services of up to -196°C possible on request.



Two Packings For A Floating Disc

All Dynaxe valves feature two packing systems as a standard, one at the upper and the other at the lower shaft. This is in stark contrast to most other butterfly valves, which use only one static sealing (cap) at the lower shaft. The modern Dynaxe double-sided packing design not only offers more security, it also provides for a maximum flexibility system with a floating disc. The advantages of this special packing principle are clear especially under high loads, e. g. major temperature changes with a resulting expansion of the material.

The packing glands as well as the gland flanges are spherically wrought. Thus, they are self-aligning, resulting in a constant pressure load on the packings. Additionally, adjustments are not necessary, as the system is under constant tension due to the springs being used. As the Dynaxe disc-seat system is self-centering, a jamming of the disc is securely avoided at all times.

In the standard execution of the Dynaxe butterfly valve, the packings are made of pure graphite (99.8%). With this material, a wide spectrum of applications is covered, even under high temperature and fire-safe requirements.

The two-sided stuffing box provides a total force and temperature compensation.



Optimized Flow Through Twin Disc

The Twin Disc of the Dynaxe valve is the result of intensive research and development. It is especially designed to optimize the flow characteristics of fluid handling systems. Resembling a framework, its design adds further advantages to the valve:

- Increased Kv/Cv value
- Operation with lower energy costs
- Lower weight
- Minimized bending of the disc
- Thermo-shock resistance
- Quick heating-up to operating temperature



Superior Polygon Design

Another enhancing feature of the Dynaxe butterfly valve is its polygon stem, which has a harmonic trilobed profile P3G according to the German standard DIN 32711. With this polygon joint – a positive fit shaft hub joint – the torque is transmitted directly without using additional elements (e. g. keys). Being superior to other shaft hub designs, the polygon joint provides several advantages:

- Optimized transmission of torque
- Simple assembly and disassembly
- Small stress peaks due to the smooth and convex shaped profile
- Orbiform curve
- Higher load bearing capacities
- Self-centering under torsional load
- Longer service-life
- Guaranteed safe operation

Easy Actuator Automation

A key feature of the Dynaxe valves is their easy automation, as they are in full accordance with ISO 5211 (flange-shaft combination). All known versions are available, which provides excellent flexibility for the assembly of different types of actuators (see pictures). Adapters and additional brackets are completely unnecessary, with the result being a much better tolerance level. The company standard of the Dynaxe, without any individual customer specifications being taken into account, is as listed in the table below.

Male connection to the bracket is according to the requirements of the chemical industry.

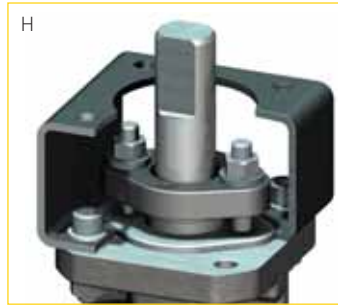

Flat-head shaft



Shaft with key



Square shaft, parallel



Square shaft, diagonal

Flange dimension	Rating	Size	ISO 5211
≤F 12	PN 10/16, ANSI 150	DN 50/2"-DN300/12"	H (Double-flat shaft)
	PN 25/40, ANSI 300	DN 50/2"-DN 200/8"	
≥F 14	PN 10/16, ANSI 150	≥DN 350/14"	V or W (Shaft with key)
	PN 25/40, ANSI 300	≥DN 250/10"	



Anti Blow-Out

Two key standards define the requirements for the design of anti blow-out safeguards: EN 736/3 and API 609. Although their contents differ, Dynaxe butterfly valves meet them both. To achieve this, two anti blow-out safeguards are applied. One internally, a screw at the connection of the polygon shaft with the disc – the other externally, an anti blow-out device at the outer part of the shaft on level with the stuffing box.

A Class Of Its Own

The Dynaxe double eccentric butterfly valve is not just a precise and proven technology – all its designs are also in accordance with the relevant standards throughout the world, approved and certified by renowned testing bodies and institutes (see examples). Thus, EuroValve customers are able to benefit from the Dynaxe advantages no matter where in the world the valve is to be used. Both internal and external controls permanently guarantee the constant high level of quality.



TECHNICAL STANDARDS

- Quality assurance
- Basic design
- Marking
- Flange connections
- Face to face dimensions
- Fire tested design
- Testing
- Seat leakage rate
- Part-turn actuator attachment
- Pressure-temperature-rating
- PED
- Fugitive emissions
- Anti-blow-out
- Anti-static
- Code AD 2000

- ISO 9001
- EN 593, ASME B16.34, API 609, DIN 3840, prEN 12516-2
- ISO 5209, EN 19, MSS SP-25, API 609
- ISO 7005, EN 1092, ASME B16.5/B16.47, MSS SP-44, DIN 2501
- ISO 5752, EN 558, ASME B16.10, API 609
- API 607 4th Ed., BS 7655, part 2
- API 598, EN 12266, DIN 3230 Part 3
- ISO 5208 Rate A, ANSI FCI 70-2, Class VI, DIN 3230 BA, BN 1
- ISO 5211
- ASME B16.34, ISO 7005, API 609
- PED 97/23/EC (category III) modul H
- ISO/CD 15848-1
- EN 736/3, API 609
- EN 12266/F21
- AD-A4

Technical Data

- | | |
|---------------------------|-------------------------|
| 1: BODY | 6. GLAND (top & bottom) |
| 2: DISC | 7: BEARING |
| 3: SEAT RING (Type TH) | 8: ANTI-BLOW OUT |
| 4: SHAFT | 9: BRACKET |
| 5: PACKING (top & bottom) | 10: TAGGING |

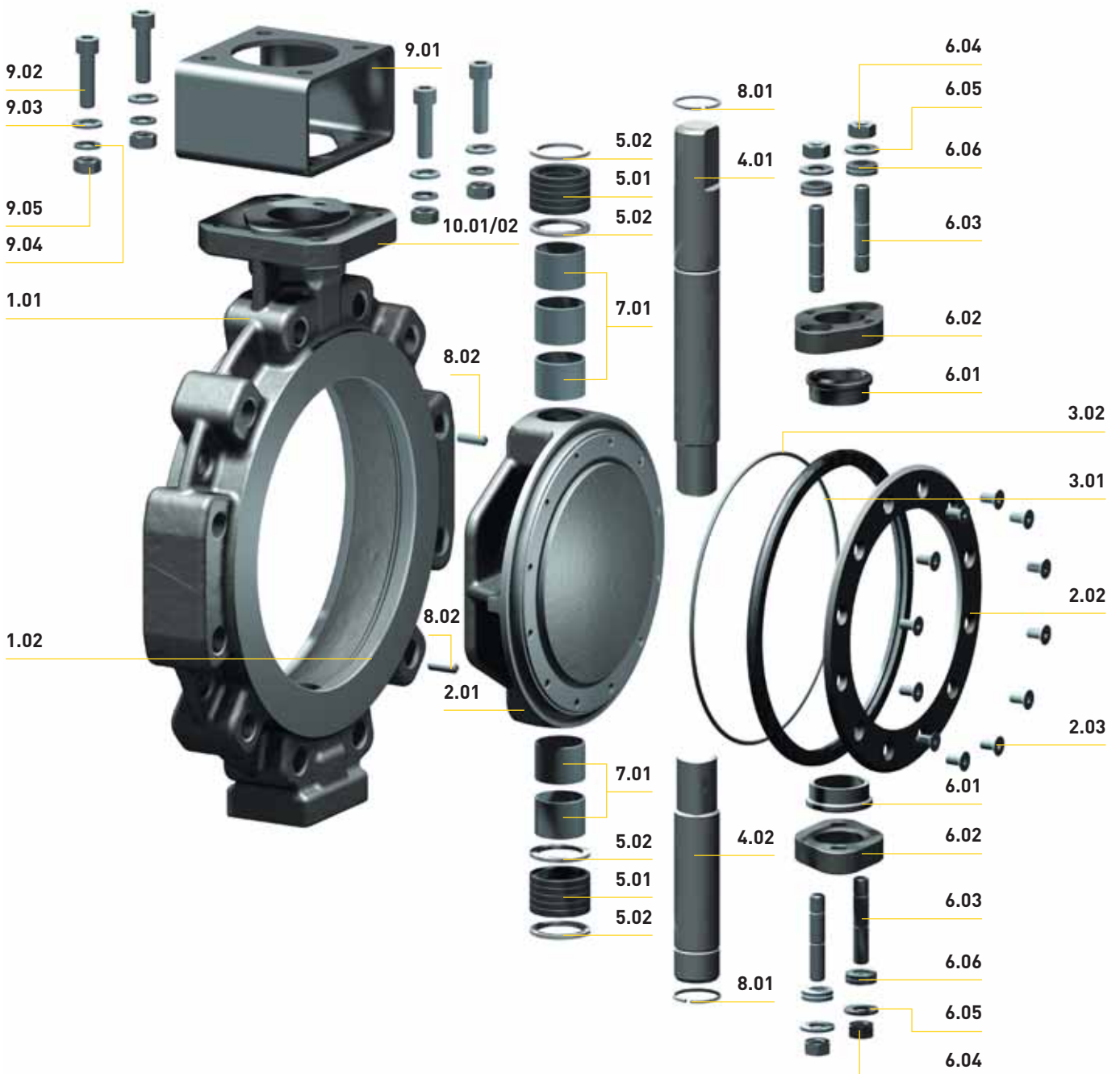

BASIC CONFIGURATION

Items	Description	Carbon / Carbon / RTFE TH	Carbon / Stainl. Steel / RTFE TH	Stainl. Steel / Stainl.Steel / RTFE TH
1.01	BODY	1.0619 (ASTM A216 WCB)	1.0619 (ASTM A216 WCB)	1.4408 (ASTM A351 CF8M)
1.02	BODY SEAT	Stainless Steel 1.4370	Stainless Steel 1.4370	1.4408 (ASTM A351 CF8M)
2.01	DISC FORGED	1.0460 (ASTM A105 N)	1.4401 (ASTM A182 F316)	1.4401 (ASTM A182 F316)
	DISC CASTED	1.0619 (ASTM A216 WCB)	1.4408 (ASTM A351 CF8M)	1.4408 (ASTM A351 CF8M)
2.02	RETAINING RING	1.4401 (AISI 316)	1.4401 (AISI 316)	1.4401 (AISI 316)
2.03	SCREW (DIN 7991)	Stainless Steel A4/70	Stainless Steel A4/70	Stainless Steel A4/70
3.01	DISC SEAT RING (TH)	RTFE 15-12-3	RTFE 15-12-3	RTFE 15-12-3
3.02	HELIX COIL	1.4401 (AISI 316)	1.4401 (AISI 316)	1.4401 (AISI 316)
4.01	UPPER SHAFT	1.4021 (ASTM A276 420)	1.4021 (ASTM A276 420)	1.3964 (ASTM A479 XM-19)
4.02	LOWER SHAFT	1.4021 (ASTM A276 420)	1.4021 (ASTM A276 420)	1.3964 (ASTM A479 XM-19)
5.01	PACKING RING	Graphite (> 99.85%)	Graphite (> 99.85%)	Graphite (> 99.85%)
5.02	TAPER RING	1.4401 (AISI 316)	1.4401 (AISI 316)	1.4401 (AISI 316)
6.01	PACKING GLAND	1.4408 (ASTM A351 CF8M)	1.4408 (ASTM A351 CF8M)	1.4408 (ASTM A351 CF8M)
6.02	GLAND FLANGE	1.4408 (ASTM A351 CF8M)	1.4408 (ASTM A351 CF8M)	1.4408 (ASTM A351 CF8M)
6.03	STUD BOLT (DIN 939)	Stainless Steel A4/70	Stainless Steel A4/70	Stainless Steel A4/70
6.04	HEXAGONAL NUT (DIN 934)	Stainless Steel A4/70	Stainless Steel A4/70	Stainless Steel A4/70
6.05	WASHER (NF E25-513)	Stainless Steel A4	Stainless Steel A4	Stainless Steel A4
6.06	BEVELED WASHER (DIN 2093)	Stainless Steel	Stainless Steel	Stainless Steel
7.01	SLIDING BEARING	1.4401 (AISI 316 / Coated)	1.4401 (AISI 316 / Coated)	1.4401 (AISI 316 / Coated)
8.01	SNAP RING (DIN 7993)	Stainless Steel 1.4310	Stainless Steel 1.4310	Stainless Steel 1.4310
8.02	SET SCREW (DIN 916)	Stainless Steel A4/70	Stainless Steel A4/70	Stainless Steel A4/70
9.01	BRACKET	1.4571 (AISI 316Ti)	1.4571 (AISI 316Ti)	1.4571 (AISI 316Ti)
9.02	SCREW (DIN 912)	Stainless Steel A4/70	Stainless Steel A4/70	Stainless Steel A4/70
9.03	WASHER (DIN 125)	Stainless Steel A4/70	Stainless Steel A4/70	Stainless Steel A4/70
9.04	SPRING LOCK WASHER (DIN 127)	Stainless Steel A4/70	Stainless Steel A4/70	Stainless Steel A4/70
9.05	HEXAGON NUT (DIN 934)	Stainless Steel A4/70	Stainless Steel A4/70	Stainless Steel A4/70
10.01	MARKING PLATE	1.4401 (AISI 316)	1.4401 (AISI 316)	1.4401 (AISI 316)
10.02	BLIND RIVET (DIN 7337 A)	Stainless Steel A4	Stainless Steel A4	Stainless Steel A4

THE OPTIONAL DISC SEATS

Items	Description			
RTFE Fire Safe Design (TF)				
3.01	DISC SEAT RING	RTFE 15-12-3	RTFE 15-12-3	RTFE 15-12-3
3.02	HELIX COIL	Stainless Steel	Stainless Steel	Stainless Steel
3.03	FIRE SAFE SEAT RING	AISI 316 / 316 Ti	AISI 316 / 316 Ti	AISI 316 / 316 Ti
Metal Laminated Seat (M)				
3.01	DISC SEAT RING	AISI 316 / 316 Ti + Graphite	AISI 316 / 316 Ti + Graphite	AISI 316 / 316 Ti + Graphite
3.02	C-RING	INCONEL 718	INCONEL 718	INCONEL 718
3.03	SINUS-SPRING	Stainless Steel	Stainless Steel	Stainless Steel
Metal Solid Seat Stainless Steel (MS)				
3.01	DISC SEAT RING	AISI 316 DLC-Coated	AISI 316 DLC-Coated	AISI 316 DLC-Coated
3.02	C-RING	INCONEL 718	INCONEL 718	INCONEL 718
3.03	SINUS-SPRING	Stainless Steel	Stainless Steel	Stainless Steel
Metal Solid Seat Bronze (MS)				
3.01	DISC SEAT RING	PAN-Bronze	PAN-Bronze	PAN-Bronze
3.02	C-RING	INCONEL 718	INCONEL 718	INCONEL 718
3.03	SINUS-SPRING	INCONEL	INCONEL	INCONEL
Metal Solid Seat Inconel (MS)				
3.01	DISC SEAT RING	INCONEL	INCONEL	INCONEL
3.02	C-RING	INCONEL 718	INCONEL 718	INCONEL 718
3.03	SINUS-SPRING	INCONEL	INCONEL	INCONEL



MAIN DIMENSIONS

Wafer execution with gear and handwheel

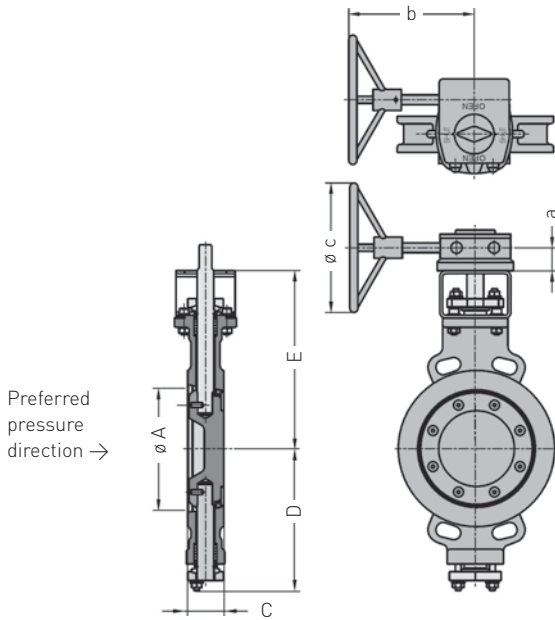

Lug execution with gear and handwheel

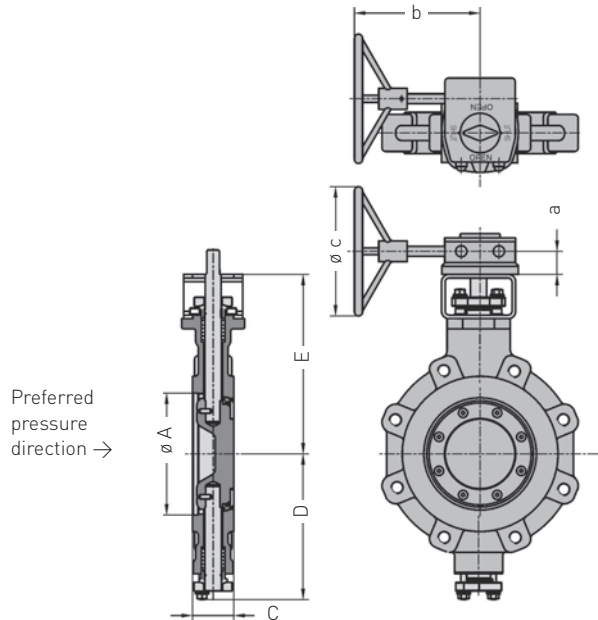

Bare shaft dimensions

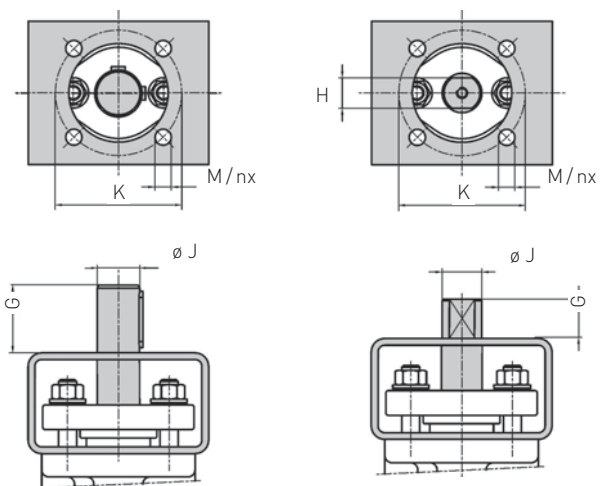

DYNAXE CLASS 150					GEAR MASTERGEAR M-SERIES AND M.F-SERIES				HAND LEVER			BARE SHAFT					
DN	A	C	D	E	Type	a	b	c	Type	a	b	G	H	J	K	M	n
50	75	43	139	190	M05 SG200	26.5	192	200	R5	52	270	25	14	18	50	7	4
65	75	46	139	190	M05 SG200	26.5	192	200	R5	52	270	25	14	18	50	7	4
80	88	46	146	197	M05 SG200	26.5	192	200	R5	52	270	25	14	18	50	7	4
100	112	52	170	216	M07 SG200	26.5	192	200	R7	57	325	28	17	22	70	9	4
125	137	56	182	228	M07 SG200	26.5	192	200	R7	57	325	28	17	22	70	9	4
150	165	56	196	242	M07 SG200	26.5	192	200	R7	57	325	28	17	22	70	9	4
200	213	60	240	301	M10 SG200	35	202	200				37,5	22	28	102	11	4
250	267	68	279	334	M12 SG400	42	348	400				46	27	36	125	13	4
300	317	78	311	371	M12 SG400	42	348	400				46	27	36	125	13	4
350	346	92	358	427	M14 SG500	50	375	500				65	-	42	140	17	4
400	398	102	384	453	M14 SG500	50	375	500				65	-	42	140	17	4
450	452	114	493	525	M15 SG600	50	477	600				80	-	60	165	21	4
500	503	127	519	551	M15 SG600	50	477	600				80	-	60	165	21	4
600	603	154	598	688	MFF57/S3 SG600	66	608	600				110	-	72	254	17	8
700	705	165	648	738	MFF57/S5 SG500	66	558	500				110	-	72	254	17	8
750	755	165	724	812	MJF50/S5 SG600	65	640	600				130	-	80	298	21	8
800	805	190	749	837	MJF50/S5 SG600	65	640	600				130	-	80	298	21	8
900	905	203	799	887	MJF50/S5 SG600	65	640	600				130	-	80	298	21	8

DYNAXE CLASS 300					GEAR MASTERGEAR M-SERIES AND M.F-SERIES				HAND LEVER			BARE SHAFT					
DN	A	C	D	E	Type	a	b	c	Type	a	b	G	H	J	K	M	n
50	75	43	139	190	M05 SG200	26.5	192	200	R5	50	215	25	14	18	50	7	4
65	75	46	139	190	M05 SG200	26.5	192	200	R5	50	215	25	14	18	50	7	4
80	88	64	157	204	M07 SG200	26.5	192	200	R7	63	345	28	17	22	70	9	4
100	112	64	170	216	M07 SG200	26.5	192	200	R7	63	345	28	17	22	70	9	4
125	137	70	202	263	M10 SG200	35	202	200				37,5	22	28	102	11	4
150	165	76	217	278	M10 SG200	35	202	200				37,5	22	28	102	11	4
200	213	89	252	307	M12 SG400	42	348	400				46	27	36	125	13	4
250	267	114	319	388	M14 SG500	50	375	500				65	-	42	140	17	4
300	317	114	343	413	M15 SG500	50	427	500				65	-	42	140	17	4
350	346	127	441	473	MFF57 / S3 SG400	66	548	400				80	-	60	165	21	4
400	398	140	495	585	MFF57 / S3 SG600	66	608	600				110	-	72	254	17	8
450	452	152	521	611	MFF57 / S5 SG500	66	558	500				110	-	72	254	17	8
500	503	152	550	642	MFF36 / S5 SG600	66	608	600				110	-	72	254	17	8
600	603	178	640	728	MJF50 / S5 SG600	65	640	600				130	-	80	298	21	8

STANDARD EXECUTION WAFER AND LUG CLASS 150 LBS

DN (mm)	Size (inch)	Kv / Cv-value relating to the face-to-face dimension			Kv / Cv-value according to EN1267		
		Kva value (m ³ / h) at ΔP=1 bar	Cva value in US gallons / min at ΔP=1 psi	ζ	Kva value (m ³ / h) at ΔP=1 bar	Cva value in US gallons / min at ΔP=1 psi	ζ
50	2"	92	107	1.3	68	79	2.4
65	2 1/2"	100	116	4.0	86	100	3.0
80	3"	155	180	4.1	119	138	2.4
100	4"	385	447	1.2	283	328	2.1
125	5"	652	756	0.9	492	571	1.7
150	6"	1234	1431	0.6	1001	1161	0.9
200	8"	2224	2580	0.5	1828	2120	0.8
250	10"	4007	4648	0.4	3491	4050	0.5
300	12"	6262	7264	0.4	5556	6445	0.5
350	14"	6926	8034	0.4	6021	6984	0.6
400	16"	10011	11613	0.4	8963	10397	0.4
450	18"	11914	13820	0.4	10425	12093	0.5
500	20"	15429	17898	0.4	13689	15879	0.5
600	24"	21224	24620	0.4	18754	21755	0.5

KV AND CV VALUE DIAGRAM
DYNAXE CLASS 150 LBS / PN 20

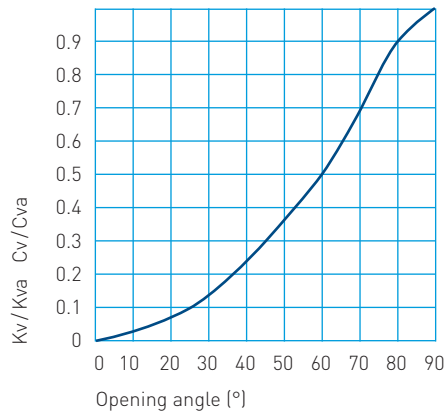

KV AND CV VALUE DIAGRAM
DYNAXE CLASS 300 LBS / PN 50

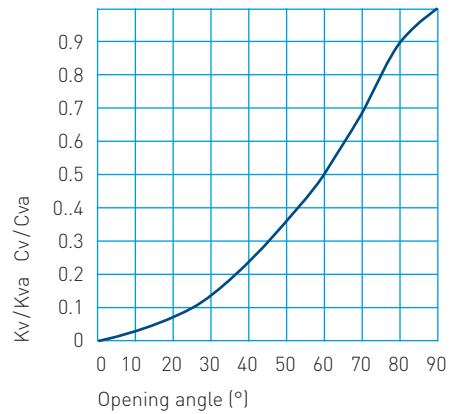

STANDARD EXECUTION WAFER AND LUG CLASS 300 LBS

DN (mm)	Size (inch)	Kv / Cv-value relating to the face-to-face dimension			Kv / Cv-value according to EN1267		
		Kva value (m ³ / h) at ΔP=1 bar	Cva value in US gallons / min at ΔP=1 psi	ζ	Kva value (m ³ / h) at ΔP=1 bar	Cva value in US gallons / min at ΔP=1 psi	ζ
50	2"	93	108	1.1	71	82	1.8
65	2 1/2"	91	106	3.1	87	101	2.8
80	3"	141	164	5.0	96	111	2.3
100	4"	350	406	1.1	257	298	2.1
125	5"	446	517	1.7	313	363	3.4
150	6"	1068	1239	0.6	863	1001	1.0
200	8"	1847	2143	0.6	1490	1728	1.0
250	10"	3267	3790	0.6	2706	3139	0.8
300	12"	4915	5701	0.6	4072	4724	0.8
350	14"	5091	5906	0.7	4060	4710	1.1
400	16"	7133	8274	0.7	5767	6690	1.0
450	18"	10020	11623	0.5	8397	9741	0.7
500	20"	13642	15825	0.4	11775	13659	0.6
600	24"	18122	21022	0.5	15249	17689	0.7

Size: DN	50	65	80	100	125	150	200	250	300	350	400	450	500	600	700	750	800	900	1000	1200	
Size: Inches	2"	2 1/2"	3"	4"	5"	6"	8"	10"	12"	14"	16"	18"	20"	24"	28"	30"	32"	36"	40"	48"	
PN 10 / 16 / Class 150 / RTFE																					
Working Pressure	Nm	Nm	Nm	Nm	Nm	Nm	Nm	Nm	Nm	Nm	Nm	Nm	Nm	Nm	Nm	Nm	Nm	Nm	Nm	Nm	Nm
PA 0.0 bar / 0.0 psi	37	37	33	61	72	80	128	233	260	370	405	824	876	1 264	1 537	1 835	1 937	2 160	3 421	3 995	
PA 1.0 bar / 14.5 psi	38	38	35	64	76	86	140	255	291	411	460	908	981	1 435	1 774	2 127	2 272	2 587	4 040	4 896	
PA 2.5 bar / 36.3 psi	39	39	37	68	82	95	158	287	337	472	542	1 033	1 138	1 691	2 129	2 566	2 773	3 228	4 968	6 248	
PA 6.0 bar / 87.0 psi	42	42	41	77	96	117	199	361	443	615	734	1 326	1 506	2 290	2 957	3 590	3 945	4 722	7 134	9 402	
PA 10.0 bar / 145.0 psi	46	46	47	87	112	142	245	446	566	779	954	1 661	1 926	2 974	3 903	4 760	5 283	6 430	9 609	13 007	
PA 16.0 bar / 232.0 psi	52	52	55	103	136	178	315	574	749	1 025	1 284	2 163	2 557	4 000	5 323	6 516	7 291	8 992	13 322	18 415	
PA 20.0 bar / 290.0 psi	55	55	60	113	152	203	362	659	871	1 189	1 504	2 498	2 977	4 684	6 269	7 686	8 629	10 699	15 797	22 020	
PN 25 / 40 / Class 300 / RTFE																					
Working Pressure	Nm	Nm	Nm	Nm	Nm	Nm	Nm	Nm	Nm	Nm	Nm	Nm	Nm	Nm	Nm	Nm	Nm	Nm	Nm	Nm	Nm
PA 0.0 bar / 0.0 psi	37	37	54	73	129	145	247	429	500	744	1 035	1 436	1 572	1 847	3 407	3 637	3 942	5 273	6 538	9 176	
PA 1.0 bar / 14.5 psi	38	38	55	76	133	152	260	453	534	793	1 107	1 529	1 689	2 021	3 703	3 979	4 333	5 844	7 250	10 342	
PA 2.5 bar / 36.3 psi	39	39	57	80	140	162	279	488	585	865	1 214	1 668	1 864	2 281	4 147	4 493	4 921	6 701	8 317	12 091	
PA 6.0 bar / 87.0 psi	42	42	62	89	155	185	324	570	703	1 033	1 465	1 993	2 274	2 889	5 183	5 691	6 292	8 700	10 807	16 172	
PA 10.0 bar / 145.0 psi	46	46	68	100	172	212	375	664	839	1 225	1 752	2 364	2 742	3 583	6 366	7 060	7 860	10 984	13 652	20 836	
PA 16.0 bar / 232.0 psi	52	52	76	115	197	252	452	805	1 042	1 513	2 183	2 921	3 444	4 624	8 142	9 113	10 211	14 411	17 920	27 832	
PA 20.0 bar / 290.0 psi	55	55	82	126	215	279	504	899	1 178	1 705	2 470	3 293	3 912	5 319	9 326	10 482	11 778	16 695	20 766	32 496	
PA 25.0 bar / 362.5 psi	60	60	88	139	236	312	568	1 016	1 348	1 945	2 828	3 757	4 497	6 186	10 805	12 193	13 737	19 551	24 323	38 325	
PA 40.0 bar / 580.0 psi	74	74	109	178	300	413	761	1 368	1 856	2 665	3 905	5 150	6 253	8 790	15 244	17 327	19 614	28 117	34 993	55 815	
PA 50.0 bar / 725.0 psi	83	83	123	204	343	480	889	1 602	2 196	3 145	4 622	6 078	7 423	10 525	18 203	20 750	23 532	33 829	42 107	67 474	

Note: values for metal-seated on request

PRESSURE-TEMPERATURE-DIAGRAM IN COMPLIANCE WITH ISO 7005 & ASME B16.34

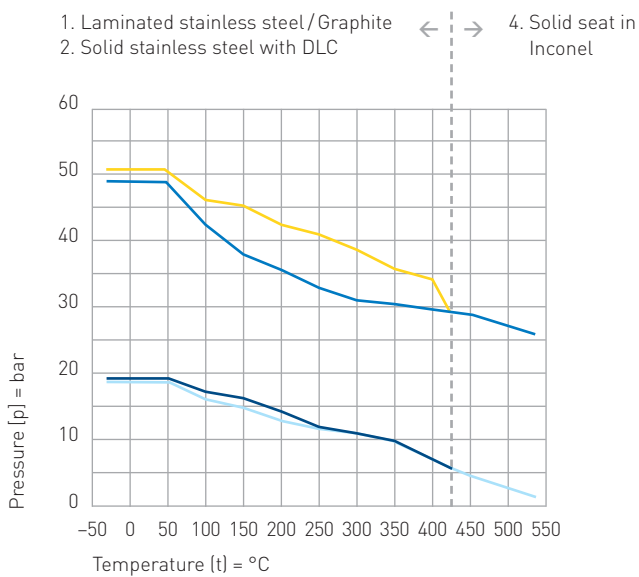

- ANSI Class 150 Carbon steel A216 WCB
- ANSI Class 150 Stainless steel A351 CF8M
- ANSI Class 300 Carbon steel A216 WCB
- ANSI Class 300 Stainless steel A351 CF8M

PRESSURE-TEMPERATURE-DIAGRAM IN COMPLIANCE WITH API 609

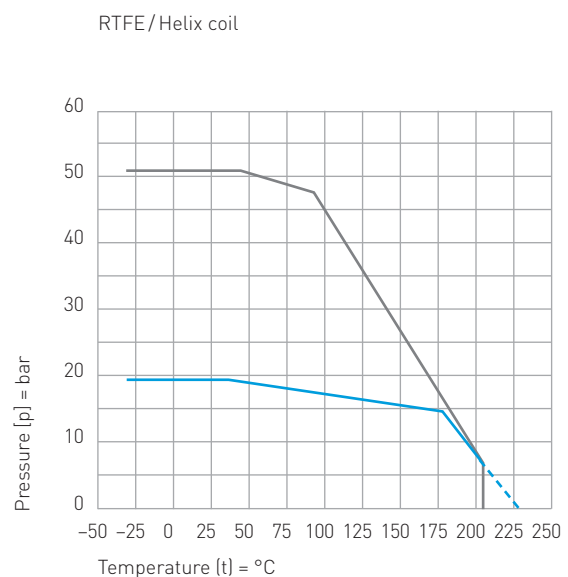

- ANSI Class 150
- ANSI Class 300
- ANSI Class 300

Dynaxe, the new standard for double-eccentric butterfly valves, is a High Performance product line of the Eurovalve® range, which has been developed and produced by the Dutch-based company Wouter Witzel Eurovalve.

Wouter Witzel Eurovalve offers the optimum solution for each specific market segment and application. This has been the core of Wouter Witzel Eurovalve business development over the years and is the basis of the company's high reputation and global expansion. For more information, please visit www.wweurovalve.nl

Wouter Witzel Eurovalve is a member of the AVK Group.

Headquarters & Distribution Centre
Wouter Witzel EuroValve BV
Industrieterrein De Pol 12
7581 CZ Losser
Netherlands
Tel: +31 (0) 53 / 5 3 69-5 36
Fax: +31 (0) 53 / 5 3 69-5 00
E-mail: info@wweurovalve.nl
Web: www.wweurovalve.nl