

Thermostatic Control Valves

Model B

Typical applications

- Lubricating oil temperature control
- Jacket water high temperature (HT)
- Secondary water low temperature (LT)
- Heat recovery
- Water saving applications
- Boiler inlet temperature control
- Co-generation, cooling towers
- Temperature mixing or diverting
- Engine and compressor cooling system



B Valve

Key benefits

- No external power source required - simple, low cost installation
- No user setting needed - 'fit and forget' solution
- Small number of parts - simple maintenance and low cost of ownership
- Robust design capable of high vibration and shock applications
- Easy installation, operates in any mounting position
- Automatic self-sensing control with positive proportional valve action

Accreditations available

- PED Suitable for Group 1 & 2 liquids (Ensure materials are compatible)
- ATEX  11 2 G X
- CE Complies with all relevant EU directives

Key features

- Flow rates of 15 - 400 m³/hr (68 - 1750 US gpm)
- Combinations available: Housings in cast iron, ductile iron, aluminum, bronze, carbon steel, stainless steel
- DN40 - D200 (1½" to 8") pipe sizes
- Threaded and flanged connections
- Tamper-proof temperature settings from 13°C to 116°C (55°F to 240°F)
- Pressure ratings up to 45 bar (655 psi)

amot

www.amot.com

Thermostatic Control Valves - Model B

Contents

Overview	3
Applications	4
Valve detail	
Valve body specification	5
Characteristics	6
Flow coefficient	6
Maximum working pressures	7
Specification	7
Dimensions	8
Weights	9
Element characteristics	9
How to order	10
Recommended spares	11

Thermostatic Control Valves - Model B

Overview

AMOT model B thermostatic valves are available in a wide selection of sizes and settings to fill a multitude of fluid temperature control requirements. These valves may be mounted in any position and use the proven expanding wax principle to actuate the 3-way temperature element assemblies. The model B valves may be used for diverting or mixing service. They make very economical temperature limiting

valves for engine and lubricating oil cooling, and to prevent scalding in home, motel or hotel hot water supply systems. Radiant heating systems can use these valves in limiting water temperature to prevent surface cracking and over-heating of plastic piping. Other applications include electronic and battery cooling circuits, pump temperature relief valves etc.

Available housing materials

- Cast iron
- Aluminum
- Steel
- Ductile iron
- Bronze
- Stainless steel

Seal materials

- Buna-N/Nitrile
- Viton
- Neoprene

Element materials

- A combination of bronze, brass and stainless steel (standard)
- A combination of nickel plated and stainless steel

Leakholes

In some applications, it is necessary to have leak holes drilled in the element to ensure a small flow between ports A and C. Leak holes are available in sizes ranging from 1.6 mm

to 12.7 mm ($\frac{1}{16}$ " to $\frac{1}{2}$ "). Please refer to the Temperature Control Valve Selection Guide to determine the hole size required for specific applications.

Temperature settings

A wide selection of element materials, seals, and temperatures are available. Follow the equipment manufacturers' guidelines for heating/cooling systems.

Temperature settings are available from 13°C to 116°C (55°F to 240°F). Refer to the Temperature & Element Characteristics table on page 6 for specific temperature settings. In general, the temperature quoted is the nominal operating temperature in diverting mode on water systems. For long life, AMOT valves should not be operated continuously at

temperatures in excess of 14°C (25°F) of their maximum continuous rating. If this condition is anticipated then consult AMOT for suitable alternatives.

For mixing and oil circuits the temperature may be one to two degrees higher due to flow, viscosity and other system parameters. Elements and seals are available in a variety of materials. These materials are suitable for most applications. Please refer to the Temperature Control Valve Selection Guide for material compatibility information.

Manual override (BR & BM)

BR type valves are fitted with a manual override (BM type) which allows a progressive opening of port A to C. Manual override is often a requirement for marine applications.

For BM type valves, in automatic mode the valve will control the temperature automatically, but actuating the manual

override mechanism on top of the valve will cause the element to move towards its hot (extended) position, regardless of temperature. Each element assembly has its own Manual Override.

Manual Override should only be used in case of an emergency or element failure.

Thermostatic Control Valves - Model B

Applications

Diverting Applications

When valves are used for diverting service, the inlet is Port A (temperature sensing port), with Port C being connected to the cooler, and Port B connected to the cooler by-pass line.

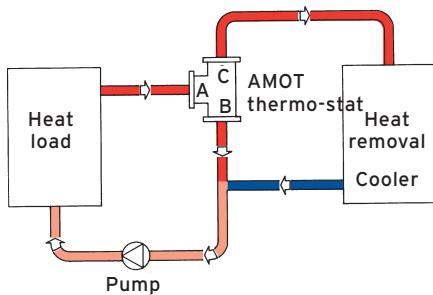

Mixing Applications

When valves are used for mixing service, Port C is the cold fluid inlet port from the cooler, Port B is the hot by-pass fluid inlet, and Port A the common outlet. Port A is the temperature sensing port and will mix the hot and cold fluids in the correct proportion so as to produce the desired outlet temperature leaving Port A.

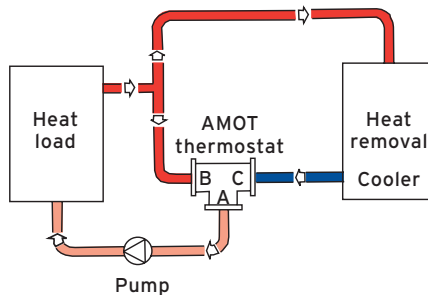

2-way Water Saving Applications

Valve as shown maintains minimum flow through cooler to conserve water. Requires internal leak hole to permit small flow for sensing.

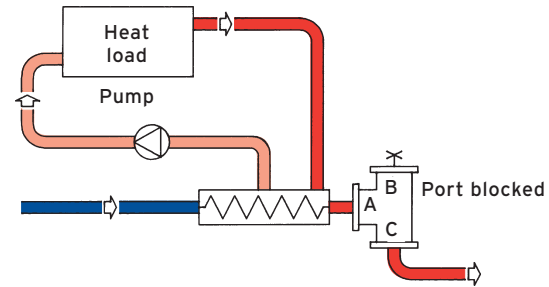

Valve characteristics

Pressure drop (Metric units)

AMOT thermostatic valves are designed to produce minimal pressure drop. The normal recommendation in sizing the valves is to select a pressure drop between 0.14 to 0.5 Bar (2 and 7 PSI).

— Water

AMOT thermostatic valves operate in any position and may be oriented at the convenience of the system designer. In the smaller sizes, the valve may be supported by the connecting pipe but should not be subjected to excessive bending. Line up the piping before tightening the connecting bolts. Larger sizes should not be used to support long and heavy lengths of pipe, nor used to draw up lengths of pipe which have been fabricated too short.

If the valve is mounted at the high point of the system, the system should be properly vented to prevent trapping air at the temperature element assemblies.

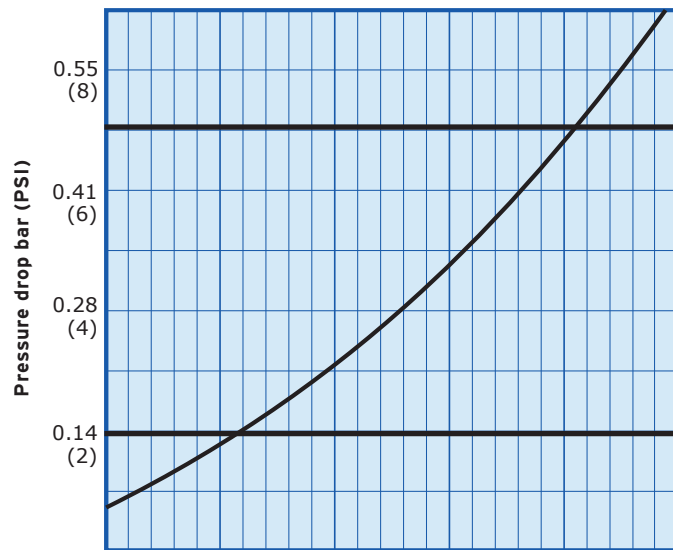

Size	8 (40)	12 (55)	16 (70)	20 (85)	24 (100)	30 (115)
1½	8 (40)	12 (55)	16 (70)	20 (85)	24 (100)	30 (115)
2	10 (40)	15 (60)	20 (80)	25 (100)	30 (120)	35 (140)
2½	19 (75)	28 (110)	37 (145)	46 (180)	55 (215)	64 (250)
3	20 (80)	30 (120)	40 (160)	50 (200)	60 (240)	70 (280)
33	28 (123)	41 (180)	55 (242)	69 (304)	84 (370)	97 (427)
4	40 (160)	60 (264)	80 (320)	100 (400)	120 (480)	140 (560)
5	60 (240)	90 (396)	120 (480)	150 (600)	180 (720)	210 (840)
6	90 (360)	135 (594)	180 (720)	225 (900)	270 (1080)	315 (1260)
8	135 (590)	195 (770)	260 (1030)	320 (1270)	390 (1540)	450 (1840)

Flowrate m³/hr (US gpm) - Water

Thermostatic Control Valves - Model B

Valve characteristics

Flow coefficient

AMOT valve flow coefficient (calculated)		
Size	Kv	Cv
1 ¹ / ₂ B	36	42
2B	44	51
2 ¹ / ₂ B	79	81
3B	87	101
33B	121	140
4B	176	203
5B	263	304
6B	394	456
8B	571	660

Kv is the flow coefficient in metric units. It is defined as the flow rate in cubic meters per hour (m³/h) of water at a temperature of 16° celsius with a pressure drop across the valve of 1 bar. Cv is the imperial coefficient. It is defined as the flow rate in US Gallons per minute [gpm] of water at a temperature of 60° fahrenheit with a pressure drop across the valve of 1 psi. (Kv = 0.865 Cv / Cv = 1.156 Kv)

The basic formula to determine the Kv of a valve is:

$$Kv = Q \sqrt{\frac{SG}{Dp}}$$

Q = Flow (m³/h)
Dp = Pressure drop (bar)
SG = Specific gravity of fluid
Kv = Valve flow coefficient

The basic formula to determine the Cv of a valve is:

$$Cv = Q \sqrt{\frac{SG}{Dp}}$$

Q = Flow (US gallons/min)
Dp = Pressure drop (psi)
SG = Specific gravity of fluid
Cv = Valve flow coefficient

There are two other ways that this formula can be used to find the flow in m³/h or pressure drop of a valve in bar:

$$Q = Kv \sqrt{\frac{Dp}{SG}}$$

$$Dp = \left[\frac{Q}{Kv} \right]^2 SG$$

There are two other ways that this formula can be used to find the flow in US gallons/minute or pressure drop of a valve in PSI:

$$Q = Cv \sqrt{\frac{Dp}{SG}}$$

$$Dp = \left[\frac{Q}{Cv} \right]^2 SG$$

Thermostatic Control Valves - Model B

Valve body specification

Material	Nominal bore size inches	Flange standard & class											K - Flanged (600 lb)	
		A - Flanged PN6	B - Flanged PN10	C - Flanged PN16	D - Flanged BS:10	E - Flanged BS:10	F - Flanged ANSI 125 lb	J - Flanged ANSI 150 lb	H - Flanged ANSI 300 lb	L - Flanged JIS 10k	P - Flanged JIS 5k	T - Threaded NPT		U - Threaded BSP (PL)
C- Cast iron	1 1/2 (DN40)													
	2 (DN50)											2B0 and 2BH only		
	2 1/2 (DN65)													
	3 (DN80)													
	33 (DN80)	Cast iron and ductile iron only								Cast iron and ductile iron only				
	4 (DN100)													
	5 (DN125)													
	6 (DN150)													
D- Ductile iron	8 (DN200)													
	1 1/2 (DN40)													
	2 (DN50)													
	2 1/2 (DN65)													
	3 (DN80)													
	33 (DN80)													
	4 (DN100)													
	5 (DN125)													
B- Bronze	6 (DN150)													
	8 (DN200)													
	1 1/2 (DN40)													
	2 (DN50)													
	2 1/2 (DN65)													
	3 (DN80)													
	33 (DN80)													
	4 (DN100)													
S- Steel and R- Stainless Steel	5 (DN125)													
	6 (DN150)													
	8 (DN200)													
	1 1/2 (DN40)													
	2 (DN50)													
	2 1/2 (DN65)													
	3 (DN80)													
	33 (DN80)													
A- Aluminum	4 (DN100)													
	5 (DN125)													
	6 (DN150)													
	8 (DN200)													

 Non standard - please contact AMOT for details



Thermostatic Control Valves - Model B

Maximum working pressures

Measurements in bar (PSI)

Material	1 ^{1/2} B	2B	2BH	2 ^{1/2} B	3B	33B	4B	5B	6B	8B
Bronze	10 (150)	10 (150)	-	10 (150)	10 (150)	-	10 (150)	10 (150)	10 (150)	10 (150)
Cast iron	10 (150)	10 (150)	22 (320)	10 (150)	10 (150)	6 (87)	10 (150)	10 (150)	10 (150)	10 (150)
Ductile iron	n/a	16 (230)	-	16 (230)	16 (230)	-	16 (230)	10 (150)	10 (150)	10 (150)
Stainless steel	n/a	45 (655)	-	45 (655)	45 (655)	-	20 (290)	-	-	n/a
Steel	n/a	45 (655)	-	45 (655)	45 (655)	-	20 (290)	-	-	n/a
Aluminum	n/a	10 (150)	-	10 (150)	10 (150)	-	10 (150)	10 (150)	10 (150)	n/a

Specification

Flow rate	15 – 400m ³ /hr	68 - 1750 US gpm
Body materials	Aluminum (BS: 1490 LM25TF)	For light weight
	Bronze	For seawater, shock resistance and low magnetic permeability
	Cast iron	For fresh water and lubricating oils
	Ductile iron	High performance iron
	Steel	For high strength/pressure ratings
	Stainless steel	Corrosive and special applications
Seal materials	BUNA N, Viton and Neoprene	
Mounting position	Any orientation	
Ports	Below nominal temperature	Ports A and B connected
	Above nominal temperature	Ports A and C connected
Port connections	Screwed	40 and 50 mm (1 ^{1/2} " and 2") BSP.PL or NPT
	Flanged	50 to 200 mm (2" to 8") to most DIN, ANSI, JIS and other standards
Valve sizes (nominal bore)	40, 50, 65, 80, 100, 125, 150 and 200 mm	(1 ^{1/2} ", 2", 2 ^{1/2} ", 3", 4", 5", 6" and 8")
Control temperatures	See element characteristics table on page 9	
Accreditations available	PED	40 to 150 mm (1 ^{1/2} " to 6") inclusive suitable for Group 1 & Group 2 liquids. 200 mm (8") suitable for Group 2 liquids only. (Ensure materials are compatible).
	ATEX	 II 2 G X
		Complies with all relevant EU directives

Thermostatic Control Valves - Model B

Valve dimensions

1½ and 2BO/BH/BG 2BF

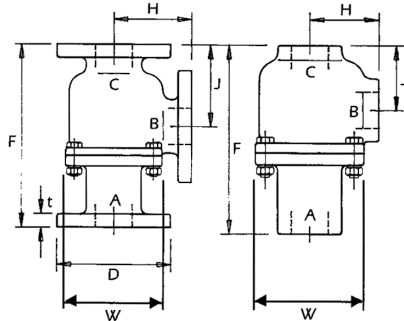

2BC, 2BM and 2½ – 6BO/BR

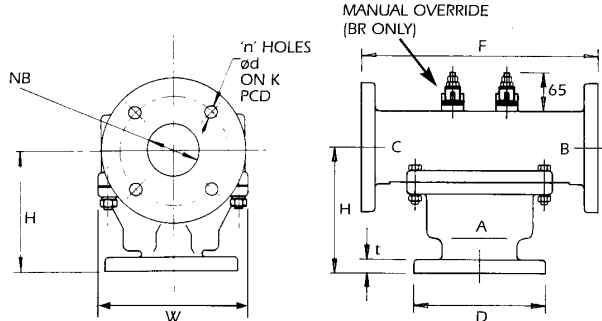

8BO, BR

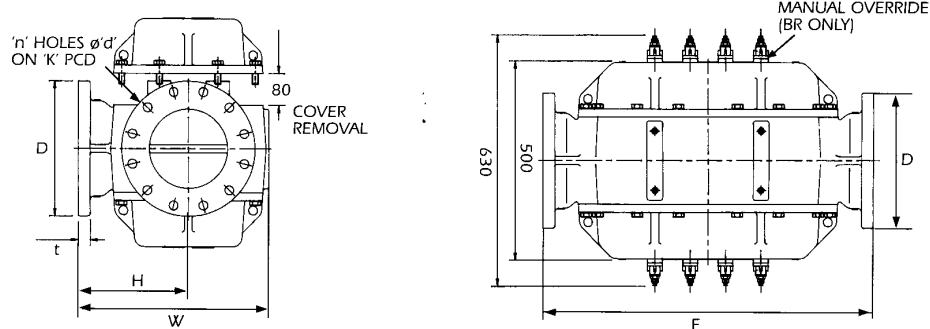

Dimension/ Connection mm (inches)		1½ BO	1½ BH	2BO/ BH/BG	2BF	2BC/BR	2½/2BO/ BR	3BO/BR	33BO/ BR	4BO/BR	5BO/BR	6BO/BR	8BO/BR
Conn. Code	Nom. Bore	40 (1½)	40 (1½)	50 (2)	50 (2)	50 (2)	65 (2½)	80 (3)	80 (3)	100 (4)	125 (5)	150 (6)	200 (8)
F		246 (9.685)		246 (9.685)	270 (10.630)	225 (8.858)	254 (10.000)	267 (10.512)	267 (10.512)	403 (15.866)	489 (19.252)	489 (19.252)	840 (33.071)
H		91 (3.583)		91 (3.583)	113 (4.449)	149 (5.866)	165 (6.496)	171 (6.732)	171 (6.732)	217 (8.543)	241 (9.488)	254 (10.000)	280 (11.024)
J		97 (3.819)		97 (3.819)	121 (4.764)	-	-	-	-	-	-	-	-
D		-		-	165 (6.496)	165 (6.496)	185 (7.283)	200 (7.874)	200 (7.874)	224 (8.819)	254 (10.000)	285 (11.220)	340 (13.386)
W		140 (5.512)		139 (5.472)	139 (5.472)	140 (5.5120)	210 (8.268)	210 (8.268)	245 (9.646)	308 (12.126)	349 (13.740)	483 (19.016)	485 (19.094)
t		-		-	20 (0.787)	20 (0.787)	20 (0.787)	22 (0.866)	22 (0.866)	24 (0.945)	26 (1.024)	26 (1.024)	30 (1.181)
K	PN10/ 16	-		-	125 (4.921)	125 (4.921)	145 (5.709)	160 (6.299)	160 (6.299)	180 (7.087)	210 (8.268)	240 (9.449)	295 (11.614)
	125/ 150LB	-		-	120.6 (4.748)	120.6 (4.748)	139.7 (5.500)	154.6 (6.008)	152.6 (6.008)	190.5 (7.5)	216 (8.504)	240 (9.449)	299 (11.772)
d	PN10/ 16	-		-	18 (0.709)	18 (0.709)	18 (0.709)	18 (0.709)	18 (0.709)	18 (0.709)	18 (0.709)	23 (0.906)	23 (0.866)
	125/ 150LB	-		-	19 (0.748)	19 (0.748)	19 (0.748)	19 (0.748)	19 (0.748)	19 (0.748)	22.2 (0.874)	23 (0.906)	22 (0.866)
n	PN10/ 16	-		-	4 (0.157)	4 (0.157)	4 (0.157)	8 (0.315)	8 (0.315)	8 (0.315)	8 (0.315)	8 (0.315)	8 (0.315) or 12 (0.472)*
	125/ 150LB	-		-	4 (0.157)	4 (0.157)	4 (0.157)	4 (0.157)	4 (0.157)	8 (0.315)	8 (0.315)	8 (0.315)	8 (0.315)

* 8 holes on ND10 flange, 12 holes on ND16 flange

Thermostatic Control Valves - Model B

Weights

Weights in kg (lbs)

Material	1 ¹ / ₂ BO	1 ¹ / ₂ BM	2BO, BH,BG	2BF	2BC, BM, BR	2 ¹ / ₂ BO, BR	3BO,BR	33BO, BR	4BO,BR	5BO,BR	6BO,BR	8BO,BR
Bronze	13 (29)	12 (25)	13 (29)	22 (49)	26 (57)	29 (64)	36 (79)	42 (93)	68 (150)	109 (240)	136 (300)	315 (694)
Cast/ductile iron	11 (24)	-	11 (24)	18 (40)	18 (40)	24 (53)	27 (60)	35 (77)	61 (134)	91 (201)	123 (271)	285 (628)
Stainless steel/steel	-	-	-	-	20 (44)	34 (75)	36 (79)	-	-	-	-	-
Aluminum	-	-	-	7 (15)	-	10 (22)	11 (24)	14 (31)	24 (53)	35 (77)	48 (106)	-

Element characteristics

Control temperature

Code	Control temp.		Rated range				Max temp continuous	
			Crack open		Full open			
	°C	°F	°C	°F	°C	°F	°C	°F
55	13	55	8	47	20	68	35	95
57	14	57	10	50	18	65	30	86
75	24	75	20	68	30	86	38	100
90	32	90	27	81	35	95	43	110
95	35	95	29	85	41	105	49	120
100	38	100	34	93	42	108	50	122
105	41	105	35	95	45	113	55	131
110	43	110	38	100	47	117	56	133
115	46	115	40	104	50	122	61	142
120	49	120	43	110	54	130	66	150
130	54	130	51	124	60	140	68	155
135	57	135	54	129	63	145	71	160
140	60	140	57	135	66	151	74	165
145	63	145	60	140	69	156	79	174
150	66	150	63	145	72	161	82	180
155	68	155	66	150	74	165	85	185
160	71	160	68	155	78	173	88	190
165	74	165	71	160	80	175	88	190
170	77	170	74	165	83	181	93	200
175	79	175	77	170	85	185	102	215
180	82	180	79	175	88	191	104	220
185	85	185	82	180	91	196	106	223
195	91	195	87	188	98	209	107	225
205	96	205	93	200	102	215	108	226
215	102	215	98	209	107	225	115	239
225	107	225	102	216	113	236	118	244
230	110	230	104	219	115	239	118	244
240	116	240	108	227	122	252	123	253.5

Element and valve seal material

Code	Element and valve seal material
01	1096X standard with Nitrile seals
02	1096P plated with Viton seals
03	1096X with Viton seals
05	6836S saltwater with Nitrile seals
07	2433X manual override with Nitrile seals
09	69385 saltwater manual override with Nitrile seals
11	5566X reduced stroke with Nitrile seals
12	5566P reduced stroke plated with Viton seals
20	5566X reduce stroke with Viton seals
44	1096X with Neoprene seals
45	1096P with Neoprene seals
53	2433X with Viton seals

Thermostatic Control Valves - Model B

How to order

Use the tables below to select the unique specification of your B Valve.

Example code	3	BO	C	F	145	01	- D	0	-AA	Code Description
Valve Size	1 1/2									Nominal Bore Size 1 1/2 inch (DN50)
	2									2 inch (DN50)
	2 1/2									2 1/2 inch (DN65)
	3									3 inch (DN80)
	33									3 inch (DN80)
	4									4 inch (DN100)
	5									5 inch (DN125)
	6									6 inch (DN150)
8									8 inch (DN200)	
Valve model & revision										Model & Revision Level
		BO								1 1/2" and 2" screwed connections
		BO								2 1/2" and 8" flanged
		BC								Flanged 'T' configuration (1 1/2" and 2")
		BF								Flanged 'F' configuration (2" only)
		BH								Screwed high pressure (1 1/2" (available from US only) and 2" only)
		BM								Manual override (available from USA only)
	BR								Manual override (2" to 8")	
Body material										Body Material
		A								Aluminum (not 8 and 33)
		C								Cast Iron*
		S								Steel (2", 2 1/2", 3" and 4" only)
		B								Bronze (not 33)
		D								Ductile iron
		R								Stainless steel (2", 2 1/2", 3" and 4" only)
Port connection										Port Connection
		A								Flanged PN6
		B								Flanged PN10
		C								Flanged PN16
		D								Flanged BS:10
		E								Flanged BS:10
		F								Flanged ANSI 125 lb (cast iron, bronze and ductile only)
		J								Flanged ANSI 150 lb (steel and stainless steel only)
		H								Flanged ANSI 300 lb (steel and stainless steel only)
		L								Flanged JIS 10k
		P								Flanged JIS 5k
		T								Threaded NPT (1 1/2" and 2BO and 2BH only)
	U								Threaded BSP (PL) (1 1/2" and 2BO and 2BH only)	
Control temperature										Control temperature °F (°C)
						55				See Control Temperature table on page 9
Element type										Element
						01				See Element and Valve Seal Material table on page 9
Leakhole sizes inches (mm)										Leakhole size inches (mm)
							0			None
							A			1/2" (13)
							B			1/4" (6.5)
							C			3/8" (9.5)
							D			1/8" (3.2)
							E			1/16" (1.6)
							F			3/32" (2.4)
						G			3/16" (5)	
						H			5/16" (8)	
Leakhole quantity										Leakhole quantity (no. of elements with leak hole, maximum 1 per element)
										Refer to nominal bore size above for maximum number of leakholes per valve size (1 per element)
Customer special requirements										Customer special option codes
									-AA	Standard product
									-***	Customer special code assigned

* AMOT reserves the right to substitute a ductile iron product in place of cast iron to meet customer delivery requirements.

Thermostatic Control Valves - Model B

Recommended Spares

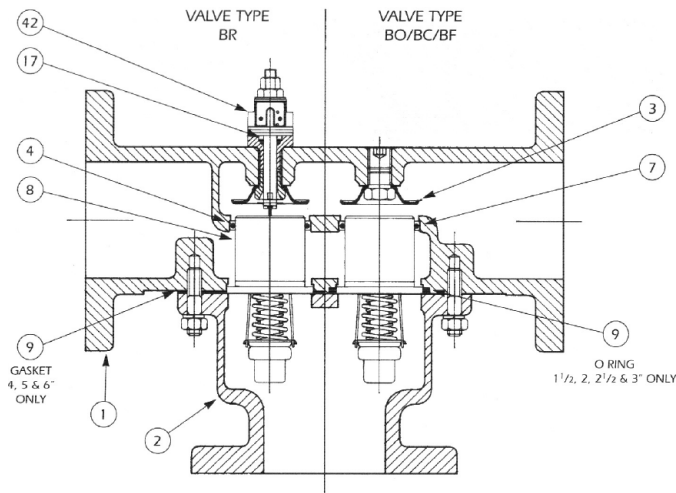

It is recommended that all the spares listed below are replaced each time the valve is disassembled.

Service Kits

Spare kits are available; these include all seals and gaskets required to service the unit. Kits only include item numbers 7, 9 and 17.

Note: Kits do not include seats or sleeves (items 3 and 4) - for these, refer to Replacement Wear Parts table, noting one of each is required per element position.

Manual operator components are not available individually, but a service kit is available. The kit can also be used to convert valve type BO to BR. Please contact AMOT for details.

How to order

Example	46342X	15	3	Code description
Valve		15		1 1/2"
		20		2"
		25		2 1/2"
		30		3"
		33		3" 3 element
		40		4" all body materials except steel & stainless steel
		41		4" steel & stainless steel bodies only
		50		5"
		60		6"
		80		8"
Valve Type/Seal Material			1	BO/Nitrile
			2	BO/Viton
			3	BO/Neoprene
			4	BR/Nitrile
			5	BR/Viton
			6	BR/Neoprene

Sample code for 1 1/2" BOCT10001-00-AA

46342X 15 1

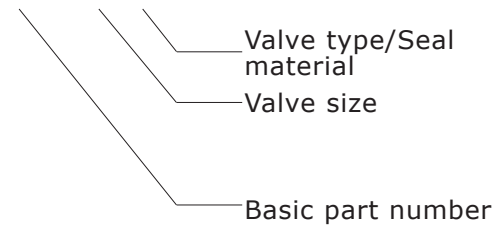

Thermostatic Control Valves - Model B

Replacement Wear Parts

Item	Description	Freshwater/Lub oil	Salt water
3	Seat BO, BF (US versions only)	9585L001	9585L001
3	Seat BO, BF (UK versions only) and BM, BR	9585L002	9585L002
4	Sleeve	1182	1182P
5	Cap screw BO, BC, BF, BH	11132L062	11132L062
5	Bushing BM only)	9649L002	9649L002
6	Lockwasher BO, BC, BF, BH	11133	11133
40	Flat washer (BO, BC, BF, BH)	11226L002	11226L001

Number of Elements in different units

Size code	Valve nominal bore		Number of elements
	Inches	mm	
1 1/2	1.5	40	1
2	2	50	1
2 1/2	2.5	65	2
3	3	80	2
33	3	80	3
4	4	100	4
5	5	125	6
6	6	150	9
8	8	200	16

User Maintenance Parts

Part number	Description	Quantity
1096X (temp °F)	Element assembly	See 'Number of elements' table
6836S (temp °F)	Element assembly, 'saltwater' plated	See 'Number of elements' table
2433X (temp °F)	Element assembly with manual override	See 'Number of elements' table
6838S (temp °F)	Element assembly, 'saltwater' plated, with manual override	See 'Number of elements' table

Americas

AMOT USA
8824 Fallbrook Dr
Houston, TX 77064
USA

Tel +1 (281) 940 1800
Fax +1 (713) 559 9419
Email general: sales@amotusa.com
orders: orders@amotusa.com
customer service: cs@amotusa.com

Asia and Australasia

AMOT Shanghai
Unit 4102-4104, United Plaza
1468 NanJing Road West
Shanghai 200040
China

Tel +86 (0) 21 6279 7700
Fax +86 (0) 21 5237 8560
Email shanghai@amot.com

AMOT Singapore
10 Eunos Road 8 #12-06
Singapore Post Centre
Singapore 408600

Tel +65 6408 6265
Fax +65 6293 3307
Email singapore@amot.com

Europe, Middle East and Africa

AMOT
Western Way
Bury St Edmunds
Suffolk, IP33 3SZ
United Kingdom

Tel +44 (0) 1284 762222
Fax +44 (0) 1284 760256
Email info@amot.com

AMOT Controls GmbH
Rondenbarg 25
22525 Hamburg
Germany

Tel +49 (0) 40 8537 1298
Fax +49 (0) 40 8537 1331
Email germany@amot.com

AMOT Russia
#34 Shabolovka Street
Building 2
Moscow 115419
Russia

Tel +7 495 617 12 93
Fax +7 495 913 97 65
Email russia@amot.com