

Cat.no.:E-PS

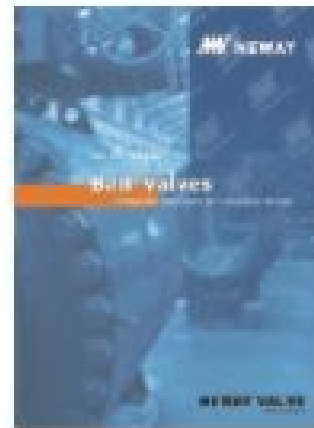

Cat.no.:E-BV

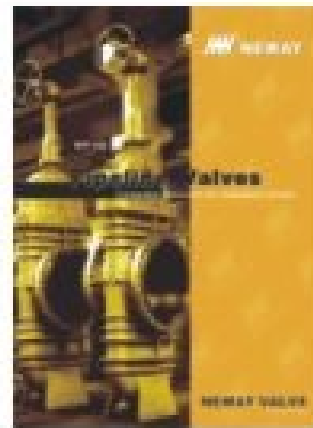

Cat.no.:E-PLV



Cat.no.:E-BFV

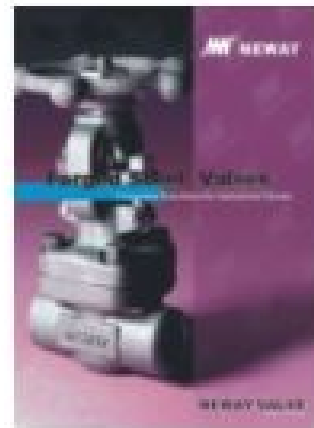

Cat.no.:E-FSV



Cat.no.:E-MV

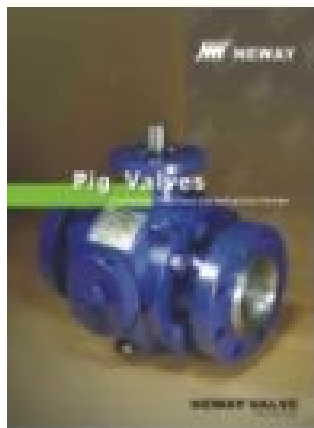

Cat.no.:E-PV



Cat.no.:E-AV



Cat.no.:E-BAGV

NW NEWAY
NEWAY VALVE (SUZHOU) CO., LTD.

No.999 Xiangjiang Road, Suzhou New District,P.R. China
Post Code:215129
Tel: 86-512-666-51365
Fax: 86-512-666-51360
E-Mail: neway@neway.com.cn
<http://www.newayvalve.com>

Distributed by:

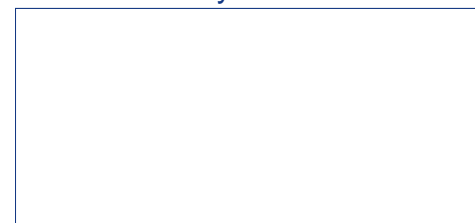

Cat.no.:E-GGC-2007

NW NEWAY

API 600 ASME B16.34

Gate, Globe & Check Valves

Complete Solutions for Engineered Valves

NEWAY VALVE

Cat.no.:E-GGC-2007

Table of Contents

- Introduction**
- 1 Quality Commitment
- 2 Product range
- 3 Technical Innovation
- 4 Introduction of Foundries
- 5 Advanced Manufacturing
- 6 Quality Control
- 7 Typical Product View
- 8-9 How to Order
- Gate Valve**
- 11 Design Feature
- 12 Material List
- 13-15 Dimension & Weight
- Globe Valve**
- 16 Design Feature
- 17 Material List
- 18-20 Dimension & Weight
- Check Valve**
- 21 Design Feature
- 22 Material List
- 23-25 Dimension & Weight
- Pressure Seal Valve**
- 26 **High Alloy Casting**
- Pressure Seal Gate Valve**
- 28 Design Feature
- 29 Material List
- 30-31 Dimension & Weight
- Pressure Seal Globe Valve**
- 32 Design Feature
- 33 Material List
- 34-35 Dimension & Weight
- Pressure Seal Check Valve**
- 36 Design Feature
- 37 Material List
- 38-39 Dimension & Weight
- 40-45 **Torque & Thrust**
- 46 **Gear Operator**
- 47 **Low Fugitive Emission Control**
- 48-50 **NACE Introduction Special Design Feature**



Complete Solutions for Engineered Valves

Being one of the leading valve manufacturer in the world, Neway specializes in the development of innovative designs, through intensive R&D programs and engineering excellence. We engineer and manufacture valve solutions for all industries.

Main product lines include Gate, Globe, Check, Butterfly and Ball valves. Neway's quality and innovative designs are recognized by many global users and EPC's. These products have been installed throughout the world, handling a wide variety of applications in the Gas, Oil, Refining, Chemical, Marine, Power Generation and Pipeline Transmission Industries.

Neway Facilities

Neway has developed and implemented a group management system based on multi-plant manufacturing. Valves are manufactured in 6 specialized production facilities, four in China, and one each in Mexico & Saudi Arabia. Castings are sourced from Neway-owned specialized foundries. Of the company employs over 1700 people.

The company operates an intranet consisting of over 400 computers, running the most advanced R&D software including CAD, I-Deas, Pro-E, a number of CNC & machine centers and warehouse bar code management systems. We are one of the few manufacturers performing ERP manufacture management, in-house fire safe tests, cryogenic tests, high pressure gas tests and fugitive emission test.

Quality Assurance

Neway's quality assurance is dedicated to the pursuit of zero defect valves to customers. We perform active 6 sigma quality management to continually enhance process control management based on advanced data statistical analysis. Neway holds many industrial certificates, including ISO 9001, CE/PED, TA-Luft, API 6A, API 6D, ABS, and Fire Safe approvals.

ISO 9001

API 6D

API 6A

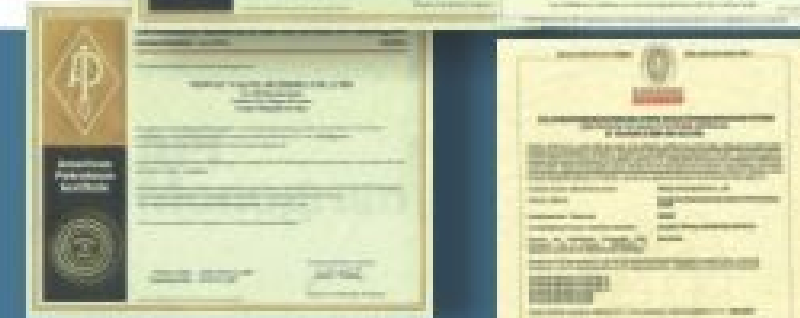

TA Luft



CE/PED



ABS



API 591



Fire Safe Test

Neway recognizes the importance of valve quality for the safety and protection of personnel health and property. It is our quality commitment to focus our resources to provide our customer's with first class products at a competitive price, that are designed, manufactured, inspected and tested in accordance with our customer's specifications and that comply with all international standards.

With respect to the facts that the current industrial standards do not always take into consideration the likelihood and consequences of possible deterioration in service, related to specific service fluids or the external environment in which they operate. Our customers are requested to keep an open line of communication with our engineering department to identify and implement standards, that will provide valves with the possibility of deterioration in service, so as to ensure safety over the valves expected lifetime.

Neway Cast Carbon Steel Gate ,Globe & Check Valves.

Valve Size		2"	2.5"	3"	4"	5"	6"	8"	10"	12"	14"	16"	18"	20"	24"	26"	28"	30"	32"	36"	40"	42"	48"	52"	54"	56"	60"	64"			
API 600 & B16.34 Bolted Bonnet Valve	Gate Valve	150																													
		300																													
		600																													
		900																													
		1500																													
		2500																													
	Globe Valve	150																													
		300																													
		600																													
		900																													
		1500																													
		2500																													
	Check Valve	150																													
		300																													
		600																													
		900																													
		1500																													
		2500																													
API 600 & B16.34 Pressure Seal Valve	Gate Valve	600																													
		900																													
		1500																													
		2500																													
	Globe Valve	600																													
		900																													
		1500																													
		2500																													
	Check Valve	600																													
		900																													
		1500																													
		2500																													

Note:

1. Face to face and end to end dimension conform to BS 2080,ANSI B16.10 or ISO 5752,
2. End flange dimension conform to ANSI B16.5 for 24 " and below, and ANSI B16.47 for 26 " and above size,
3. BW end dimension conform to ANSI B16.25,
4. Inspection and test in accordance with API 598 or BS EN 12266,
5. Larger than 64 " Valves are available upon Neway standard.

Technical innovation is the engine of Neway continuous growth. Neway is proud to have a young and creative engineering team, they are capable of utilizing the most advanced scientific technology to research and develop products in accordance with market demands. Neway established 3 valve engineering teams: New Product Reach & Development team, Product Design team and Process Technology team.

All Neway engineering teams insist the philosophy of developing a nature quality, safety and cost-efficient valve. We introduced the most advanced computer workbench for improving the existing products and developing new product lines, which include the advanced finite element analysis to virtually verify the new design prior to production; this has resulted in dramatically reducing the new line design time and ensuring a safety and cost efficient final product.

Neway closely cooperates with science and research institutes and universities and has developed valve specific software packages. In the field of valve 3D structure- and finite element analysis Neway leads the way international.



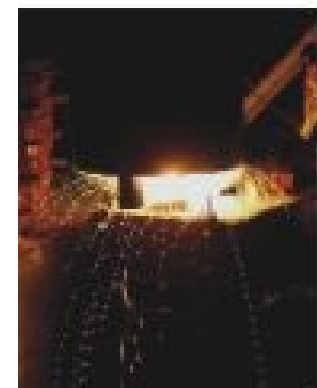

As one of pressure-contained equipments in process control pipeline, valve casting's quality is most important for valve life, personnel and environment safety, especially for the high temperature and high pressure fields. So castings are always certified firstly by the strict customer before valve manufacturer are pre-qualified and approved as a qualify supplier.

Comparing with most of other manufacturers, Neway owned two self foundries: one is mainly to produce big size sand castings by organic ester water glass sand cast process, and other is mainly to produce small size investment castings by loss wax investment cast process. Each foundry is equipped with all kinds of quality inspection facilities, such as: spectrum instrument, non-destructive test equipment, mechanical properties test equipments and so on, therefore Neway is the valve company that can guarantee the whole process of valve manufacturing to ensure the final products quality, delivery, and competitive price, and in return, this enables Neway become a creditable supplier for every customer.

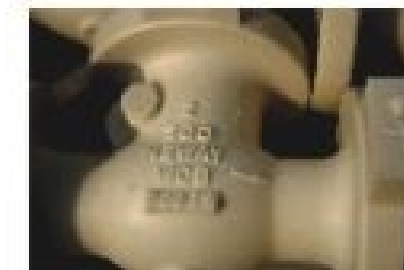
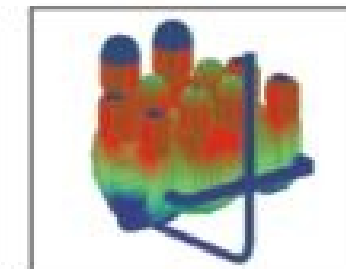
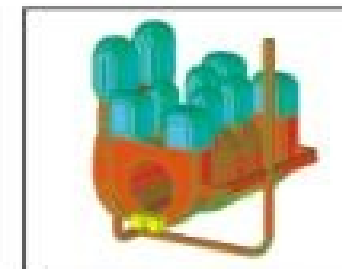

Supply Range & capacity :

Plant Name	Dafeng Foundry	Suzhou Foundry
Process Technology	Lost wax investment casting	Organic ester water glass sand casting
Size Range(in)	1/2" ~10"	2" ~64"
Pressure Rating	ANSI Class 150~600	ANSI Class 150~2500
Weight(Kg)	1~150	100~11000
Material	WCB, WCC, LCB, LCC, WC6, WC9, C5, C12, C12A, CF8, CF8M, CF3, CF3M, CN7M, Monel, Inconel, Duplex Steel, 4A	
Monthly Capacity(Ton)	600	750
Quality Certificate	ISO9001, CE/PED, ADW0	

As a modern manufacturer, NEWAY actively introduced a great deal of advanced modern manufacturing technologies and equipments, which contain the latest computerized manufacturing technology. These include a large number of numeric control machines (Machining center, CNC horizontal and vertical lathe, CNC drilling machine), ERP manufacturing management system, warehouse management system (WMS), bar code system, RFID-Radio Frequency Identify technology and SSW-Stereoscopic Storage Warehouse, which significantly improve our machining quality, process control level and logistic efficiency.

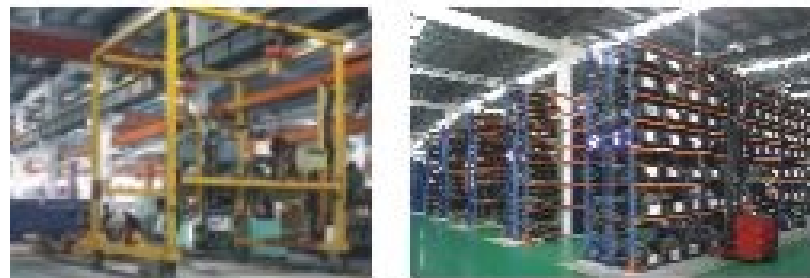

NEWAY also employed a number of conventional lathes with capacity up to machine 64" gate valves, and highly efficient automatic submerged arc welding machine with double arms enabling NEWAY producing up to 60" fully welding ball valves.

The aforementioned assure NEWAY manufacturing philosophy of supplying stable quality product and just in-time delivery services.

NEWAY developed an extensive and advanced inspection and test facilities to control the quality from rough castings or forgings to finished products. These facilities enable us to do in-house Radio Graphic test, Dye-penetrant test, Magnetic test, Positive Material Identifier (PMI), Impact test, Vacuum test, Low Fugitive Emission test, High Pressure Gas test, High Temperature test, Ultrasonic test and Hydro Static test.

NEWAY quality assurance is dedicated in the pursuit of a zero defect valve to customers. NEWAY perform active 6sigma quality management to continually enhance the capacity of process control management based on advanced data statistical analysis. And NEWAY is certified by major international industrial quality standard, including ISO 9001 (certificate under DNV), API 6A (registered no.6A-0716), API 6D (registered no.6D-0285), and our offshore platform valves are type approved by ABS. Moreover, NEWAY is the first valve manufacturer in China to be certified by CE/PED (category IV, mode B+D, certificate under B.V.), all of NEWAY soft seated ball valve are fire safe type tested and certified by Lloyd's Register.

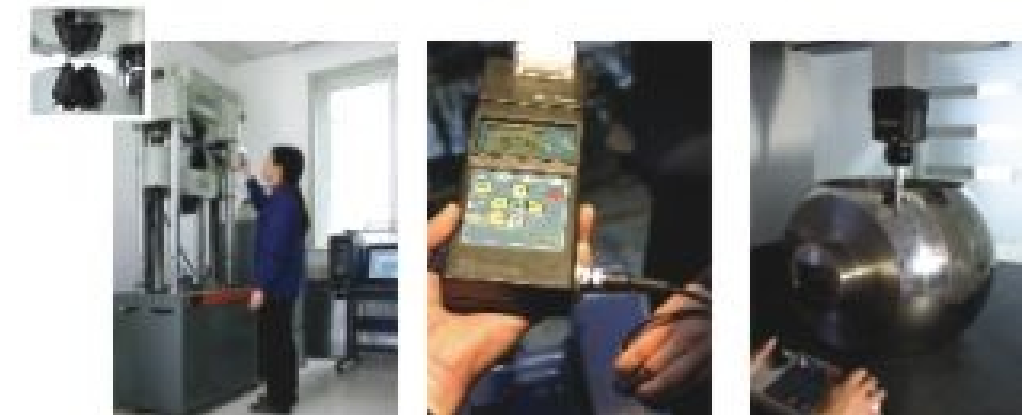

Typical Product View

Typical Product View

1



2



3



4



- 1 20" 300lb Gate Valve
- 2 42" 600lb Gate Valve
- 3 52" 150lb Gate Valve
- 4 18" 600lb Cryogenic Gate Valve
- 5 32" Motor Actuated Gate Valve
- 6 24" 300lb Pneumatic Actuated Gate Valve
- 7 24" 600lb Gate Valve
- 8 16" 900lb Pressure Seal Gate Valve
- 9 42" 150lb Check Valve
- 10 A217 Gr. C12A Gate Valve

10



5



6



7



8



9

Example:

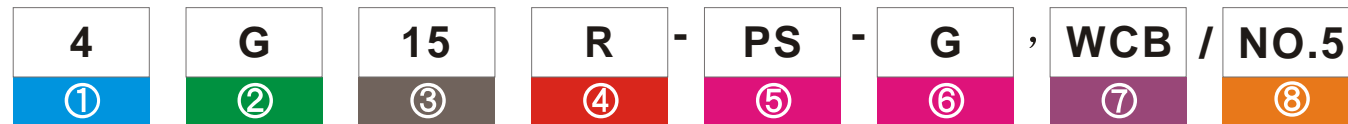

Neway figure numbers are designed to cover essential features. When ordering, please show figure numbers to avoid misunderstanding of your requirements. However a detailed description must accompany any special orders.

Following descriptions provide a basic guideline in valve specification:

① Valve Size

② Valve Type

Valve Type	Gate Valve	Globe Valve	Swing Check
Symbol	G	GL	S

③ ANSI Class

Code	1	3	6	9	15	25
Class (LB)	150	300	600	900	1500	2500

④ End Connection

Symbol	End	Symbol	End
R	Raised face flanged end	S	Socket welding end
J	RTJ flanged end	N	Screwed end
B	Butt-welding end	F	Flat face flange end
W	Wafer		

⑤ ⑥ Actuator and Special Code

Symbol	Description	Symbol	Description
G	Handwheel Operator	SC	Stop check
M	Gear Operator	AN	Angel type globe
P	Electric Actuator	R	Reduce bore
NRS	Pneumatic actuator	GL	Seat and Stem Injection
PS	Non rising stem	ASC	Angle type stop check
	Pressure seal	BP	By Pass

⑦ Shell Material

Material	WCB	LCB	LCC	WC6	WC9	C5	CF8	CF8M	CF3	CF3M	CD4MCuN
ASTM Ref	A216 Gr. WCB	A352 Gr. LCB	A352 Gr. LCC	A217 Gr. WC6	A217 Gr. WC9	A217 Gr. C5	A351 Gr. CF8	A351 Gr. CF8M	A351 Gr. CF3	A351 Gr. CF3M	A995 Gr. CD4MCuN

⑧ Trim Material

API600 Trim Number	Symbol	Disc Surface	Seat Surface	Stem Material
1	1	13%Cr	13%Cr	ASTM A182 Grade F6a
2	2	18%Cr,8%Ni	18%Cr,8%Ni	ASTM A182 Grade F304
5	5	Stellite	Stellite	ASTM A182 Grade F6a
8	8	13%Cr	Stellite	ASTM A182 Grade F6a
9	9	Monel	Monel	Ni Cu Alloy Monel
10	10	18%Cr,8%Ni	18%Cr,8%Ni	ASTM A182 Grade F316
12	12	18%Cr,8%Ni	Stellite	ASTM A182 Grade F316
13	13	Alloy 20 19%Cr,29%Ni	Alloy 20 19%Cr,29%Ni	ASTM B473
	16	Stellite	Stellite	ASTM A182 Grade F316
	20	Bronze	Bronze	Bronze

Note: 1.Trim number 1 to 13 are same as table 13 in API 600 .
2.Trim number 1 may be replaced by trim number 8 without notice.

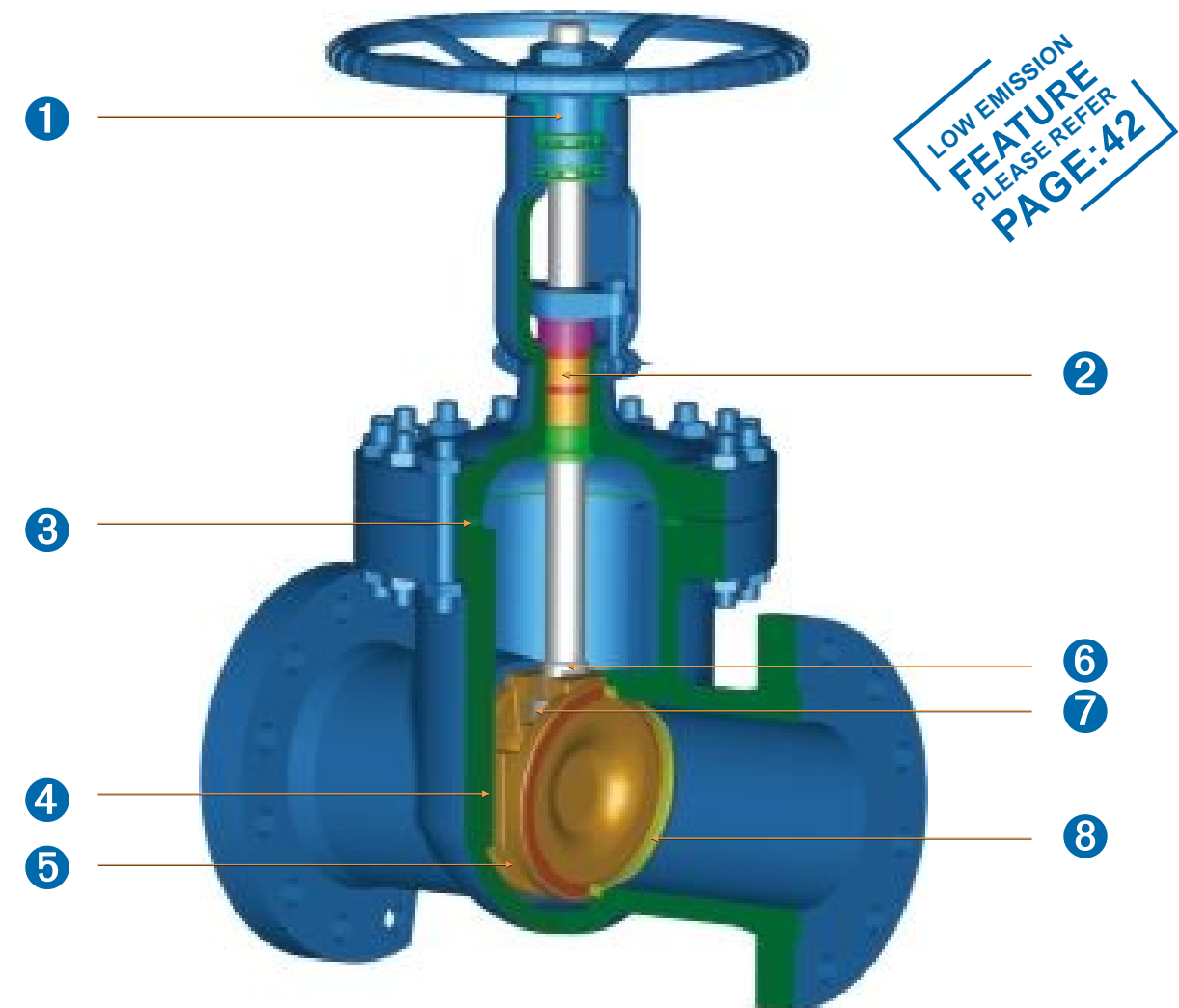

LOW EMISSION
FEATURE
PLEASE REFER
PAGE:42

- 1 Long thread stem nut to provide long thread life and permit the removal of hand wheel even at full open.
- 2 Spacer ring and single packing set for class 300 and above while only single packing set for class 150. Double packings can be provided on customer's requirement.
- 3 Corrugated steel gasket for 150lb valves, spiral wound gasket for 300lb & 600lb valves, and ring joint for 900lb & above valves or as a optional for the 600lb valves on customer request.
- 4 Integral guide rig inside body to assure self-centering of wedge during open or closing.
- 5 Flexible wedge to compensate for seat face distortion and body deformation due to pipe stress.
- 6 Anti blow-out stem design with collar.
- 7 Stem & wedge connection stronger than the thread area of stem.
- 8 Renewable seal welded seats with satellite 6 are standard design while screwed-in seats are optional.

Part	Standard	Low Temperature Service	Stainless Steel	High Temperature Service	Sour Service
BODY	ASTM A216-WCB	ASTM A352-LCC	ASTM A351-CF8M	ASTM A217-WC9	ASTM A216-WCB
BONNET	ASTM A216-WCB	ASTM A352-LCC	ASTM A351-CF8M	ASTM A217-WC9	ASTM A216-WCB
WEDGE	ASTM A216-WCB/CR13 OVERLAY ASTM A217-CA15(10"&Smaller)	ASTM A352-LCC/316 OVERLAY	ASTM A351-CF8M	ASTM A217-WC9/STL. OVERLAY	ASTM A216-WCB/CR13 OVERLAY-NC ASTM A217-CA15(10"&Smaller)-NC
STEM NUT	ASTM A439 D-2	ASTM A439 D-2	ASTM A439 D-2	ASTM A439 D-2	ASTM A439 D-2
GLAND FLANGE	ASTM A216-WCB	ASTM A352-LCB	ASTM A351-CF8	ASTM A216-WCB	ASTM A216-WCB
HANDWHEEL	DUCTILE IRON	DUCTILE IRON	DUCTILE IRON	DUCTILE IRON	DUCTILE IRON
SEAT RING	ASTM A105/STL. OVERLAY	ASTM A182-F316/STL. OVERLAY	ASTM A182-F316/STL. OVERLAY	ASTM A182-F22/STL. OVERLAY	ASTM A105/STL. OVERLAY
STEM	ASTM A182-F6a	ASTM A182-F316	ASTM A182-F316	ASTM A182-F6a	ASTM A182-F6a-NC
BACK SEAT	ASTM A276-420	ASTM A276-316	ASTM A276-316	ASTM A276-420	ASTM A276-420-NC
GLAND	ASTM A276-420	STAINLESS STEEL	ASTM A276-316	ASTM A276-420	ASTM A276-420-NC
GASKET	SPIRAL WOUND GRAPHITE	SPIRAL WOUND GRAPHITE	SPIRAL WOUND GRAPHITE	SPIRAL WOUND GRAPHITE	SPIRAL WOUND GRAPHITE
MIDDLE PACKING	GRAPHITE	GRAPHITE	GRAPHITE	GRAPHITE	GRAPHITE
TOP/BOTTOM PACKING	316+GRAPHITE	316+GRAPHITE	316+GRAPHITE	316+GRAPHITE	316+GRAPHITE
RETAINING NUT	CARBON STEEL	CARBON STEEL	STAINLESS STEEL	CARBON STEEL	CARBON STEEL
HANDWHEEL NUT	CARBON STEEL	CARBON STEEL	STAINLESS STEEL	CARBON STEEL	CARBON STEEL
BONNET STUD	ASTM A193-B7	ASTM A320-L7M	ASTM A193-B8	ASTM A193-B16	ASTM A193-B7M
BONNET NUT	ASTM A194-2H	ASTM A194-7M	ASTM A194-8	ASTM A194-4	ASTM A194-2HM
EYE BOLT	ASTM A193-B7	ASTM A320-L7M	ASTM A193-B8	ASTM A193-B16	ASTM A193-B7M
GLAND NUT	ASTM A194-2H	ASTM A194-7M	ASTM A194-8	ASTM A194-4	ASTM A194-2HM
GREASE FITTING	CARBON STEEL	CARBON STEEL	STAINLESS STEEL	CARBON STEEL	CARBON STEEL
EYE BOLT PIN	CARBON STEEL	STAINLESS STEEL	STAINLESS STEEL	STAINLESS STEEL	CARBON STEEL
RIVET	CARBON STEEL	CARBON STEEL	STAINLESS STEEL	CARBON STEEL	CARBON STEEL
NAME PLATE	STAINLESS STEEL	STAINLESS STEEL	STAINLESS STEEL	STAINLESS STEEL	STAINLESS STEEL

Notes: Above materials are general, when ordered, Please contact NEWAY Sales or technical team to confirm the details.

Class 150 Cast Carbon Steel Gate Valve

API 600 Design,
Bolted Bonnet, OS&Y,
Screwed-in Back seat, Rising Stem,
Non-rising Handwheel,
Flexible Wedge

Figure NO.:

G1R,WCB/NO.8
G1B,WCB/NO.8

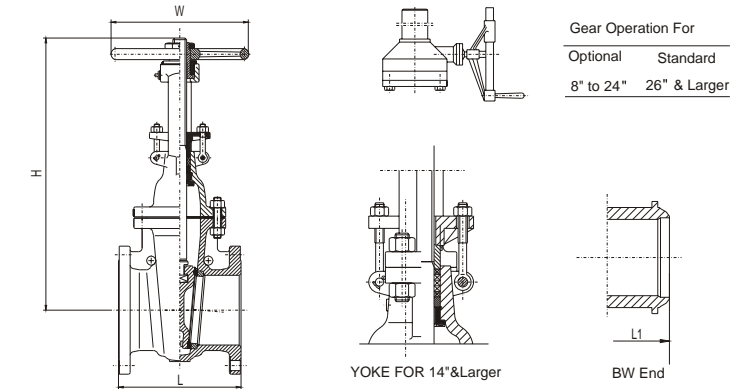

NPS	in	2"	2-1/2"	3"	4"	5"	6"	8"	10"	12"	14"	16"	18"	20"	24"	26"	28"	30"	32"	36"	40"	42"	48"
DN	mm	50	65	80	100	125	150	200	250	300	350	400	450	500	600	650	700	750	800	900	1000	1050	1200
L(RF)	in	7	7.5	8	9	10	10.5	11.5	13	14	15	16	17	18	20	22	24	24	26	28	30	31	34
L1(BW)	in	8.5	9.5	11.12	12	15	15.88	16.5	18	19.75	22.5	24	26	28	32	34	36	36	38	40	42	43	46
W	in	8	8	10	12	12	12	14	16	18	20	22	24	27	30	24	24	24	24	24	24	32	32
	mm	200	200	250	300	300	300	350	400	450	500	550	600	680	760	610	610	610	610	610	610	610	610
H	in	15.2	17.1	18.9	23	26.8	30.1	37.6	45.2	53.2	59.4	67	74.5	83.4	98.4	110	117	124	129	146	157	190	233
	mm	386.5	434.5	480.5	584.5	681	765	956	1149	1350.5	1508	1703	1892	2119	2500	2806	2960	3148	3281	3721	3980	4820	5920
WT(RF)	Kg	19	26	35	49	64	81	127	204	291	400	486	610	788	1144	1570	1900	2540	2958	3380	4815	5300	7110
WT(BW)	Kg	15	18	26	41	58	69	108	156	248	365	482	587	752	1178	1521	1838	2261	2490	3310	4840	5275	7050

* (1) For size of larger than 48" valve, Please contact Neway sales or engineering team for details.

Class 300 Cast Carbon Steel Gate Valve

API 600 Design,
Bolted Bonnet, OS&Y,
Screwed-in Back seat, Rising Stem,
Non-rising Handwheel,
Flexible Wedge

Figure NO.:

G3R,WCB/NO.8
G3B,WCB/NO.8

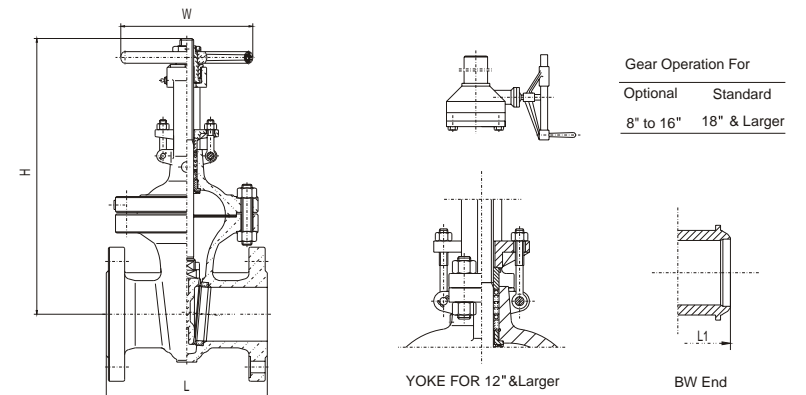

NPS	in	2"	2-1/2"	3"	4"	5"	6"	8"	10"	12"	14"	16"	18"	20"	24"	26"	28"	30"	32"	36"	40"	42"	48"
DN	mm	50	65	80	100	125	150	200	250	300	350	400	450	500	600	650	700	750	800	900	1000	1050	1200
L-L1 (RF-BW)	in	8.5	9.5	11.12	12	15	15.88	16.5	18	19.75	30	33	36	39	45	49	53	55	60	68	76	78	88
	mm	216	241	283	305	381	403	419	457	502	762	838	914	991	1143	1245	1346	1397	1524	1727	1930	1981	2235
W	in	8	8	10	10	12	14	16	18	20	22	24	24	24	24	24	24	24	32	40	40	40	40
	mm	200	200	250	250	300	350	400	450	500	550	600	610	610	610	610	610	610	810	1000	1000	1000	1000
H	in	16.1	17.8	20	24.1	26.4	31.7	39.4	47.6	55.7	62.3	67.9	77.1	86.4	102.3	117.6	122.8	126.2	145.4	161.6	179	186.6	211.5
	mm	410	453	509	612	670	805	1000	1209	1416	1582	1725	1959	2194	2598	2986	3120	3205	3692	4104	4547	4739	5373
WT(RF)	Kg	26	35	52	75	102	147	235	350	472	683	950	1145	1634	2660	3090	3312	3597	4850	6850	8460	9500	12400
WT(BW)	Kg	17	26	52	74	102	113	164	344	485	565	805	1058	1412	2304	2540	2725	3057	4122	4990	6160	6800	9000

* (1) For size of larger than 48" valve, Please contact Neway sales or engineering team for details.

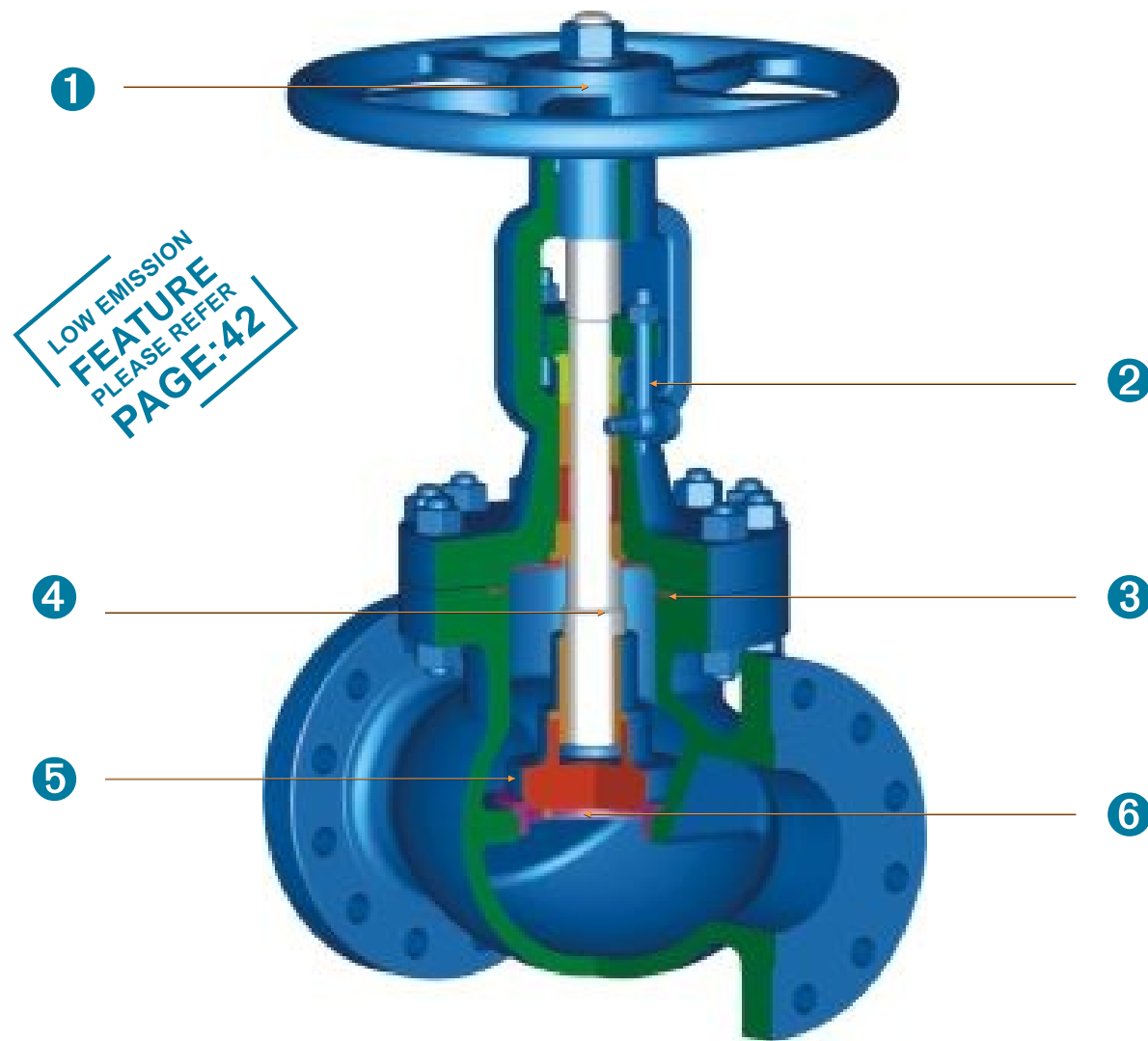

- 1 Impact handwheel supplied by manufacturer's option or on customer request.
- 2 Gland eyebolts are mounted to swing aside to facilitate packing maintenance.
- 3 Male and female bonnet joints for 150lb to 600lb valves, and ring joint for the 900lb & above valves or as an optional for 600lb valves on customer request.
- 4 Anti blow-out stem design with conical backseat surface to permit repacking of valve in the fully open position.
- 5 Plug seat surface is standard disc design as well as spherical and flat seating surface is optional on customer request.
- 6 Seat face with satellite 6 is standard design.

Part	Standard	Low Temperature Service	Stainless Steel	High Temperature Service	Sour Service
BODY	ASTM A216-WCB	ASTM A352-LCC	ASTM A351-CF8M	ASTM A217-WC9	ASTM A216-WCB
BONNET	ASTM A216-WCB	ASTM A352-LCC	ASTM A351-CF8M	ASTM A217-WC9	ASTM A216-WCB
DISC	ASTM A182-F6a ASTM A105/ER410 (FOR 4" & Larger)	ASTM A182-F316	ASTM A182-F316	ASTM A182-F22/STL.OVERLAY	ASTM A182-F6a-NC
STEM NUT	ASTM A439 D-2	ASTM A439 D-2	ASTM A439 D-2	ASTM A439 D-2	ASTM A439 D-2
GLAND FLANGE	ASTM A216-WCB	ASTM A352-LCB	ASTM A351-CF8	ASTM A216-WCB	ASTM A216-WCB
HANDWHEEL	DUCTILE IRON	DUCTILE IRON	DUCTILE IRON	DUCTILE IRON	DUCTILE IRON
IMPACT BLOCK	CARBON STEEL	CARBON STEEL	CARBON STEEL	CARBON STEEL	CARBON STEEL
RETAIN PLATE	CARBON STEEL	CARBON STEEL	CARBON STEEL	CARBON STEEL	CARBON STEEL
SEAT RING	ASTM A105/STL.OVERLAY	ASTM A182-F316/STL.OVERLAY	ASTM A182-F316/STL.OVERLAY	ASTM A182-F22/STL.OVERLAY	ASTM A105/STL.OVERLAY
STEM	ASTM A182-F6a	ASTM A182-F316	ASTM A182-F316	ASTM A182-F6a	ASTM A182-F6a-NC
BACK SEAT	ASTM A276-420	ASTM A276-316	ASTM A276-316	ASTM A276-420	ASTM A276-420-NC
GLAND	ASTM A276-420	STAINLESS STEEL	ASTM A276-316	ASTM A276-420	ASTM A276-420-NC
SPACE RING	ASTM A276-420	ASTM A276-316	ASTM A276-316	ASTM A276-420	ASTM A276-420-NC
DISC NUT	ASTM A276-420	ASTM A276-316	ASTM A276-316	ASTM A276-420	ASTM A276-420-NC
STEM WASHER	ASTM A276-430	NO	NO	ASTM A276-430	STAINLESS STEEL
HANDWHEEL WASHER	CARBON STEEL	CARBON STEEL	STAINLESS STEEL	CARBON STEEL	CARBON STEEL
BONNET GASKET	SOFT STEEL	ASTM A276-316	ASTM A276-316	SOFT STEEL	SOFT STEEL
PACKING	316+GRAPHITE	316+GRAPHITE	316+GRAPHITE	316+GRAPHITE	316+GRAPHITE
PACKING	GRAPHITE	GRAPHITE	GRAPHITE	GRAPHITE	GRAPHITE
BONNET STUD	ASTM A193-B7	ASTM A320-L7M	ASTM A193-B8	ASTM A193-B16	ASTM A193-B7M
BONNET NUT	ASTM A194-2H	ASTM A194-7M	ASTM A194-8	ASTM A194-4	ASTM A194-2HM
EYE BOLT	ASTM A193-B7	ASTM A320-L7M	ASTM A193-B8	ASTM A193-B16	ASTM A193-B7M
GLAND NUT	ASTM A194-2H	ASTM A194-7M	ASTM A194-8	ASTM A194-4	ASTM A194-2HM
HANDWHEEL NUT	CARBON STEEL	CARBON STEEL	STAINLESS STEEL	CARBON STEEL	CARBON STEEL
EYE BOLT PIN	CARBON STEEL	STAINLESS STEEL	STAINLESS STEEL	STAINLESS STEEL	CARBON STEEL
RIVET	CARBON STEEL	CARBON STEEL	STAINLESS STEEL	CARBON STEEL	CARBON STEEL
NAME PLATE	STAINLESS STEEL	STAINLESS STEEL	STAINLESS STEEL	STAINLESS STEEL	STAINLESS STEEL

Notes: Above materials are general, when ordered, Please contact NEWAY Sales or technical team to confirm the details.

Class 150 Cast Carbon Steel Globe Valve

BS 1873 Design,
Bolted Bonnet, OS&Y,
Screwed-in Back Seat,
Rising Stem and Handwheel,
Swivel Disc

Figure NO.:

GL1R,WCB/NO.8
GL1B,WCB/NO.8

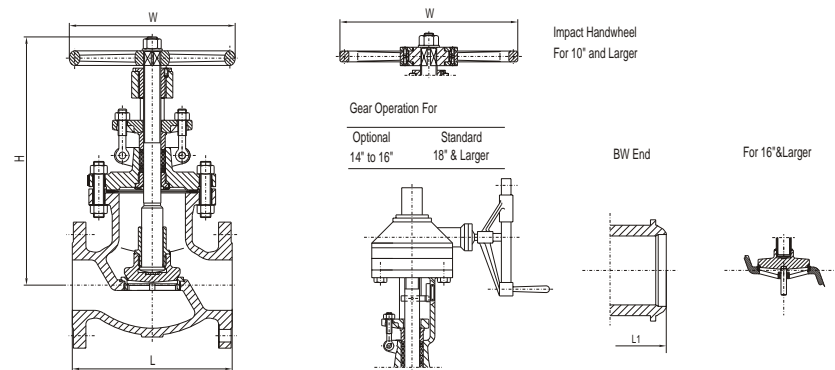

NPS	in	2"	2-1/2"	3"	4"	5"	6"	8"	10"	12"	14"	16"	18"	20"	24"
DN	mm	50	65	80	100	125	150	200	250	300	350	400	450	500	600
L-L1 (RF-BW)	in	8	8.5	9.5	11.5	14	16	19.5	24.5	27.5	31	36	38.5	38.5	51
	mm	203	216	241	292	356	406	495	622	699	787	914	978	978	1295
W	in	8	10	10	12	14	14	16	20	20	22	26	24	24	31.9
	mm	200	250	250	300	350	350	400	500	500	560	650	610	610	810
H	in	13.3	14.7	15.6	18.7	19.6	20.6	23.1	29.1	33.9	37.4	39.2	44.9	49.7	60
	mm	338	373	396	476	497	524	588	738	862	950	994	1140	1262	1524
WT(RF)	Kg	21	29	35	58	78	104	162	289	485	550	724	1400	2600	3700
WT(BW)	Kg	17	20	30	47	71	86	138	219	362	491	650	1250	2300	3250

Class 300 Cast Carbon Steel Globe Valve

BS 1873 Design,
Bolted Bonnet, OS&Y,
Screwed-in Back Seat,
Rising Stem and Handwheel,
Swivel Disc

Figure NO.:

GL3R,WCB/NO.8
GL3B,WCB/NO.8

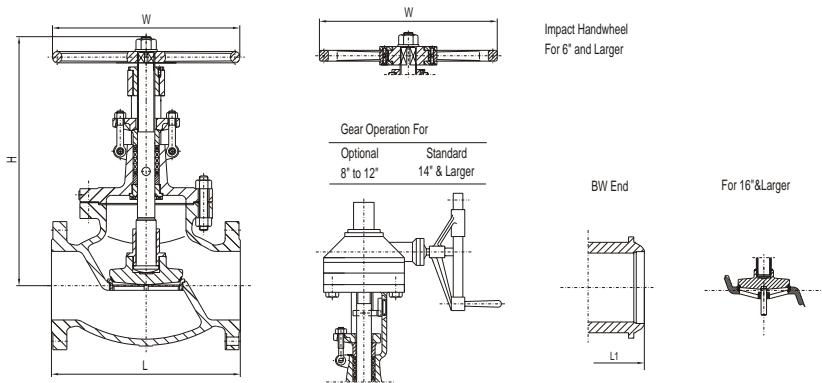

NPS	in	2"	2-1/2"	3"	4"	5"	6"	8"	10"	12"	14"	16"	18"	20"
DN	mm	50	65	80	100	125	150	200	250	300	350	400	450	500
L-L1 (RF-BW)	in	10.5	11.5	12.5	14	15.75	17.5	22	24.5	28	33	34	38.5	40
	mm	267	292	318	356	400	445	559	622	711	838	864	978	1016
W	in	8	10	10	14	18	20	22	24	26	24	24	38.5	40
	mm	200	250	250	350	450	500	560	600	650	610	610	610	810
H	in	13.9	15.3	16.6	19.5	22.7	26.6	35.9	37.4	40.6	44.5	51.6	57.5	64.3
	mm	353.5	388.5	420.5	495.5	576.5	674.5	911.5	949	1032	1130	1310	1460	1632
WT(RF)	Kg	26	38	51	76	125	173	297	500	724	1125	1650	2700	3650
WT(BW)	Kg	21	29	38	59	104	137	237	432	632	975	1450	2400	3200

Class 600 Cast Carbon Steel Globe Valve

BS 1873 Design,
Bolted Bonnet, OS&Y,
Screwed-in Back Seat,
Rising Stem and Handwheel,
Swivel Disc

Figure NO.:

GL6R,WCB/NO.8
GL6B,WCB/NO.8

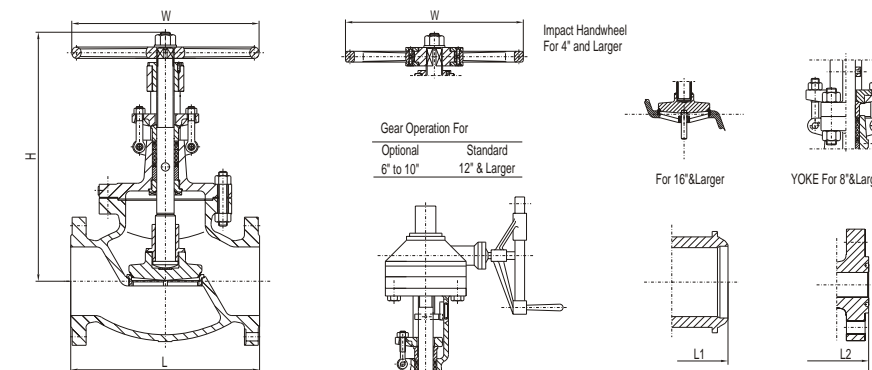

NPS	in	2"	2-1/2"	3"	4"	5"	6"	8"	10"	12"	14"	16"	18"
DN	mm	50	65	80	100	125	150	200	250	300	350	400	450
L-L1 (RF-BW)	in	11.5	13	14	17	20	22	26	31	33	35	39	43
	mm	292	330	356	432	508	559	660	787	838	889	991	1092
L2 (RTJ)	in	11.62	13.12	14.12	17.12	20.12	22.12	26.12	31.12	33.12	35.12	39.12	43.1
	mm	295	333	359	435	511	562	663	790	841	892	994	1095
W	in	10	10	14	18	20	22	24	28	24	24	30	32
	mm	250	250	350	450	500	560	600	700	610	610	762	810
H	in	15.6	17.6	19.5	23.6	27.6	31.1	39.9	46.5	55	57.1	63.4	70.9
	mm	396.5	446	495.5	599	700	791	1014	1180	1397	1450	1610	1801
WT(RF)	Kg	37	50	62	150	187	294	543	1006	1350	1620	2160	3300
WT(BW)	Kg	30	40	58	132	142	227	460	729	1060	1330	1750	2800

Class 900 Cast Carbon Steel Globe Valve

BS 1873 Design,
Bolted Bonnet, OS&Y,
Screwed-in Back Seat,
Rising Stem and Handwheel,
Swivel Disc

Figure NO.:

GL9R,WCB/NO.5
GL9J,WCB/NO.5
GL9B,WCB/NO.5

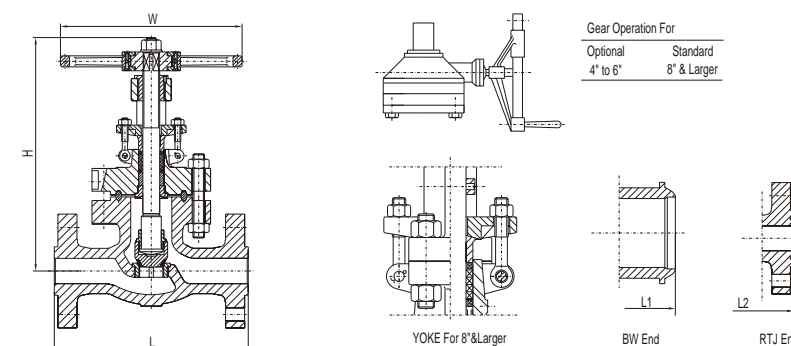

NPS	in	2"	2-1/2"	3"	4"	6"	8"	10"	12"	14"	16"
DN	mm	50	65	80	100	150	200	250	300	350	400
L-L1 (RF-BW)	in	14.5	16.5	15	18	24	29	33	38	40.5	44.5
	mm	368	419	381	457	610	737	838	965	1029	1130
L2 (RTJ)	in	14.62	16.62	15.12	18.12	24.12	29.12	33.1	38.1	40.9	44.9
	mm	371	422	384	460	613	740	841	968	1038	1140
W	in	14	14	18	20	24	24	24	31.9	31.9	31.9
	mm	350	350	450	500	610	610	610	810	810	810
H	in	23.2	26	27.5	31.3	43.6	46.6	58.2	69.1	76.1	87
	mm	590	660	699	795	1108	1184	1479	1755	1934	2210
WT(RF)	Kg	95	138	110	197	435	720	1070	1920	2670	3520
WT(BW)	Kg	75	85	112	158	360	597	890	1690	2390	3170

Class 1500 Cast Carbon Steel Globe Valve

BS 1873 Design,
Bolted Bonnet, OS&Y,
Screwed-in Back Seat,
Rising Stem and Handwheel,
Swivel Disc

Figure NO.:

GL15R,WCB/NO.5
GL15J,WCB/NO.5
GL15B,WCB/NO.5

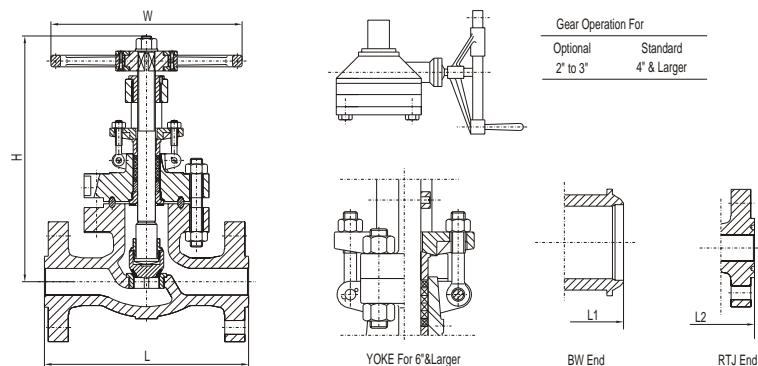

NPS	in	2"	2-1/2"	3"	4"	6"	8"	10"	12"
DN	mm	50	65	80	100	150	200	250	300
L-L1 (RF-BW)	in	14.5	16.5	18.5	21.5	27.75	32.75	39	44.5
	mm	368	419	470	546	705	832	991	1130
L2 (RTJ)	in	14.62	16.62	18.62	21.62	28.00	33.13	39.4	45.1
	mm	371	422	473	549	711	842	1000	1146
W	in	14	14	20	22	24	24	31.9	31.9
	mm	350	350	500	560	610	610	810	810
H	in	21.7	22.5	22.9	31.3	50.3	77.2	96.5	114.3
	mm	550	572	582	795	1278	1960	2450	2904
WT(RF)	Kg	85	138	215	350	560	990	1530	2570
WT(BW)	Kg	75	112	129	299	462	830	1330	2270

Class 2500 Cast Carbon Steel Globe Valve

BS 1873 Design,
Bolted Bonnet, OS&Y,
Screwed-in Back Seat,
Rising Stem and Handwheel,
Swivel Disc

Figure NO.:

GL25R,WCB/NO.5
GL25J,WCB/NO.5
GL25B,WCB/NO.5

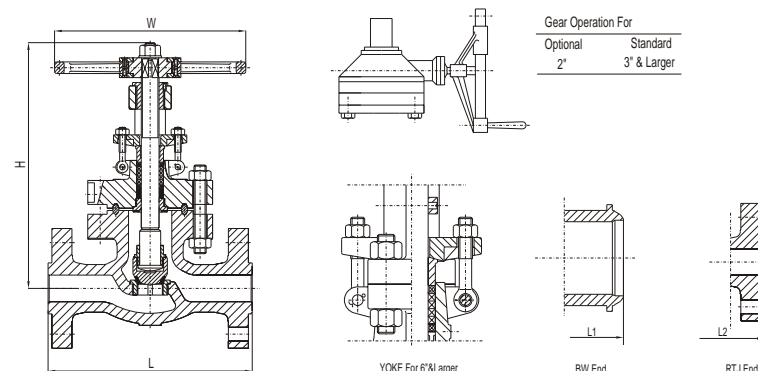

NPS	in	2"	2-1/2"	3"	4"	6"	8"	10"
DN	mm	50	65	80	100	150	200	250
L-L1 (RF-BW)	in	17.75	20	22.75	26.5	36	40.25	50
	mm	451	508	578	673	914	1022	1270
L2(RTJ)	in	17.88	20.25	23.00	26.88	36.50	40.88	50.9
	mm	454	514	584	683	927	1038	1292
W	in	16	20	22	24	24	24	31.9
	mm	400	500	560	610	610	610	810
H	in	28.3	31.5	34.8	49.6	75	97	122.4
	mm	720	800	885	1260	1905	2465	3108
WT(RF)	Kg	176	264	308	759	1990	4390	5290
WT(BW)	Kg	141	214	238	644	1700	3950	4390

LOW EMISSION
FEATURE
PLEASE REFER
PAGE:42

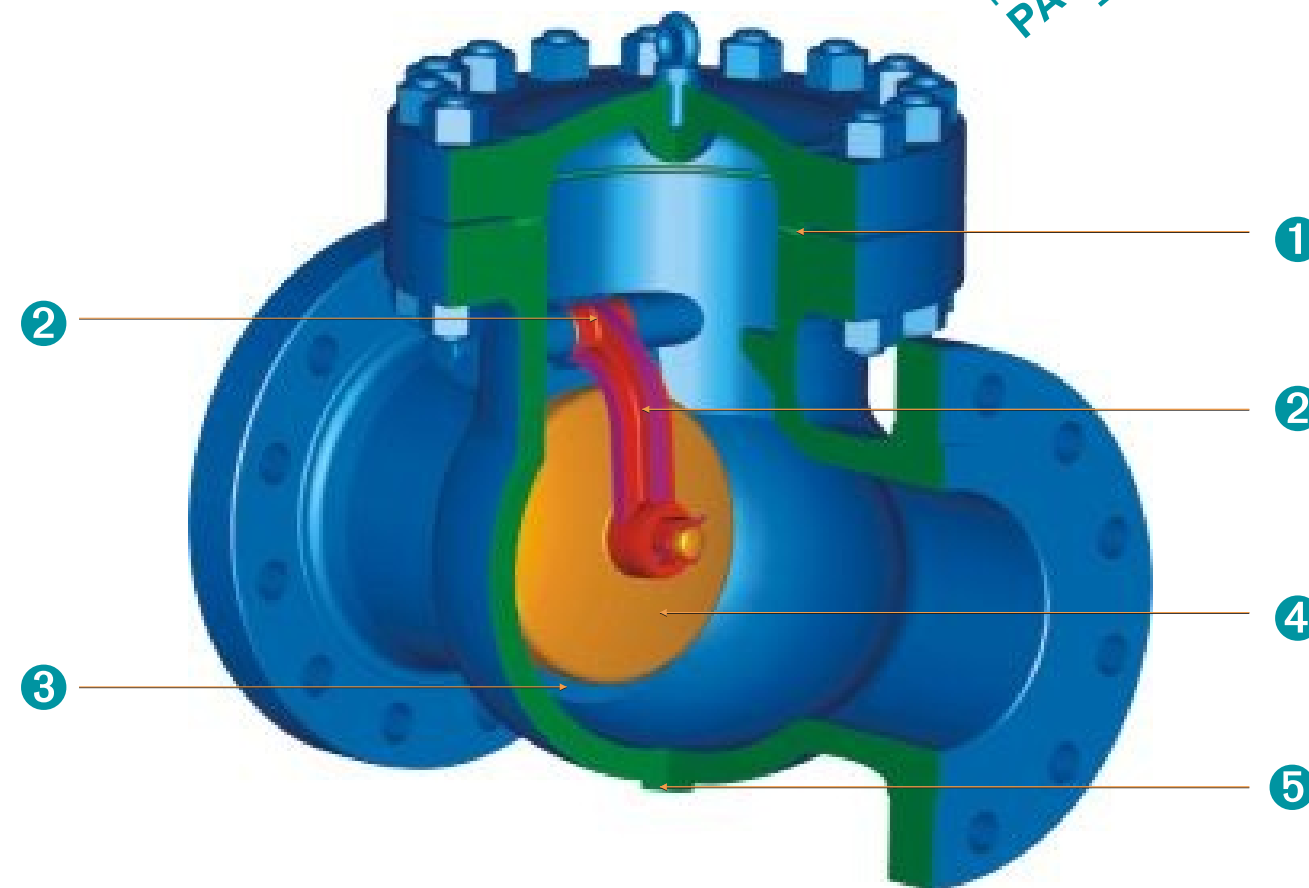

- 1 Corrugated steel gasket for 150lb valves, spiral wound gasket for 300lb & 600lb valves, and ring joint for 900lb & above valves or as an optional for the 600lb valves on customer request.
- 2 A hinge and hinge pin provided and mounted so as to permit full movement of the disc.
- 3 Standard renewable seal welded seat with satellite 6 while optional screwed-in seat.
- 4 Standard swing type disc only in horizontal pipe lines handling liquids.
- 5 Normal provision for a drain tapping at location G while additional bosses on customer request.

Part	Standard	Low Temperature Service	Stainless Steel	High Temperature Service	Sour Service
BODY	ASTM A216-WCB	ASTM A352-LCC	ASTM A351-CF8M	ASTM A217-WC9	ASTM A216-WCB
COVER	ASTM A216-WCB	ASTM A352-LCC	ASTM A351-CF8M	ASTM A217-WC9	ASTM A216-WCB
DISC	ASTM A217-CA15(4"&Smaller) &ASTM A216-WCB/ER410	ASTM A352-LCC/316 OVERLAY	ASTM A351-CF8M	ASTM A217-WC9/STL. OVERLAY	ASTM A217-CA15-NC(4"&Smaller) &ASTM A216-WCB/ER410-NC
HINGE	ASTM A216-WCB	ASTM A352-LCC	ASTM A351-CF8M	ASTM A217-WC9	ASTM A216-WCB
SEAT RING	ASTM A105/STL. OVERLAY	ASTM A182-F316/STL. OVERLAY	ASTM A182-F316/STL. OVERLAY	ASTM A182-F22/STL. OVERLAY	ASTM A105/STL. OVERLAY
HINGE PIN	ASTM A276-410	ASTM A276-316	ASTM A276-316	ASTM A276-410	ASTM A276-410-NC
PLUG FOR HINGE PIN	CARBON STEEL	ASTM A276-316	ASTM A276-316	STAINLESS STEEL	CARBON STEEL
WASHER	STAINLESS STEEL	ASTM A276-316	ASTM A276-316	STAINLESS STEEL	STAINLESS STEEL
DISC NUT	ASTM A276-420	ASTM A276-316	ASTM A276-316	ASTM A276-420	STAINLESS STEEL
DISC WASHER	ASTM A276-420	ASTM A276-316	ASTM A276-316	ASTM A276-420	STAINLESS STEEL
DISC SPLIT PIN	ASTM A276-420	ASTM A276-316	ASTM A276-316	ASTM A276-420	STAINLESS STEEL
BONNET RING JOINT	SOFT STEEL	ASTM A276-316	ASTM A276-316	ASTM A276-304	SOFT STEEL
BONNET STUD	ASTM A193-B7	ASTM A320-L7M	ASTM A193 B8	ASTM A193-B16	ASTM A193-B7M
BONNET NUT	ASTM A194-2H	ASTM A194-7M	ASTM A194 8	ASTM A194-4	ASTM A194-2HM
RIVET	CARBON STEEL	CARBON STEEL	STAINLESS STEEL	CARBON STEEL	CARBON STEEL
NAME PLATE	STAINLESS STEEL	STAINLESS STEEL	STAINLESS STEEL	STAINLESS STEEL	STAINLESS STEEL
HOOK SCREW	CARBON STEEL	CARBON STEEL	STAINLESS STEEL	CARBON STEEL	CARBON STEEL

Notes: Above materials are general, when ordered, Please contact NEWAY Sales or technical team to confirm the details.

Class 150 Cast Carbon Steel Check Valve

BS 1868 Design, Bolted Cover, Swing Type Disc

Figure NO.:

S1R,WCB/NO.8
S1B,WCB/NO.8

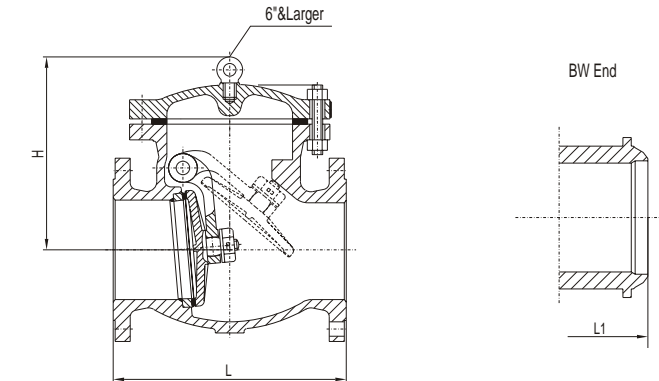

NPS	in	2"	2-1/2"	3"	4"	5"	6"	8"	10"	12"	14"	16"	18"	20"	24"	26"	28"	30"	32"	36"	40"	42"	48"
DN	mm	50	65	80	100	125	150	200	250	300	350	400	450	500	600	650	700	750	800	900	1000	1050	1200
L-L1 (RF-BW)	in	8	8.5	9.5	11.5	13	14	19.5	24.5	27.5	31	34	38.5	38.5	51	51	57	60	68	77	85	89	101
	mm	203	216	241	292	330	356	495	622	699	787	864	978	978	1295	1295	1448	1524	1727	1956	2159	2261	2566
H	in	5.9	6.6	6.7	8	9.1	11.7	13.8	15.3	17.2	18.8	20.7	22.9	24.7	34.6	35.8	36.8	38.2	49.2	54.2	55.5	57.8	64.6
	mm	150.5	168	171	204	230	296.5	351.5	389.5	437.5	476.5	525	582	627	880	910	935	970	1250	1377	1410	1468	1642
WT(RF)	Kg	15	22	28	42	57	79	131	177	282	380	542	632	855	970	1276	1600	2020	2430	3130	4230	5030	6680
WT(BW)	Kg	10	12	17	29	45	57	96	143	227	294	468	552	755	831	1120	1420	1760	2130	2930	3730	4430	5680

* (1) For size of larger than 48" valve, Please contact Neway sales or engineering team for details.

Class 300 Cast Carbon Steel Check Valve

BS 1868 Design, Bolted Cover, Swing Type Disc

Figure NO.:

S3R,WCB/NO.8
S3B,WCB/NO.8

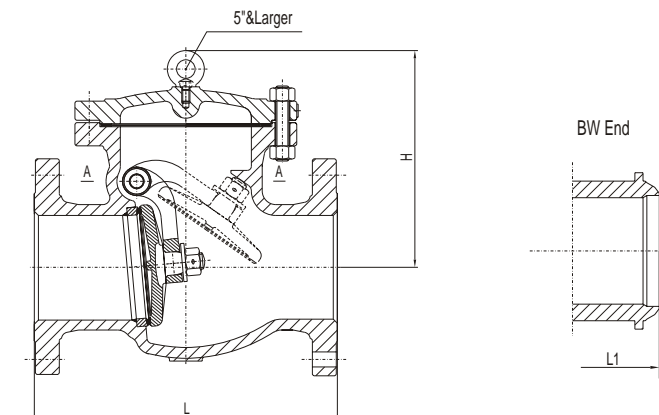

NPS	in	2"	2-1/2"	3"	4"	5"	6"	8"	10"	12"	14"	16"	18"	20"	24"	26"	28"	30"	32"	36"	40"	42"	48"
DN	mm	50	65	80	100	125	150	200	250	300	350	400	450	500	600	650	700	750	800	900	1000	1050	1200
L-L1 (RF-BW)	in	10.5	11.5	12.5	14	15.75	17.5	21	24.5	28	33	34	38.5	40	53	53	59	62.75	68	82	96	103	124
	mm	267	292	318	356	400	445	533	622	711	838	864	978	1016	1346	1346	1499	1594	1727	2083	2438	2617	3151
H	in	6.9	7.3	8.5	10.2	12	12.5	15	17.1	20.1	22.1	23.5	26.6	28.7	33.9	36.6	45.8	50	50.0	59.4	68.9	73.6	87.8
	mm	176	185	216	259	304	317	380	434	511	561	596	675	730	860	930	1163	1270	1270	1510	1750	1870	2230
WT(RF)	Kg	20	30	40	65	84	118	193	310	450	595	840	933	1320	1848	2375	2660	3680	3880	5030	6290	7050	9310
WT(BW)	Kg	16	22	30	53	73	101	157	232	414	455	766	774	960	1792	1995	2260	2780	3380	4430	5640	6150	8310

* (1) For size of larger than 48" valve, Please contact Neway sales or engineering team for details.

Class 600 Cast Carbon Steel Check Valve

BS 1868 Design, Bolted Cover, Swing Type Disc

Figure NO.:

S6R,WCB/NO.8
S6B,WCB/NO.8

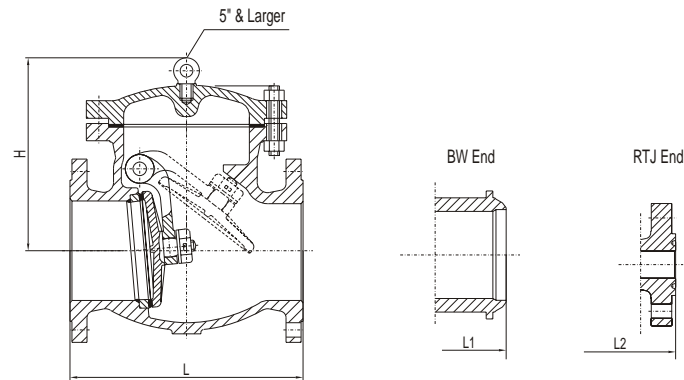

NPS	in	2"	2-1/2"	3"	4"	5"	6"	8"	10"	12"	14"	16"	18"	20"	24"	26"	28"	30"	32"	36"	40"	42"	48"
DN	mm	50	65	80	100	125	150	200	250	300	350	400	450	500	600	650	700	750	800	900	1000	1050	1200
L-L1 (RF-BW)	in	11.5	13	14	17	20	22	26	31	33	35	39	43	47	55	57	63	65	70	82	90	96	100
	mm	292	330	356	432	508	559	660	787	838	889	991	1092	1194	1397	1448	1600	1651	1778	2083	2286	2438	2540
L2 (RTJ)	in	11.62	13.12	14.12	17.12	20.12	22.12	26.12	31.12	33.12	35.12	39.12	43.12	47.25	55.38	57.5	63.5	65.5	70.6	82.6	-	-	-
	mm	295	333	359	435	511	562	663	790	841	892	994	1095	1200	1407	1461	1613	1664	1794	2099	-	-	-
H	in	7.2	8.3	9.1	10.4	11.6	14.7	16.8	20.4	22.4	24.5	26.8	29.6	38.4	43.7	43.7	46.9	52.1	53.8	60.7	67.0	70.9	85.5
	mm	184	210	232	263	295	374	426	517	569	622	680	752	975	1111	1110	1192	1324	1367	1542	1702	1800	2171
WT(RF)	kg	30	43	55	93	160	208	339	547	715	885	1310	1620	2120	3100	3800	4600	5500	6800	8100	8900	9800	11100
WT(BW)	kg	21	35	43	64	115	145	256	375	589	694	932	1279	1702	2497	3100	3900	4700	6000	7200	8100	9900	10200

* (1) For size of larger than 48" valve, Please contact Neway sales or engineering team for details.

Class 1500 Cast Carbon Steel Check Valve

BS 1868 Design, Bolted Cover, Swing Type Disc

Figure NO.:

S15R,WCB/NO.8
S15B,WCB/NO.8
S15J,WCB/NO.8

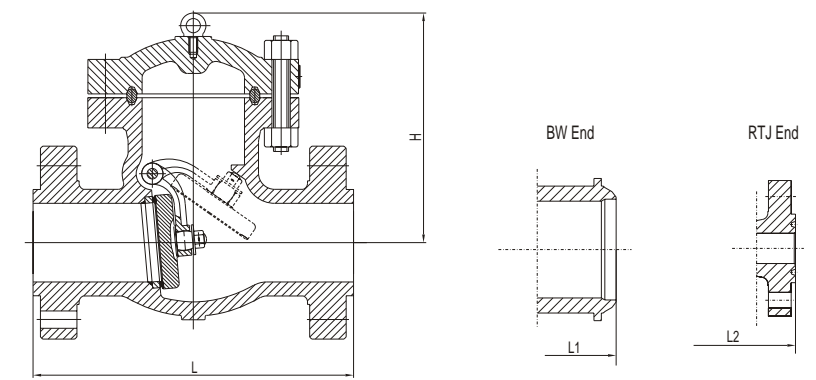

NPS	in	2"	2-1/2"	3"	4"	6"	8"	10"	12"	14"	16"	18"	20"	24"	26"	28"	30"
DN	mm	50	65	80	100	150	200	250	300	350	400	450	500	600	650	700	750
L-L1 (RF-BW)	in	14.5	16.5	18.5	21.5	27.75	32.75	39	44.5	49.5	54.5	60.5	65.5	76.5	82.0	87.5	93.0
	mm	368	419	470	546	705	832	991	1130	1257	1384	1537	1664	1943	2083	2222.5	2362
L2 (RTJ)	in	14.62	16.62	18.62	21.62	28.00	33.13	39.38	45.12	50.25	55.38	61.4	66.4	77.6	-	-	-
	mm	371	422	473	549	711	842	1000	1146	1276	1407	1559	1686	1972	-	-	-
H	in	11.7	11.8	13.4	16.2	20.1	26.8	29.8	33.7	37.4	40.1	45.2	50.6	60.6	70.6	80.7	90.7
	mm	296	300	341	412	511	680	756	857	950	1020	1147	1284	1539	1794	2049	2304
WT(RF)	kg	70	100	150	245	550	1010	1476	2280	3060	4500	6100	8000	9800	11600	13400	15200
WT(BW)	kg	50	77	115	190	452	750	1012	1780	2290	3500	5200	7500	8400	9300	10200	11100

Class 900 Cast Carbon Steel Check Valve

BS 1868 Design, Bolted Cover, Swing Type Disc

Figure NO.:

S9R,WCB/NO.8
S9B,WCB/NO.8
S9J,WCB/NO.8

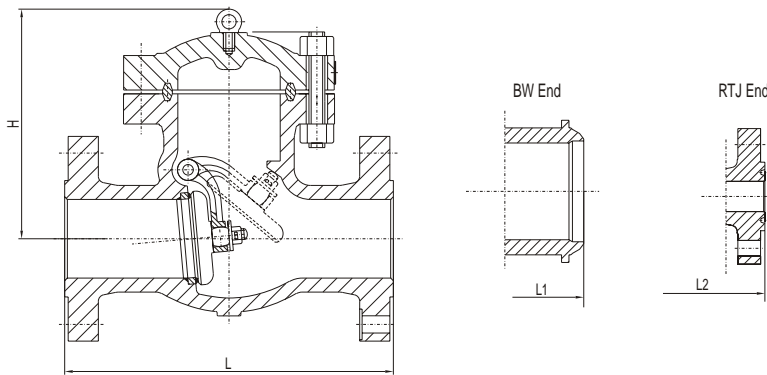

NPS	in	2"	2-1/2"	3"	4"	6"	8"	10"	12"	14"	16"	18"	20"	24"	26"	28"	30"	32"	36"
DN	mm	50	65	80	100	150	200	250	300	350	400	450	500	600	650	700	750	800	900
L-L1 (RF-BW)	in	14.5	16.5	15	18	24	29	33	38	40.5	44.5	48.0	52.0	61.0	65.0	69.0	73.0	77.0	84.9
	mm	368	419	381	457	610	737	838	965	1029	1130	1219	1321	1549	1651	1753	1854	1956	2156
L2 (RTJ)	in	14.62	16.62	15.12	18.12	24.12	29.12	33.12	38.12	40.88	44.88	48.5	52.5	61.7	65.9	69.9	73.9	-	-
	mm	371	422	384	460	613	740	841	968	1038	1140	1232	1333	1568	1673	1775	1876	-	-
H	in	11.7	11.8	11.8	12.9	17.4	19.8	26.1	30.5	30.8	33	33.0	36.7	36.4	44.1	54.0	59.9	65.8	71.7
	mm	296	300	300	327	441	502	664	775	782	838	839	932	924	1121	1372	1521	1671	1821
WT(RF)	kg	70	100	110	150	305	510	810	1120	1380	1900	3000	4000	5200	6600	7550	8850	10150	12750
WT(BW)	kg	50	68	77	113	230	387	632	901	1139	1613	2650	3550	4650	5630	6420	7510	8600	10780

Class 2500 Cast Carbon Steel Check Valve

BS 1868 Design, Bolted Cover, Swing Type Disc

Figure NO.:

S25R,WCB/NO.8
S25B,WCB/NO.8
S25J,WCB/NO.8

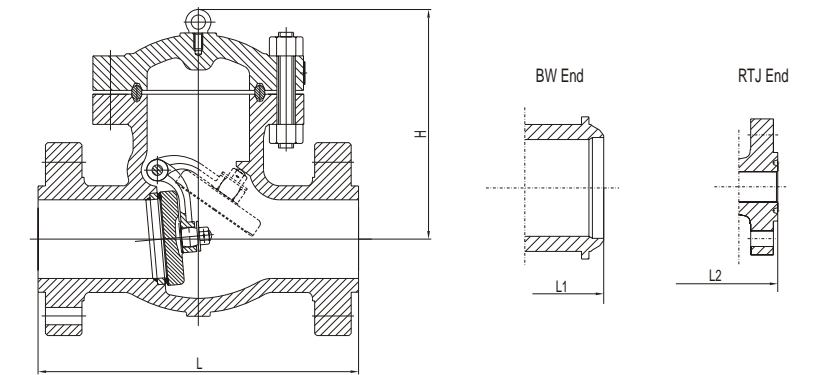

NPS	in	2"	2-1/2"	3"	4"	6"	8"	10"	12"	14"	16"	18"	20"	24"
DN	mm	50	65	80	100	150	200	250	300	350	400	450	500	600
L-L1 (RF-BW)	in	17.75	20	22.75	26.5	36	40.25	50	56	62.0	68.0	73.9	79.9	91.9
	mm	451	508	578	673	914	1022	1270	1422	1575	1727	1877	2029	2334
L2 (RTJ)	in	17.87	20.25	23.00	26.88	36.50	40.87	50.88	56.88	-	-	-	-	-
	mm	454	514	584	683	927	1038	1292	1445	-	-	-	-	-
H	in	16.4	16.5	17.4	18.9	20.1	28	33.5	39.4	47.2	51.2	55.1	59.1	63.0
	mm	416	419	441	479	511	711	851	1000	1200	1300	1400	1500	1600
WT(RF)	kg	145	240	330	650	806	2420	3750	5500	7400	9010	11200	12700	14000
WT(BW)	kg	110	190	260	535	665	1980	2980	4350	6200	8250	9400	11890	13000



Neway valves are produced mainly in two specialized valve plants, one for gate-, globe and check valves with capacity of 22000pc/month, one for butterfly and ball valves with 12000pc/month. Both size range between 1/2" ~ 64" and pressure rating between ANSI Class 150~2500 are available for our customer.

Prior to painting, Neway each valve is pressure tested with zero leakage acceptance criteria in accordance with API 598 or BS 6755. Neway can also provide some special tests on customer's request, which include up to 17MPa high pressure gas test, cryogenic, low & high temperature test, fire safe test, vacuum test and low emission test.

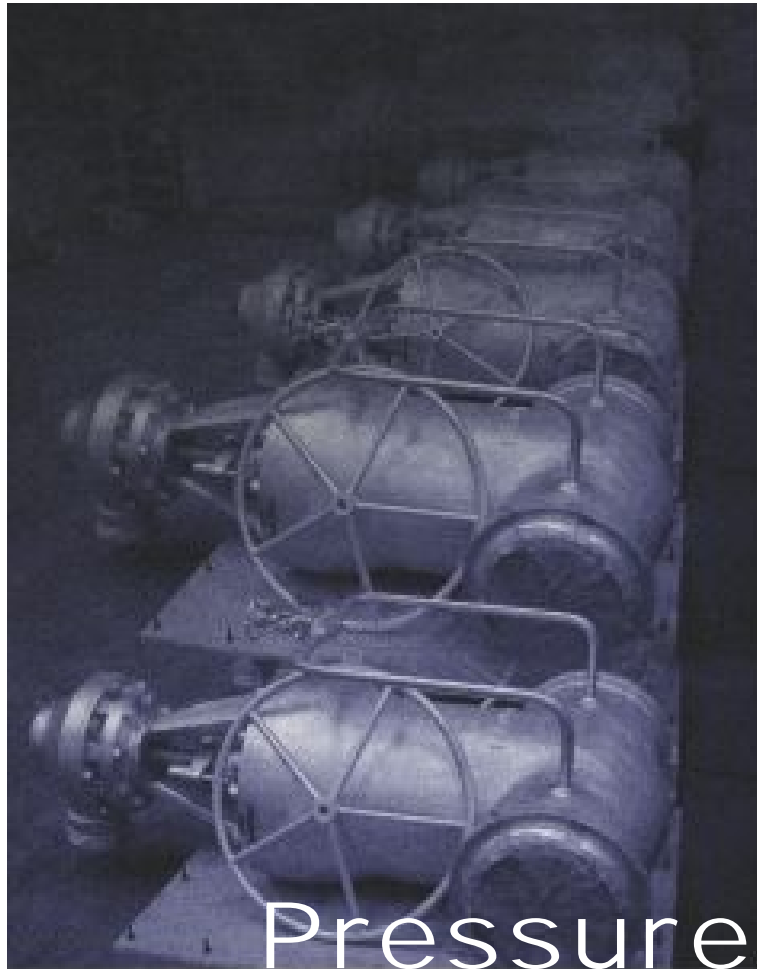

Pressure Seal Valve

A Stronger and Tighter valve with less weight, bulk and minimum maintenance, especially for high temperature, high pressure, services encountered in nuclear and fossil fuel power plants.

Cast Alloy Steel A217 Grade C12A Neway Gate, Globe & Check valves for servicing high pressure and high temperature power plant

To cater for the tendency of increasing power plant temperature and pressure to improve efficiencies and meet other high temperature industries, Neway had successfully developed cast alloy steel A217 Gr. C12A, the alloy exhibit excellent high-temperature properties based on the formation of a particular microstructure containing submicroscopic carbides, and the alloy is also much more resistant to thermal fatigue than the austenitic stainless steel because of its lower thermal expansion rating and higher thermal conductivity. Table 1 below show the allowable stresses (MPa) of several ASTM materials widely used in high temperature industries, and chemical compositions of C12A are shown in below table 2:

Table 2

Grade	Basic element											
	C	Si	Mn	S	P	Cr	V	N	Nb	Mo	Ni	AL
ASTM A217 C12A	0.08-0.12	0.20-0.50	0.30-0.60	≤ 0.01	≤ 0.03	8.00-9.50	0.18-0.25	0.03-0.07	0.06-0.10	0.85-1.05	≤ 0.4	≤ 0.04

To realize the required high temperature properties, in addition to the acceptable chemical composition and room temperature mechanical properties, a number of metallurgical issues must be properly

Table 1

Unit: Mpa

Temperature		Castings			Forgings		
°C	°F	WC9	C12	C12A	F22	F9	F91
38	100	138	177.2	146.9	147.6	167.5	167.5
260	500	133	169.6	133	141.3	160.7	166.2
343	650	131.7	164.8	126.9	139.3	155.8	161.3
482	900	109	113	111	108.9	113	131.7
538	1050	35.2	34.5	78.6	35.2	34.5	96.5
593	1100	22	22.8	60.7	22	22.8	71

Table 1: ASME code section II allowable stresses.

Note: Alloy C12A or F91 provide much higher allowable stresses in the temperature range from 482-593°C (900-1100°F)

executed including deoxidation practices, heat-treatment, welding process and PWHT(post welding heat treatment). Then, the special microstructure can be formed, Below Fig.1, 2 & 3 show the accepted microstructures:



Figure 1: Acceptable microstructure of castings (100X)⁽¹⁾



Figure 2: Acceptable microstructure after welding. (100X)⁽¹⁾



Figure 3: Acceptable microstructure in hot affected zone. (100X)⁽¹⁾

1. Deoxidization

To remove dissolved oxygen prior to pouring castings, small quantities of deoxidizers with high affinity for oxygen are added into melted metal so as to combine with the oxygen to form solid oxygen inclusion particles. The most common deoxidizers are manganese, silicon and aluminum. Only the proper processing, of course which is very difficult, can assure the final acceptable proportion microstructure, refer to Fig.1, and the high temperature creep strength.

2. Heat treatment

This processing is also one of the critical procedures to ensure the proper microstructure. In order to assure the high temperature properties, we perform strict heat treatment process, including heating time and heat preservation time.

3. Welding & Post-weld heat treatment (PWHT)

To achieve the proper creep resistance and toughness for the high chrome alloy, we make special weld process & PWHT process, including pre-heating temperature control & welding filler materials, especially PWHT, all processes are controlled precisely to form martensite in the weld and heat affected zone (HAZ). Figure 2 & 3 show the acceptable microstructure in weld & HAZ.

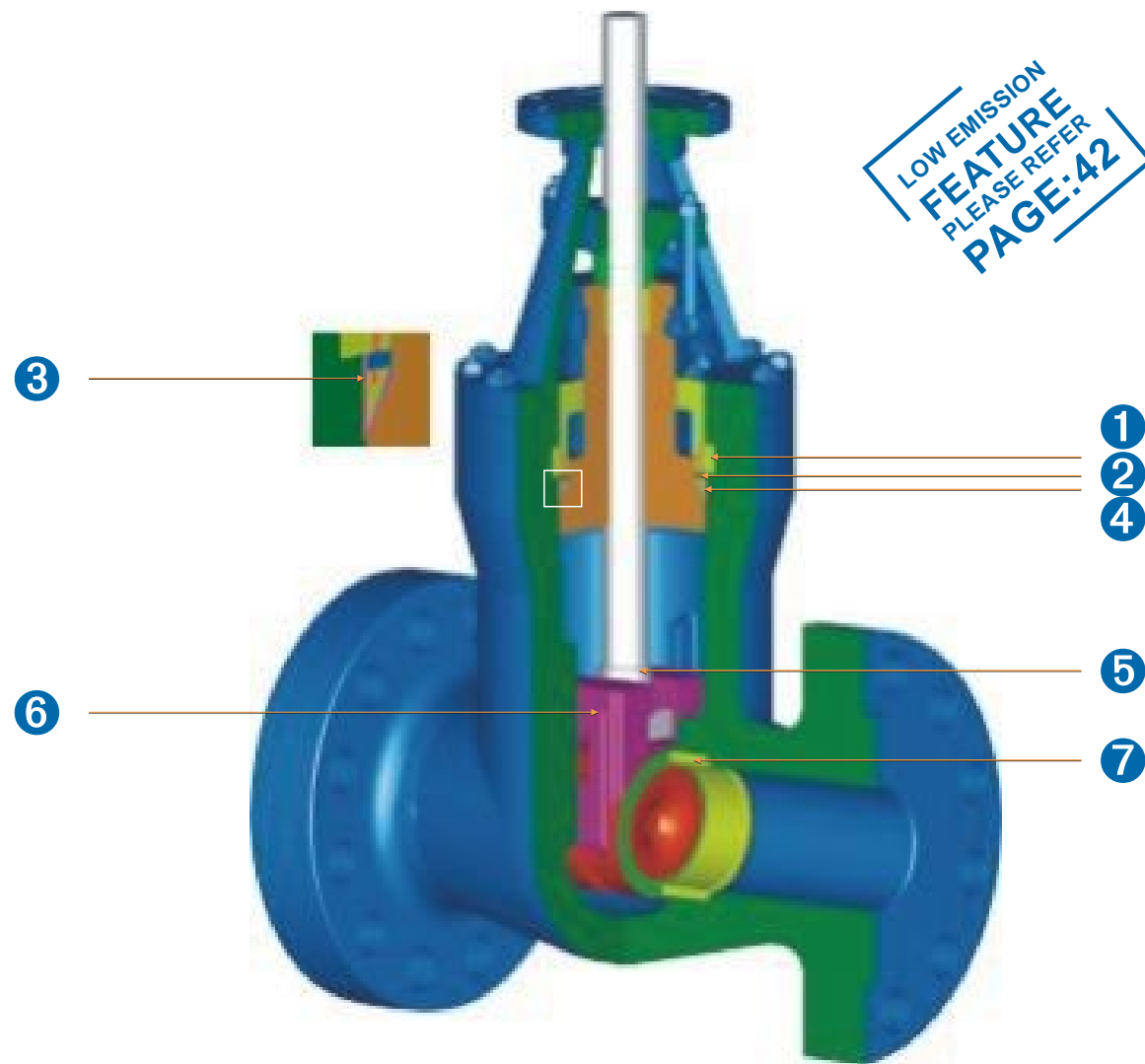

- 1 Segmental thrust ring absorb all the thrust applied by the internal pressure
- 2 Thrust ring to provide bearing surface and prevent deformation of the gaskets
- 3 Stainless steel inlay to ensure soundness and corrosion-resistance in the vital body sealing zone for carbon and alloy steel valves
- 4 Soft steel gasket seal to provide large contact area for perfect sealing
- 5 Anti blow-out stem design with collar
- 6 Flexible wedge to compensate for seat face distortion and body deformation due to pipe stress
- 7 Seat ring with satellite 6 overlay is standard design

Part	Standard	Stainless Steel	High temperature Service		
			ASTM A217-WC6	ASTM A217-WC9	ASTM A217-C12A
BODY	ASTM A216-WCB	ASTM A351-CF8M	ASTM A217-WC6	ASTM A217-WC9	ASTM A217-C12A
BONNET	ASTM A105	ASTM A182-F316	ASTM A182-F11	ASTM A182-F22	ASTM A217-C12A
WEDGE	ASTM A216-WCB/ER410 & ASTM A217-CA15	ASTM A351-CF8M/STL.OVERLAY	ASTM A217-WC6/ER410 & ASTM A217-CA15	ASTM A217-WC9/ER410 & ASTM A217-CA15	ASTM A217-C12A/ER410
STEM NUT	ASTM A439 D-2	ASTM A439 D-2	ASTM A439 D-2	ASTM A439 D-2	ASTM A439 D-2
GLAND FLANGE	ASTM A216-WCB	ASTM A351-CF8	ASTM A216-WCB	ASTM A216-WCB	ASTM A216-WCB
HANDWHEEL	DUCTILE IRON	DUCTILE IRON	DUCTILE IRON	DUCTILE IRON	DUCTILE IRON
SEAT RING	ASTM A105/STL.OVERLAY	ASTM A182-F316/STL.OVERLAY	ASTM A182-F11/STL.OVERLAY	ASTM A182-F22/STL.OVERLAY	ASTM A182-F6a/STL.OVERLAY
STEM	ASTM A182-F6a	ASTM A182-F316	ASTM A182-F6a	ASTM A182-F6a	ASTM A182-F6a
BONNET SEAL RING	ASTM A182-F304(4"&Smaller GRAPHITE)	ASTM A182-F316L(4"&Smaller GRAPHITE)	ASTM A182-F304(4"&Smaller GRAPHITE)	ASTM A182-F304(4"&Smaller GRAPHITE)	ASTM A182-F304(4"&Smaller GRAPHITE)
GLAND	ASTM A276-420	ASTM A276-316	ASTM A276-420	ASTM A276-420	ASTM A276-420
RETAINING NUT FOR STEM NUT	CARBON STEEL	STAINLESS STEEL	CARBON STEEL	CARBON STEEL	CARBON STEEL
YOKE	ASTM A216-WCB	ASTM A351-CF8	ASTM A216-WCB& ASTM A217-WC6	ASTM A216-WCB& ASTM A217-WC6	ASTM A216-WCB
PACKING	GRAPHITE	GRAPHITE	GRAPHITE	GRAPHITE	GRAPHITE
BONNET SEPARATE RING	CARBON STEEL	ASTM A276-420	ANSI 4140	ANSI 4140	ANSI 4140
CLIPPING RING	ASTM A216-WCB	ASTM A351-CF8	ASTM A217-WC6	ASTM A217-WC6	ASTM A276-420
HANDWHEEL NUT	CARBON STEEL	STAINLESS STEEL	CARBON STEEL	CARBON STEEL	CARBON STEEL
BONNET STUD	ASTM A193-B7	ASTM A193-B8	ASTM A193-B16	ASTM A193-B16	ASTM A193-B16
BONNET NUT	ASTM A194-2H	ASTM A194-8	ASTM A194-4	ASTM A194-4	ASTM A194-4
YOKE STUD	ASTM A193-B7	ASTM A193-B8	ASTM A193-B16	ASTM A193-B16	ASTM A193-B16
YOKE NUT	ASTM A194-2H	ASTM A194-8	ASTM A194-4	ASTM A194-4	ASTM A194-4
EYE BOLT	ASTM A193-B7	ASTM A193-B8	ASTM A193-B16	ASTM A193-B16	ASTM A193-B16
GLAND NUT	ASTM A194-2H	ASTM A194-8	ASTM A194-4	ASTM A194-4	ASTM A194-4
BONNET THRUST RING	CARBON STEEL	ASTM A276-420	AISI 4140	AISI 4140	ANSI 4140
SUPPORTING COVER	ASTM A105	ASTM A276-420	AISI 4140	AISI 4140	ANSI 4140
CLIPPING RING BOLT	CARBON STEEL	STAINLESS STEEL	STAINLESS STEEL	STAINLESS STEEL	STAINLESS STEEL
RIVET	CARBON STEEL	STAINLESS STEEL	CARBON STEEL	CARBON STEEL	STAINLESS STEEL
NAME PLATE	STAINLESS STEEL	STAINLESS STEEL	STAINLESS STEEL	STAINLESS STEEL	STAINLESS STEEL

Notes: Above materials are general, when ordered, Please contact NEWAY Sales or technical team to confirm the details.

Class 600 Cast Carbon Steel Gate Valve

ASME B16.34,
Pressure Seal, OS&Y, Rising Stem,
Non-rising Handwheel,
Flexible Wedge

Figure NO.:

G6R-PS,WCB/NO.5
G6B-PS,WCB/NO.5
G6J-PS,WCB/NO.5

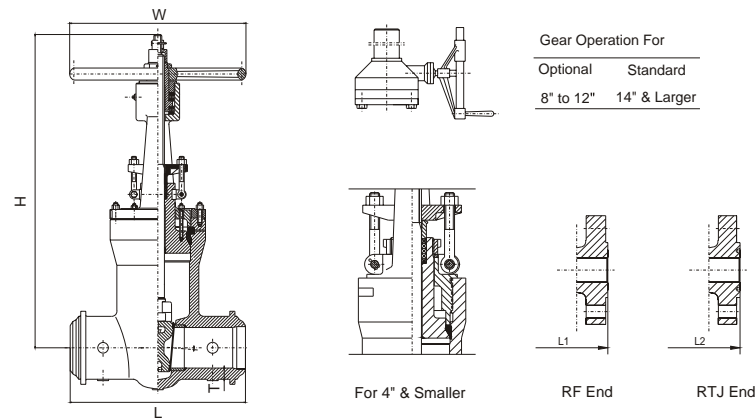

NPS	in	2"	2-1/2"	3"	4"	5"	6"	8"	10"	12"	14"	16"	18"	20"	24"	26"	28"	30"
DN	mm	50	65	80	100	125	150	200	250	300	350	400	450	500	600	650	700	750
L-L1 (RF-BW)	in	11.5	13	14	17	20	22	26	31	33	35	39	43	47	55	57	61	65
	mm	292	330	356	432	508	559	660	787	838	889	991	1092	1194	1397	1448	1549	1651
L2 (RTJ)	in	11.62	13.12	14.12	17.12	20.12	22.12	26.12	31.12	33.12	35.12	39.12	43.13	47.25	55.38	57.50	61.50	65.50
	mm	295	333	359	435	511	562	663	790	841	892	994	1095	1200	1407	1460.5	1562	1664
W	in	7.9	9.8	9.8	13.8	15.7	17.7	19.7	23.6	26.8	24	24	24	24	31.50	31.50	39.38	39.38
	mm	200	250	250	350	400	450	500	600	680	610	610	610	610	800	800	1000	1000
H	in	23.2	24.8	26.3	36	39.4	42.5	49.9	59.5	70.5	73.1	85.1	88.63	97.25	118.13	128	137.88	149
	mm	590	629	667	914	1000	1080	1267	1511	1791	1857	2162	2251	2470	3000	3251	3502	3785
WT(RF)	kg	70	95	100	148	208	245	320	430	515	670	905	1150	1445	2080	2445	2835	3250
WT(BW)	kg	62	80	84	115	150	171	215	268	318	435	570	720	890	1285	1510	1750	2010

Class 1500 Cast Carbon Steel Gate Valve

ASME B16.34,
Pressure Seal, OS&Y, Rising Stem,
Non-rising Handwheel,
Flexible Wedge

Figure NO.:

G15R-PS,WCB/NO.5
G15B-PS,WCB/NO.5
G15J-PS,WCB/NO.5

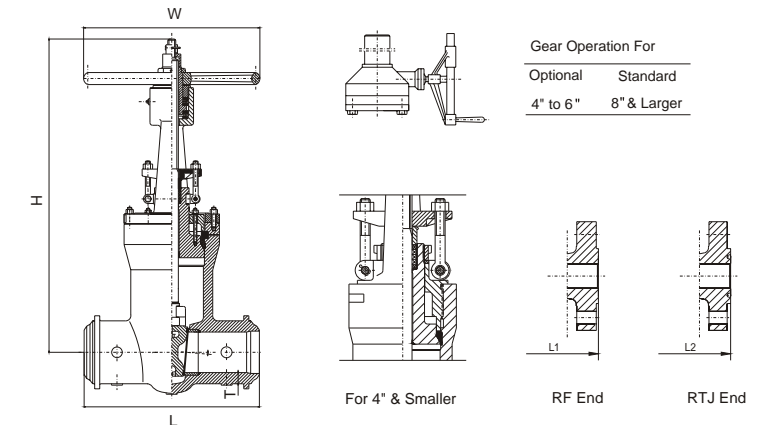

NPS	in	2"	2-1/2"	3"	4"	6"	8"	10"	12"	14"	16"	18"	20"	24"
DN	mm	50	65	80	100	150	200	250	300	350	400	450	500	600
L (BW)	in	8.5	10	12	16	22	28	34	39	42	47	53	58	66
	mm	216	254	305	406	559	711	864	991	1067	1194	1346	1473	1676
L1 (RF)	in	14.5	16.5	18.5	21.5	27.75	32.75	39	44.5	49.5	54.5	60.5	65.5	76.5
	mm	368	419	470	546	705	832	991	1130	1257	1384	1537	1664	1943
L2 (RTJ)	in	14.62	16.62	18.62	21.62	28	33.13	39.38	45.12	50.25	55.38	61.38	66.38	77.63
	mm	371	422	473	549	711	842	1000	1146	1276	1407	1559	1686	1972
W	in	10	12	14	20	24	18	18	24	24	24	39.38	47.25	35.5
	mm	250	300	350	500	600	458	458	610	610	610	1000	1200	900
H	in	23	30	30	34	39	53	58.3	73.6	87	92	111.13	122.13	148.25
	mm	594	753	756	864	994	1349	1480	1870	2216	2331	2823	3102	3766
WT(RF)	kg	63	99	126	218	504	956	1481	2184	2741	3780	5960	7370	10610
WT(BW)	kg	42	67	87	150	367	718	1071	1523	1890	2888	4630	5720	8240

Class 900 Cast Carbon Steel Gate Valve

ASME B16.34,
Pressure Seal, OS&Y, Rising Stem,
Non-rising Handwheel,
Flexible Wedge

Figure NO.:

G9R-PS,WCB/NO.5
G9B-PS,WCB/NO.5
G9J-PS,WCB/NO.5

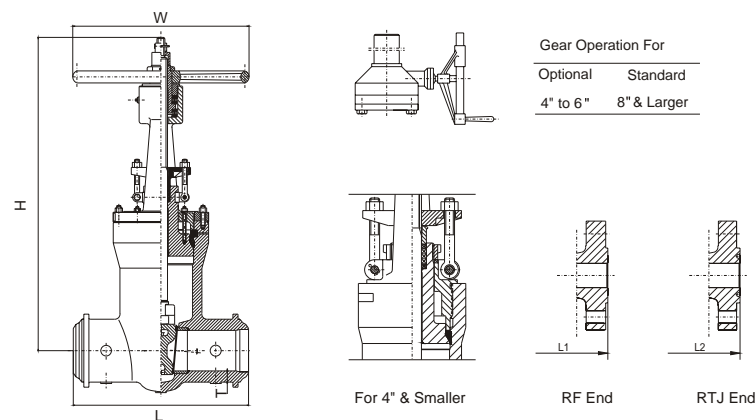

NPS	in	2"	2-1/2"	3"	4"	6"	8"	10"	12"	14"	16"	18"	20"	24"	26"	28"	30"
DN	mm	50	65	80	100	150	200	250	300	350	400	450	500	600	650	700	750
L (BW)	in	8.5	10	12	14	20	26	31	36	39	43	48	52	61	64.5	68	71.5
	mm	216	254	305	356	508	660	787	914	991	1092	1219	1321	1549	1638	1727	1816
L1 (RF)	in	14.5	16.5	15	18	24	29	33	38	40.5	44.5	48	52	61	-	-	-
	mm	368	419	381	457	610	737	838	965	1029	1130	1219	1321	1549	-	-	-
L2 (RTJ)	in	14.62	16.62	15.12	18.12	24.12	29.12	33.12	38.12	40.88	44.88	48.5	52.5	61.75	-	-	-
	mm	371	422	384	460	613	740	841	968	1038	1140	1232	1333	1568	-	-	-
W	in	10	10	12	14	20	24	24	24	24	30.5	30.5	39.38	39.38	39.38	47.25	
	mm	250	250	300	350	500	600	610	610	610	610	610	800	800	1000	1000	1200
H	in	23	30	30	34	40	50	61	70	80	89	97.25	108.25	127.62	138.25	149	159.5
	mm	594	753	756	864	1013	1276	1543	1781	2026	2261	2470	2750	3242	3512	3785	4051
WT(RF)	kg	63	99	107	158	294	693	1008	1418	1785	2520	3320	4400	6770	-	-	-
WT(BW)	kg	42	67	70	108	194	520	772	1103	1470	2048	2730	3685	5430	6370	7385	8480

Class 2500 Cast Carbon Steel Gate Valve

ASME B16.34,
Pressure Seal, OS&Y, Rising Stem,
Non-rising Handwheel,
Flexible Wedge

Figure NO.:

G25R-PS,WCB/NO.5
G25B-PS,WCB/NO.5
G25J-PS,WCB/NO.5

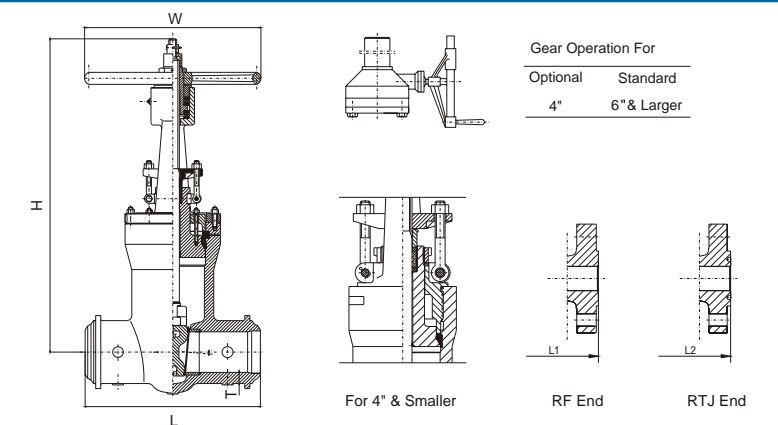

NPS	in	2"	2-1/2"	3"	4"	6"	8"	10"	12"	14"	16"	18"	20"	24"
DN	mm	50	65	80	100	150	200	250	300	350	400	450	500	600
L (BW)	in	11	13	14.5	18	24	30	36	41	44	49	55	61	68
	mm	279	330	368	457	610	762	914	1041	1118	1245	1397	1549	1727
L1 (RF)	in	17.75	20	22.75	26.5	36	40.25	50	56	-	-	-	-	-
	mm	451	508	578	673	914	1022	1270	1422	-	-	-	-	-
L2 (RTJ)	in	17.88	20.25	23	26.88	36.5	40.88	50.88	56.88	-	-	-	-	-
	mm	454	514	584	683	927	1038	1292	1445	-	-	-	-	-
W	in	14	18	18	20	24	24	24	24	24	24	31.5	31.5	39.38
	mm	350	450	450	500	610	610	610	610	610	610	800	800	1000
H	in	23	30	30	34	44	55	69	74	94.13	97.25	116.13	128.75	153.63
	mm	594	753	756	870	1129	1389	1748	1873	2291	2470	2950	3270	3902
WT(RF)	kg	89	142	173	346	851	1386	2493	3091	-	-	-	-	-
WT(BW)	kg	53	95	100	200	488	850	1680	2330	3400	4200	5000	6170	8880

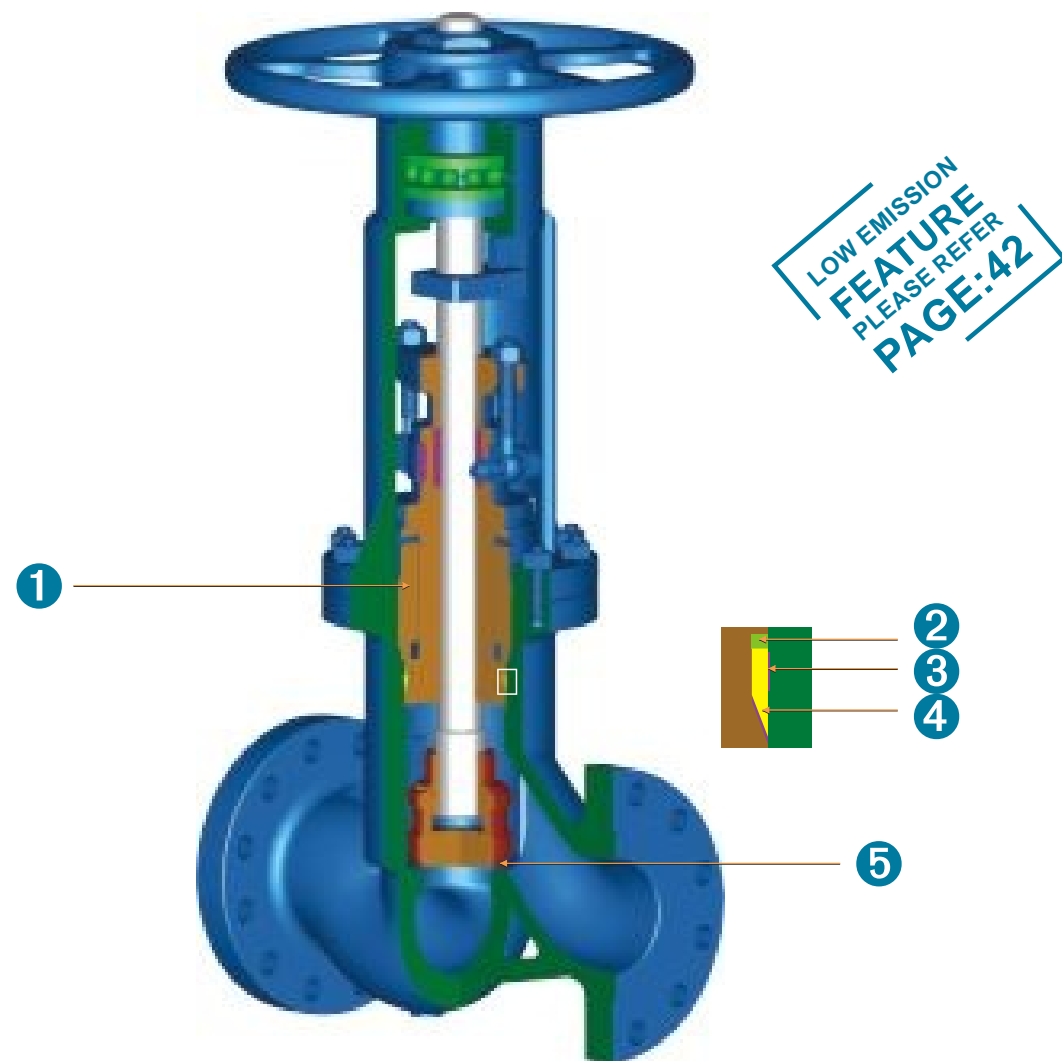

- 1 Thrust ring nut absorb all the thrust applied by the internal pressure.
- 2 Thrust ring to provide bearing surface and prevent deformation of the gaskets.
- 3 Stainless steel inlay to ensure soundness and corrosion-resistance in the vital body sealing zone for carbon and alloy steel valves.
- 4 Soft steel gasket seal to provide large contact area for perfect sealing.
- 5 Seat face with satellite 6 is standard design.

Part	Standard	Stainless Steel	High temperature Service		
			ASTM A217-WC6/STL.OVERLAY	ASTM A217-WC9/STL.OVERLAY	ASTM A217-C12A/STL.OVERLAY
BODY	ASTM A216-WCB/STL.OVERLAY	ASTM A351-CF8M/STL.OVERLAY	ASTM A217-WC6/STL.OVERLAY	ASTM A217-WC9/STL.OVERLAY	ASTM A217-C12A/STL.OVERLAY
BONNET	ASTM A105	ASTM A182-F316	ASTM A182-F11	ASTM A182-F22	ASTM A217-C12A
DISC	ASTM A182-F6a & ASTM A105/ER410	ASTM A182-F316	ASTM A182-F6a & ASTM A182-F11/ER410	ASTM A182-F6a & ASTM A182-F22/ER410	ASTM A182-F6a
STEM NUT	ASTM A439 D-2	ASTM A439 D-2	ASTM A439 D-2	ASTM A439 D-2	ASTM A439 D-2
GLAND FLANGE	ASTM A216-WCB	ASTM A351-CF8	ASTM A216-WCB	ASTM A216-WCB	ASTM A216-WCB
HANDWHEEL	DUCTILE IRON	DUCTILE IRON	DUCTILE IRON	DUCTILE IRON	DUCTILE IRON
BONNET SEAL RING	ASTM A182-F304(4"&Smaller GRAPHITE)	ASTM A182-F316L(4"&Smaller GRAPHITE)	ASTM A182-F304(4"&Smaller GRAPHITE)	ASTM A182-F304(4"&Smaller GRAPHITE)	ASTM A182-F304(4"&Smaller GRAPHITE)
STEM	ASTM A182-F6a	ASTM A182-F316	ASTM A182-F6a	ASTM A182-F6a	ASTM A182-F6a
RETAINING NUT FOR STEM NUT	CARBON STEEL	STAINLESS STEEL	CARBON STEEL	CARBON STEEL	CARBON STEEL
GLAND	ASTM A276-420	ASTM A182-F316	ASTM A276-420	ASTM A276-420	ASTM A276-420
HANDWHEEL NUT	CARBON STEEL	STAINLESS STEEL	CARBON STEEL	CARBON STEEL	CARBON STEEL
DISC NUT	ASTM A276-420	ASTM A182-F316	ASTM A276-420	ASTM A276-420	ASTM A276-420
STEM WASHER	ASTM A276-430	NO	ASTM A276-430	ASTM A276-430	ASTM A276-430
THRUST RING	CARBON STEEL	AITM A276-420	AISI 4140	AISI 4140	AISI 4140
PACKING	GRAPHITE	GRAPHITE	GRAPHITE	GRAPHITE	GRAPHITE
CLIPPING RING	ASTM A216-WCB	ASTM A351-CF8	ASTM A217-WC6	ASTM A217-WC6	ASTM A276-420
YOKE STUD	ASTM A193-B7	ASTM A193-B8	ASTM A193-B16	ASTM A193-B16	ASTM A193-B16
YOKE NUT	ASTM A194-2H	ASTM A194-8	ASTM A194-4	ASTM A194-4	ASTM A194-4
EYE BOLT	ASTM A193-B7	ASTM A193-B8	ASTM A193-B16	ASTM A193-B16	ASTM A193-B16
GLAND NUT	ASTM A194-2H	ASTM A194-8	ASTM A194-4	ASTM A194-4	ASTM A194-4
BONNET NUT 1	CARBON STEEL	ASTM A276-420	AISI 4140	AISI 4140	AISI 4140
CLIPPING RINGBOLT	CARBON STEEL	STAINLESS STEEL	STAINLESS STEEL	STAINLESS STEEL	STAINLESS STEEL
BONNET NUT 2	CARBON STEEL	ASTM A276-420	AISI 4140	AISI 4140	AISI 4140
ORIENTED BLOCK	CARBON STEEL	ASTM A276-420	CARBON STEEL	CARBON STEEL	CARBON STEEL
YOKE	ASTM A216-WCB	ASTM A351-CF8	ASTM A216-WCB& ASTM A217-WC6	ASTM A216-WCB& ASTM A217-WC6	ASTM A217-C12A
RIVET	CARBON STEEL	STAINLESS STEEL	CARBON STEEL	CARBON STEEL	STAINLESS STEEL
NAME PLATE	STAINLESS STEEL	STAINLESS STEEL	STAINLESS STEEL	STAINLESS STEEL	STAINLESS STEEL

Notes: Above materials are general, when ordered, Please contact NEWAY Sales or technical team to confirm the details.

Class 600 Cast Carbon Steel Globe Valve

ASME B16.34,
Pressure Seal, OS&Y,
Rising Stem and Handwheel,
Swivel Disc

Figure NO.:

GL6R-PS,WCB/NO.5
GL6B-PS,WCB/NO.5
GL6J-PS,WCB/NO.5

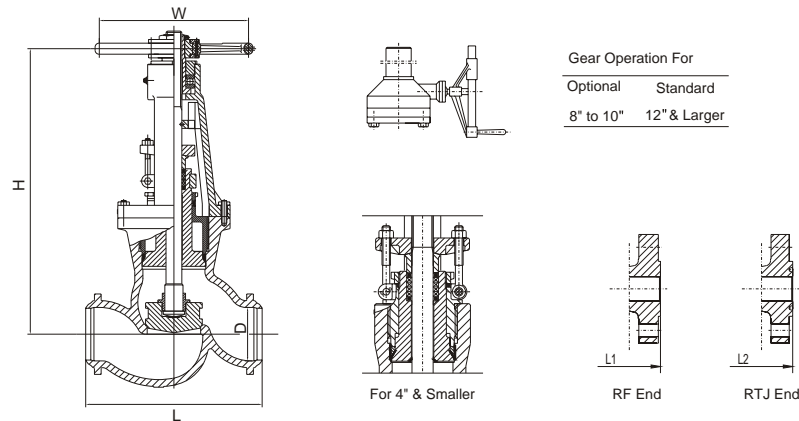

NPS	in	2"	2-1/2"	3"	4"	5"	6"	8"	10"	12"	14"	16"
DN	mm	50	65	80	100	125	150	200	250	300	350	400
L-L1 (RF-BW)	in	11.5	13	14	17	20	22	26	31	33	35	39
	mm	292	330	356	432	508	559	660	787	838	889	991
L2 (RTJ)	in	11.62	13.12	14.12	17.12	20.12	22.12	26.12	31.12	33.12	35.12	39.12
	mm	295	333	359	435	511	562	663	790	841	892	994
W	in	9.8	11.8	13.8	17.7	19.7	22	23.6	27.6	24	24	29.9
	mm	250	300	350	450	500	560	600	700	610	610	760
H	in	21.7	24.8	26.8	29.5	39.4	45.3	49.2	55.1	61	70.9	85
	mm	550	630	680	750	1000	1150	1250	1400	1550	1800	2160
WT(RF)	kg	45	55	85	135	190	305	620	1310	1900	2720	3150
WT(BW)	kg	35	45	60	95	150	230	540	1150	1720	2530	2900

Class 1500 Cast Carbon Steel Globe Valve

ASME B16.34,
Pressure Seal, OS&Y,
Rising Stem and Handwheel,
Swivel Disc

Figure NO.:

GL15R-PS,WCB/NO.5
GL15B-PS,WCB/NO.5
GL15J-PS,WCB/NO.5

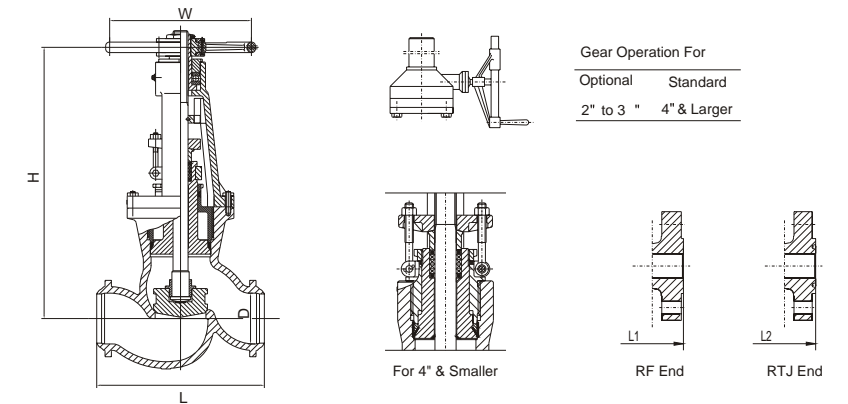

NPS	in	2"	2-1/2"	3"	4"	6"	8"	10"	12"	14"
DN	mm	50	65	80	100	150	200	250	300	350
L-L1 (RF-BW)	in	14.5	16.5	18.5	21.5	27.75	32.75	39	44.5	49.5
	mm	368	419	470	546	705	832	991	1130	1257
L2 (RTJ)	in	14.62	16.62	18.62	21.62	28	33.13	39.38	45.13	50.25
	mm	371	422	473	549	711	842	1000	1146	1276
W	in	14	14	20	22	24	24	39.38	39.38	47.25
	mm	350	350	500	560	610	610	1000	1000	1200
H	in	24.4	25.2	32.9	33.7	48.4	70.9	78.78	91	106
	mm	619	641	835	857	1230	1800	2000	2311	2692
WT(RF)	kg	84	116	143	236	918	1764	2680	3400	4300
WT(BW)	kg	58	62	128	168	781	1502	2280	2830	3600

Class 900 Cast Carbon Steel Globe Valve

ASME B16.34,
Pressure Seal, OS&Y,
Rising Stem and Handwheel,
Swivel Disc

Figure NO.:

GL9R-PS,WCB/NO.5
GL9B-PS,WCB/NO.5
GL9J-PS,WCB/NO.5

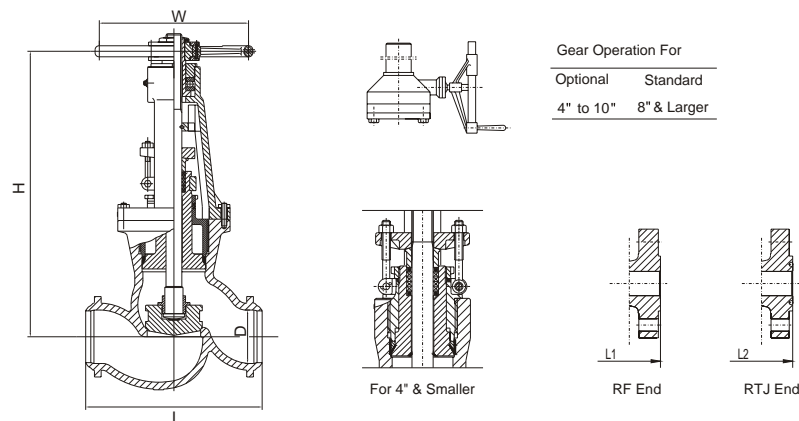

NPS	in	2"	2-1/2"	3"	4"	6"	8"	10"	12"	14"	16"
DN	mm	50	65	80	100	150	200	250	300	350	400
L-L1 (RF-BW)	in	14.5	16.5	15	18	24	29	33	38	40.50	44.50
	mm	368	419	381	457	610	737	838	965	1029	1130
L2 (RTJ)	in	14.62	16.62	15.12	18.12	24.12	29.12	33.13	38.13	40.88	44.88
	mm	371	422	384	460	613	740	841	968	1038	1140
W	in	14	14	18	20	24	24	24	39.38	39.38	47.25
	mm	350	350	450	500	610	610	610	1000	1000	1200
H	in	24.4	25.2	28.4	33.5	48.2	53.1	61	68.88	78.75	91
	mm	619	641	721	850	1225	1350	1550	1750	2000	2310
WT(RF)	kg	84	110	116	179	441	1050	1720	2300	3350	4000
WT(BW)	kg	58	74	84	137	378	945	1520	2050	3050	3600

Class 2500 Cast Carbon Steel Globe Valve

ASME B16.34,
Pressure Seal, OS&Y,
Rising Stem and Handwheel,
Swivel Disc

Figure NO.:

GL25R-PS,WCB/NO.5
GL25B-PS,WCB/NO.5
GL25J-PS,WCB/NO.5

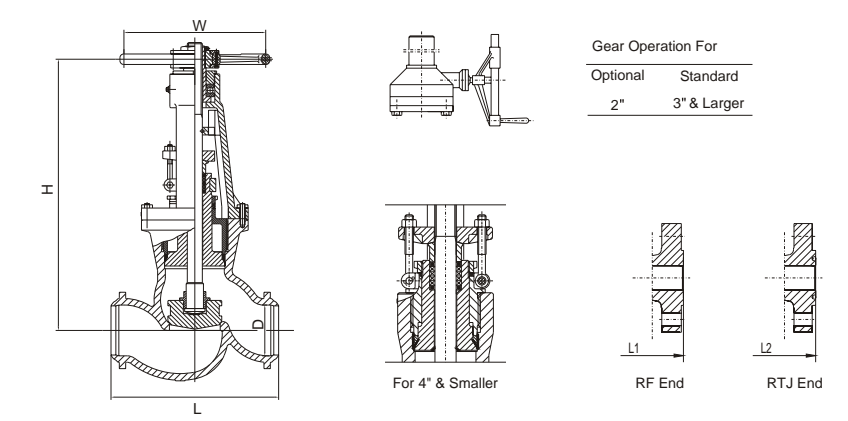

NPS	in	2"	2-1/2"	3"	4"	6"	8"	10"	12"
DN	mm	50	65	80	100	150	200	250	300
L-L1 (RF-BW)	in	17.75	20	22.75	26.5	36	40.25	50	56
	mm	451	508	578	673	914	1022	1270	1422
L2 (RTJ)	in	17.88	20.25	23	26.88	36.5	40.88	50.88	56.88
	mm	454	541	584	683	927	1038	1292	1445
W	in	16	20	22	24	24	24	39.38	39.38
	mm	400	500	560	610	610	610	1000	1000
H	in	24.3	30.7	31.5	51.2	53.9	85	100	106
	mm	616	781	800	1300	1370	2160	2540	2692
WT(RF)	kg	105	163	221	525	1313	2520	3300	4200
WT(BW)	kg	74	116	147	368	973	2100	2500	3300

LOW EMISSION
FEATURE
PLEASE REFER
PAGE:42

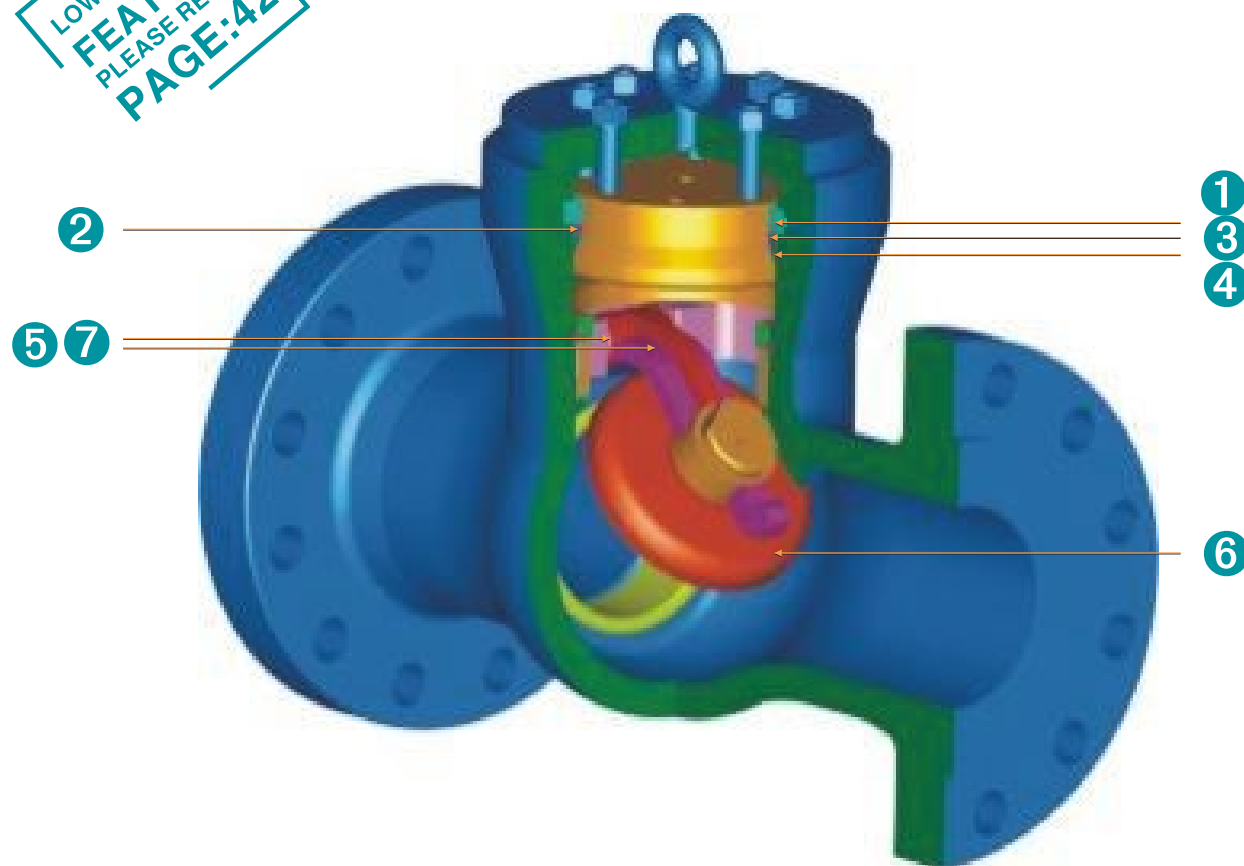

- 1 Segmental thrust ring absorb all the thrust applied by the internal pressure.
- 2 Thrust ring to provide bearing surface and prevent deformation of the gaskets.
- 3 Soft steel gasket seal to provide large contact area for perfect sealing.
- 4 Stainless steel inlay to ensure soundness and corrosion-resistance in the vital body sealing zone for carbon and alloy steel valves.
- 5 No external leakage hinge pin design.
- 6 Standard swing type disc only used in horizontal pipe lines handling liquids.
- 7 A hinge and hinge pin provided and mounted so as to permit full movement of the disc.

Part	Standard	Stainless Steel	High temperature Service		
			ASTM A217-WC6	ASTM A217-WC9	ASTM A217-C12A
BODY	ASTM A216-WCB	ASTM A351-CF8M	ASTM A217-WC6	ASTM A217-WC9	ASTM A217-C12A
COVER	ASTM A216-WCB(4"&Smaller ASTM A105)	ASTM A351-CF8M(4"&Smaller ASTM A182-F316)	ASTM A217-WC6(4"&Smaller ASTM A182-F11)	ASTM A217-WC9(4"&Smaller ASTM A182-F22)	ASTM A217-C12A(4"&Smaller ASTM A182-F91)
DISC	ASTM A217-CA15 &ASTM A216-WCB/ER410	ASTM A351-CF8M/STL.OVERLAY	ASTM A217-CA15 &ASTM A217-WC6/ER410	ASTM A217-CA15 &ASTM A217-WC9/ER410	ASTM A217-CA15
HINGE	ASTM A105	ASTM A351-CF8M	ASTM A217-WC6	ASTM A217-WC9	ASTM A217-C12A
HINGE PIN	ASTM A182-F6a	ASTM A276-316	ASTM A182-F6a	ASTM A182-F6a	ASTM A182-F6a
DISC NUT	ASTM A276-420	ASTM A276-316	ASTM A276-420	ASTM A276-420	ASTM A276-420
BONNET SEAL RING	ASTM A182-F304(4"&Smaller GRAPHITE)	ASTM A182-F316L(4"&Smaller GRAPHITE)	ASTM A182-F304(4"&Smaller GRAPHITE)	ASTM A182-F304(4"&Smaller GRAPHITE)	ASTM A182-F304(4"&Smaller GRAPHITE)
HOOK SCREW	CARBON STEEL	STAINLESS STEEL	CARBON STEEL	CARBON STEEL	CARBON STEEL
COVER STUD	ASTM A193-B7	ASTM A193-B8	ASTM A193-B16	ASTM A193-B16	ASTM A193-B16
COVER NUT	ASTM A194-2H	ASTM A194-8	ASTM A194-4	ASTM A194-4	ASTM A194-4
SEAT RING	ASTM A105/STL.OVERLAY	ASTM A182-F316/STL.OVERLAY	ASTM A182-F11/STL.OVERLAY	ASTM A182-F22/STL.OVERLAY	ASTM A182-F6a/STL.OVERLAY
SEPARATE RING COVER	CARBON STEEL	ASTM A276-420	AISI 4140	AISI 4140	AISI 4140
THRUST RING COVER	CARBON STEEL	ASTM A276-420	AISI 4140	AISI 4140	AISI 4140
SUPPORTING COVER	ASTM A105	ASTM A276-420	AISI 4140	AISI 4140	AISI 4140
STOP RING	ASTM A276-420	ASTM A276-316	ASTM A276-420	ASTM A276-420	ASTM A276-420
YOKE	ASTM A216-WCB	ASTM A276-316	ASTM A216-WCB& ASTM A217-WC6	ASTM A216-WCB& ASTM A217-WC6	ASTM A217-C12A
SEPARATE RING FOR STOP RING	ASTM A276-420	ASTM A276-316	ASTM A276-420	ASTM A276-420	ASTM A276-420
SPLIT PIN	STAINLESS STEEL	STAINLESS STEEL	STAINLESS STEEL	STAINLESS STEEL	STAINLESS STEEL
STOP RING SCREW	STAINLESS STEEL	STAINLESS STEEL	STAINLESS STEEL	STAINLESS STEEL	STAINLESS STEEL
RIVET	CARBON STEEL	STAINLESS STEEL	CARBON STEEL	CARBON STEEL	STAINLESS STEEL
NAME PLATE	STAINLESS STEEL	STAINLESS STEEL	STAINLESS STEEL	STAINLESS STEEL	STAINLESS STEEL

Notes: Above materials are general, when ordered, Please contact NEWAY Sales or technical team to confirm the details.

Class 600 Cast Carbon Steel Check Valve

ASME B16.34,
Pressure Seal, Swing Type Disc

Figure NO.:

S6R-PS,WCB/NO.5
S6B-PS,WCB/NO.5
S6J-PS,WCB/NO.5

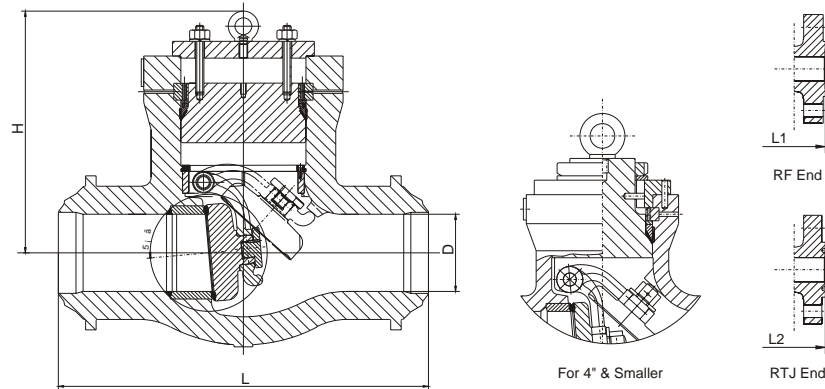

NPS	in	2"	2-1/2"	3"	4"	5"	6"	8"	10"	12"	14"	16"	18"	20"	24"	26"	28"	30"
DN	mm	50	65	80	100	125	150	200	250	300	350	400	450	500	600	650	700	750
L (RF-BW)	in	11.5	13	14	17	20	22	26	31	33	35	39	43	47	55	57	63	65
	mm	292	330	356	432	508	559	660	787	838	889	991	1092	1194	1397	1448	1600	1651
L2 (RTJ)	in	11.62	13.12	14.12	17.12	20.12	22.12	26.12	31.12	33.12	35.12	39.12	43.13	47.25	55.38	57.5	63.5	65.5
	mm	295	333	359	435	511	562	663	790	841	892	994	1095	1200	1407	1461	1613	1664
H	in	9.5	10.4	10.6	12.5	15.7	15.7	23.1	23.9	27.4	29.5	28.7	28.75	32.25	37.38	39.38	43.25	47.25
	mm	241	264	270	318	400	400	587	606	695	749	730	730	819	949	1000	1099	1200
WT(RF)	kg	27	35	45	85	135	190	350	500	670	880	1150	1480	1880	2600	3100	3500	4000
WT(BW)	kg	18	25	32	55	85	130	260	370	490	660	850	1100	1490	2040	2500	2800	3150

Class 1500 Cast Carbon Steel Check Valve

ASME B16.34,
Pressure Seal, Swing Type Disc

Figure NO.:

S15R-PS,WCB/NO.5
S15B-PS,WCB/NO.5
S15J-PS,WCB/NO.5

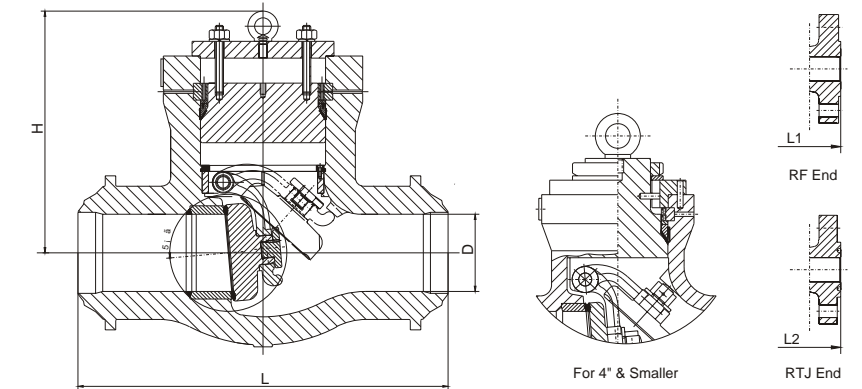

NPS	in	2"	2-1/2"	3"	4"	6"	8"	10"	12"	14"	16"	18"	20"	24"
DN	mm	50	65	80	100	150	200	250	300	350	400	450	500	600
L (BW)	in	8.5	10	12	16	22	28	34	39	42	47	60.5	65.5	76.5
	mm	216	254	305	406	559	711	864	991	1067	1194	1537	1664	1943
L1 (RF)	in	14.5	16.5	18.5	21.5	27.8	32.8	39	44.5	49.5	54.4	60.5	65.5	76.5
	mm	368	419	470	546	705	832	991	1130	1257	1384	1537	1664	1943
L2 (RTJ)	in	14.6	16.6	18.6	21.6	28	33.1	39.4	45.1	50.3	55.4	61.38	66.38	77.63
	mm	371	422	473	549	711	842	1000	1146	1276	1407	1559	1686	1972
H	in	9.5	10.4	10.8	12.5	16.6	18.9	23.3	25.4	28	29.5	34.63	37.38	43.25
	mm	241	264	274	318	422	479	591	645	711	749	880	949	1099
WT(RF)	kg	42	58	105	147	360	641	1103	1628	2205	2730	3300	4200	6000
WT(BW)	kg	21	34	42	74	233	504	777	1155	1481	1680	2100	2600	3500

Class 900 Cast Carbon Steel Check Valve

ASME B16.34,
Pressure Seal, Swing Type Disc

Figure NO.:

S9R-PS,WCB/NO.5
S9B-PS,WCB/NO.5
S9J-PS,WCB/NO.5

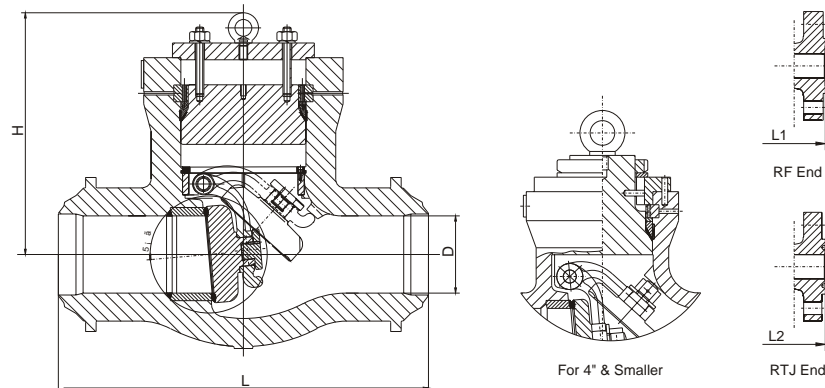

NPS	in	2"	2-1/2"	3"	4"	6"	8"	10"	12"	14"	16"	18"	20"	24"	26"	28"	30"
DN	mm	50	65	80	100	150	200	250	300	350	400	450	500	600	650	700	750
L (BW)	in	8.5	10	12	14	20	26	31	36	39	43	48	52	61	63	67	71
	mm	216	254	305	356	508	660	787	914	991	1092	1219	1321	1549	1600	1702	1803
L1 (RF)	in	14.5	16.5	15	18	24	29	33	38	40.5	44.5	48	52	61	65	69	73
	mm	368	419	381	457	610	737	838	965	1029	1130	1219	1321	1549	1651	1753	1854
L2 (RTJ)	in	14.6	16.1	15.1	18.1	24.1	29.1	33.1	38.1	40.9	44.9	48.5	52.5	61.75	65.88	69.88	73.88
	mm	371	422	384	460	613	740	841	968	1038	1140	1232	1333	1568	1673	1775	1876
H	in	9.5	10.4	10.6	12.5	15.7	23.1	23.9	27.4	29.5	28.7	33.50	34	37.75	39.38	45.25	55.13
	mm	241	264	270	318	400	587	606	695	749	730	851	864	959	1000	1149	1400
WT(RF)	kg	42	55	58	110	242	599	893	1365	1628	1733	2300	3000	4100	4600	5200	6000
WT(BW)	kg	21	32	34	68	168	462	725	1071	1281	1418	1850	2400	2900	3600	4000	4600

Class 2500 Cast Carbon Steel Check Valve

ASME B16.34,
Pressure Seal, Swing Type Disc

Figure NO.:

S25R-PS,WCB/NO.5
S25B-PS,WCB/NO.5
S25J-PS,WCB/NO.5

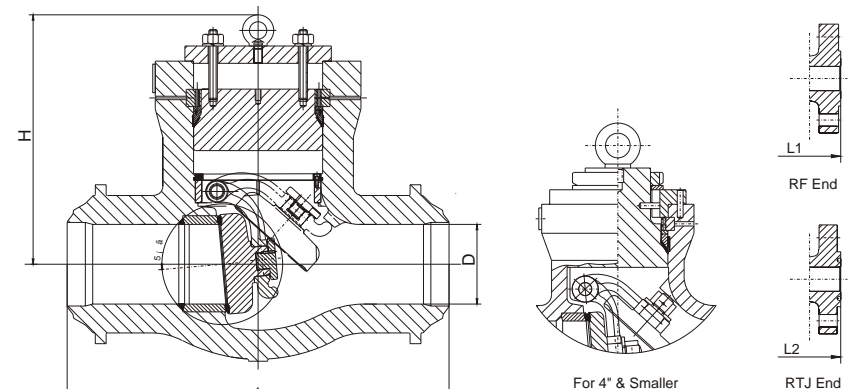

NPS	in	2"	2-1/2"	3"	4"	6"	8"	10"	12"	14"	16"	18"	20"	24"
DN	mm	50	65	80	100	150	200	250	300	350	400	450	500	600
L (BW)	in	11	13	14.5	18	24	30	36	41	44	49	55	61	68
	mm	279	330	368	457	610	762	914	1041	1118	1245	1397	1549	1727
L1 (RF)	in	17.8	20	22.8	26.5	36	40.3	50	56	-	-	-	-	-
	mm	451	508	578	673	914	1022	1270	1422	-	-	-	-	-
L2 (RTJ)	in	17.9	20.3	23	26.9	36.5	40.9	50.9	56.9	60.88	-	-	-	-
	mm	454	514	584	683	927	1038	1292	1445	1546	-	-	-	-
H	in	9.6	10.4	10.6	12.5	17.8	22	22.7	25.8	33.88	35.38	39.38	45.25	55.13
	mm	245	264	270	318	451	559	576	656	860	899	1000	1149	1400
WT(RF)	kg	89	124	163	299	588	1071	1676	2772	3350	-	-	-	-
WT(BW)	kg	53	74	89	142	285	598	783	1512	2450	3200	4050	5000	7200

Torque & Thrust

Gate Valve

Class	Size	20"					22"					24"					26"					28"					30"				
150	Pressure Rating	0.2MPa	0.5MPa	1MPa	1.5MPa	2MPa	0.2MPa	0.5MPa	1MPa	1.5MPa	2MPa	0.2MPa	0.5MPa	1MPa	1.5MPa	2MPa	0.2MPa	0.5MPa	1MPa	1.5MPa	2MPa	0.2MPa	0.5MPa	1MPa	1.5MPa	2MPa	0.2MPa	0.5MPa	1MPa	1.5MPa	2MPa
	Number of Turns	81					74					80					88					93									
	Thrust (KN)	61.08	65.64	86.24	118.99	151.74	69.52	74.36	101.53	141.33	181.13	55.56	61.49	95.29	142.93	190.57	80.76	87.06	123.44	172.19	220.95	75.55	81.59	126.26	182.9	239.55	95.07	101.64	158.13	223.24	288.35
	Torque (N*M)	278.2	298.9	392.7	541.9	691	350.3	374.7	511.6	712.1	912.6	293.2	324.5	502.8	754.2	1005.7	464.7	501	710.3	990.9	1271.4	434.4	469.5	726.5	1052.5	1378.5	592.4	633.4	985.4	1391.1	1796.9
300	Pressure Rating	1MPa	2MPa	3MPa	4MPa	5.1MPa	1MPa	2MPa	3MPa	4MPa	5.1MPa	1MPa	2MPa	3MPa	4MPa	5.1MPa	1MPa	2MPa	3MPa	4MPa	5.1MPa	1MPa	2MPa	3MPa	4MPa	5.1MPa	1MPa	2MPa	3MPa	4MPa	5.1MPa
	Number of Turns	61					65					79					87					61									
	Thrust (KN)	86.21	150.48	214.75	279.02	349.7						107.31	188.7	270.09	351.48	441.01	124.45	220.98	317.51	414.04	520.22	140.25	252.59	364.93	477.26	600.83	50.52	60.62	70.72	80.82	91.94
	Torque (N*M)	434.3	758.2	1082	1405.8	1762						617.5	1085.9	1544.2	2022.6	2537.7	775.5	1377	1978.5	2580.1	3241.8	874	1574	2274	2974.1	3744.1	1423.1	2413.7	3404.2	4394.8	5484.4
600	Pressure Rating	3MPa	5MPa	6.5MPa	8MPa	10.2MPa	3MPa	5MPa	6.5MPa	8MPa	10.2MPa	3MPa	5MPa	6.5MPa	8MPa	10.2MPa	3MPa	5MPa	6.5MPa	8MPa	10.2MPa	3MPa	5MPa	6.5MPa	8MPa	10.2MPa	3MPa	5MPa	6.5MPa	8MPa	10.2MPa
	Number of Turns	59					46					54					57														
	Thrust (KN)	195.85	303.16	383.64	464.11	582.15						253.88	408.17	523.88	639.59	809.31						385.79	595.75	753.21	910.68	1141.64	430.63	670.49	850.38	1030.27	1294.12
	Torque (N*M)	1220.4	1889.1	2390.6	2892.1	3627.7						1827.6	2938.2	3771.2	4604.1	5825.8						3329.7	5141.8	6500.9	7860	9853.4	3716.7	5786.9	7339.5	8892.2	4169.4
900	Pressure Rating	5MPa	8MPa	10MPa	13MPa	15.3MPa	5MPa	8MPa	10MPa	13MPa	15.3MPa	5MPa	8MPa	10MPa	13MPa	15.3MPa	5MPa	8MPa	10MPa	13MPa	15.3MPa	5MPa	8MPa	10MPa	13MPa	15.3MPa	5MPa	8MPa	10MPa	13MPa	15.3MPa
	Number of Turns																54					57									
	Thrust (KN)	332.68	491.07	596.66	755.05	876.48						467.56	690.11	838.47	1061.02	1231.64															
	Torque (N*M)	2553.7	3769.5	4580.1	5795.9	6728						3812.3	5626.9	6836.6	8651.1	10042.3															
1500	Pressure Rating	5MPa	10MPa	15MPa	20MPa	25.5MPa	5MPa	10MPa	15MPa	20MPa	25.5MPa	5MPa	10MPa	15MPa	20MPa	25.5MPa	5MPa	10MPa	15MPa	20MPa	25.5MPa	5MPa	10MPa	15MPa	20MPa	25.5MPa	5MPa	10MPa	15MPa	20MPa	25.5MPa
	Number of Turns																														
	Thrust (KN)	394.53	651.25	907.97	1164.7	1447.09						534.15	905.44	1276.72	1648	2056.41															
	Torque (N*M)	3593.4	5931.6	8269.9	10608.1	13180.1						5884.1	9974	14063.9	18153.8	22652.7															
2500	Pressure Rating																														
	Number of Turns																														
	Thrust (KN)																														
	Torque (N*M)																														
Class	Size	32"					34"					36"																			
150	Pressure Rating	0.2MPa	0.5MPa	1MPa	1.5MPa	2MPa	0.2MPa	0.5MPa	1MPa	1.5MPa	2MPa	0.2MPa	0.5MPa	1MPa	1.5MPa	2MPa															
	Number of Turns	97					72																								
	Thrust (KN)	98.39	105.23	171.05	242.62	314.18	112.5	120.4	196.87	278.47	360.07	122.12	131.18	216.95	307.47	397.98															
	Torque (N*M)	613.1	655.7	1065.9	1511.9	1957.8	782.9	838.2	1370.1	1938	2505.9	879.1	944.3	1561.7	2213.3	2864.9															
300	Pressure Rating	1MPa	2MPa	3MPa	4MPa	5.1MPa	1MPa	2MPa	3MPa	4MPa	5.1MPa	1MPa	2MPa	3MPa	4MPa	5.1MPa															
	Number of Turns																														
	Thrust (KN)	184.35	330.54	476.73	622.92	783.72						236.98	420.26	603.54	786.82	988.44															
	Torque (N*M)	1415.1	2537.3	3659.5	4781.6	6016						1932.2	3426.6	4921.1	6415.5	8059.3															
600	Pressure Rating	3MPa	5MPa	6.5MPa	8MPa	10.2MPa	3MPa	5MPa	6.5MPa	8MPa	10.2MPa	3MPa	5MPa	6.5MPa	8MPa	10.2MPa															
	Number of Turns						65					69																			
	Thrust (KN)						540.59	846.3	1075.58	1304.86	1641.14																				
	Torque (N*M)						4932.7	7708.1	9796.4	11884.7	14947.6																				
900	Pressure Rating	5MPa	8MPa	10MPa	13MPa	15.3MPa	5MPa	8MPa	10MPa	13MPa	15.3MPa	5MPa	8MPa	10MPa	13MPa	15.3MPa															
	Number of Turns						65					69																			
	Thrust (KN)																														
	Torque (N*M)																														
Class	Size	40"					42"					48"					52"														
150	Pressure Rating	0.2MPa	0.5MPa	1MPa	1.5MPa	2MPa	0.2MPa	0.5MPa	1MPa	1.5MPa	2MPa	0.2MPa	0.5MPa	1MPa	1.5MPa	2MPa	0.2MPa	0.5MPa	1MPa	1.5MPa	2MPa										
	Number of Turns	79					82					101																			
	Thrust (KN)	136.94	149.91	261.66	373.4	485.15	162.02	176.29	298.89	421.48	554.08	191.43	216.58	376.48	536.39	696.28	216.73	255.45	445.27	635.09	824.92										
	Torque (N*M)	1051.2	1150.8	2008.5	2866.3	3724.1	1321	1437.4	2437	3436.6	4436.2	1652.2	1869.3	3249.3	4629.4	6009.5	1973.9	2326.6	4055.6	5784.5	7513.4										

Note: 1. All above data are based on Single Head thread.
 2. Torques shown in these tables are to be used as a guide for actuator selection. A safety factor of 1.25 - 1.5 is recommended for actuator sizing.

SZ Series for Gate & Globe Valves

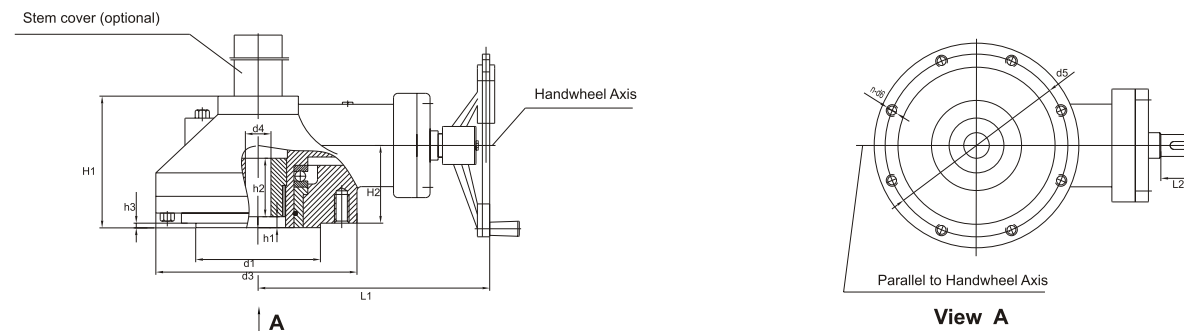

SZ-Y Series for Globe Valves

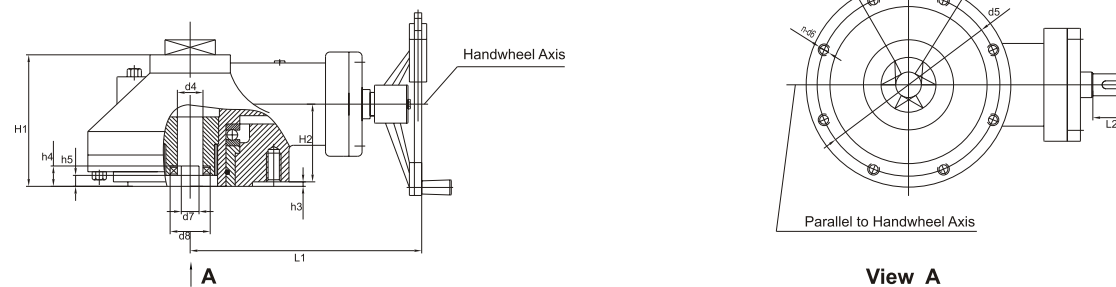

With the enhancement of people ecological awareness since 1960's, especially under the background of nowadays quick economic globalization, protecting environment is becoming common understanding in present global development, whether developed or developing countries, and had led to born associated law and regulation in different fields, including modern process industries.

Industrial valves are one of main pollution sources in modern process industries because of fugitive emission. To minimize the risk of process media leaked through valves to human health, safety and environment, Neway developed low emission technology for all series valves, which featured the essential function of controlling effectively the fugitive emission leakage of various media from valves in virtue of emission defense material using and special structure design, and these valves are measured and tested in accordance with ISO 15848 or Shell SPE 77/312.



Design Features

Emission Defense Packing

The serial Neway packing set consist of 3 die formed flexible graphite rings and 2 braided flexible graphite rings with cone surface. The graphite packing sets feature pliability, well compression recovery, heat resistance, less stress relaxation and low creep. The structure allows a low friction on rotary & rising stem valves so as to provide the stabilized seal performance for long cycle life.

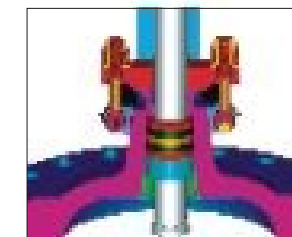

Stuffing box and stem finish

All of the valves have been design to have maximum Ra1.6 inside surface of stuffing box, a reasonable rougher surface finish will allow better holding of the packing ring and results in a better sealing performance. The stem surface finish is controlled to a maximum Ra0.4, and straightness and roundness are precision controlled in accordance with Neway design and manufacturing standard. The structure will ensure the graphite to fill and migrate into the stem micro scratches, and function as a lubricant to reduce leakage through stem.

Fugitive Emission Valve Test

Neway full series low emission gate, globe and check valves had been Certified as per TA-Luft, the proto type test and the product test are carried out and inspected by a third part at NewayChina plant in year 2003. Below table shown the typical test parameter:

Test Standard	ISO 15848	Neway Acceptable Level	
		Test Medium	Test Pressure
Test Standard	ISO 15848	Stem Seal Leakage Rate	ISO 15848 class B 1.78x10 ⁻⁷ Pa.m ³ /s (Per mm Stem diameter)
Test Medium	97% Helium	Mechanical Cycles	100
Test Pressure	Valve body pressure At the selected test Temperature as ASME B16.34	Temperature	-196 ~ 450C
Test Equipment	Helium Spectrometer		

Optional Live-loaded Gland Bolts

Live-loaded gland bolts is optional on customer request. The special structure can maintain a permanent packing stress in virtue of two sets of Belleville spring, and extend the low emission service life. Neway standard Belleville springs are protected by a weatherproof cap to keep them from environmental contamination so as to ensure a long and continual stable work life.

1.Main Material:

Name of parts	Housing	Bevel gear	Output shaft	Stem nut
Material	ASTM A216-WCB	AISI 1045 & 5140	AISI 1045	ASTM A439-D2
Material	ASTM A352-LCB	AISI 1045 & 5140	AISI 1045	ASTM A439-D2

2.Technical Parameters:

Item	Type								
	SZ000	SZ00	SZ0	SZ1	SZ2	SZX3	SZX4	SZX5	SZX6
Allowable torque(N.m)	200	400	750	1500	3000	6000(9000)	10000(15000)	22100	32000
Allowable thrust(KN)	40	100	150	200	350	840	1400	2400	2745
Reduction ratio	4:1	3:1	3:1	4.1:1	6:1	58:1(86:1)	86:1(104:1)	104:1(128:1)	125:1
Allowable stem diameter(mm)	25	42	55	62	75	115	125	125	150
Handwheel diameter(mm)	305	305	305	460	610	810	1000	1200	1200

Note: "X"SZX4,SZX3 indicates that a planetary gear reduction drive is used .
The allowable torque and the ratio parameter in the brackets will
Chose by the manufacturer's option

3.Flange Type and Dimensions (mm)

Code Type	L1	L2	H1	H2	d1	d2	d3	d4(max)	d5	n-d6	d7	d8	h1	h2	h3	h4	h5	Flange type
SZ000	200	45	100	59	70(f8)		146	25	102	4-M10	40	51	1	42	3	8	4	F10
SZ00	210	60	122	76	100(f8)		178	42	140	4-M16	50	64.5	1	60	4	10	5	F14
SZ0	232	60	135	84	130(f8)		210	55	165	4-M20	63	79	1	70	5	15	5	F16
SZ1	283	60	160	95	200(f8)		289	62	254	8-M16	70	89	1	75	5	15	5	F25
SZ2	370	60	220	140	230(f8)		346	75	298	8-M20	95	119	15	110	5	18	5	F30
SZX3	610	60	330	328	260(f8)	428	510	115	356	8-M30	128	166	30	168	5	18	5	F35
SZX4	668	110	360	410	300(f8)	475	620	125	406	8-M36	138	188	35	180	8	25	5	F40
SZX5	668	110	360	410	370	544	690	125	483	12-M36	150	210	35	180	8	32	5	F48
SZX6	1020	60	500	282	470	686	810	150	603	20-M36	178	240	40	230	8	40	5	F60

For servicing H₂S-containing environments in oil and gas production, Neway offer Nace valve made of the component metal materials specially heat-treated and hardness-controlled in compliance with NACE standard MR0175, so as to resist all

mechanisms of cracking that can be caused by H₂S, including sulfide stress cracking (SSC), stress corrosion cracking (SCC), and other hydrogen-induced cracking. Below table show typical Nace material configuration for Neway cast steel gate valves:

NACE Valves Compared to API 600 Valves

Valve Parts	ASTM Specification	API 600 Valves	NACE Valves
Body/Bonnet	A216 Gr. WCB	≤ 22HRC	≤ 22HRC
Wedge	A216 Gr. WCB or A217 CA15	Quenching + High Temperature Tempering 25-30HRC	Quenching + Double Tempering ≤ 22HRC
Seat Ring	A105 + Stellite 6 Overlayed	Stress Relieving Tempering Overlay hardness ≥ 38HRC	Stress Relieving Tempering Overlay hardness ≥ 38HRC
Stem	A182 F6a	Quenching + High Temperature Tempering 17-22HRC	Quenching + Double Tempering ≤ 22HRC
Gland	ANSI 420	Quenching + High Temperature Tempering 31-35HRC	Quenching + Double Tempering ≤ 22HRC
Backseat Bushing	ANSI 420	Quenching + High Temperature Tempering 31-35HRC	Quenching + Double Tempering ≤ 22HRC
Body/Bonnet Studs		ASTM A193 Grade B7	ASTM A193 Grade B7M
Body/Bonnet Nuts		ASTM A194 Grade 2H	ASTM A194 Grade 2HM

Special Design Feature

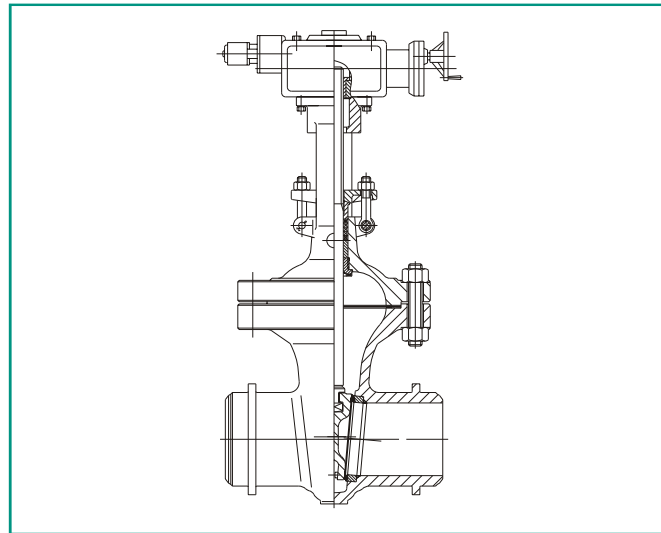

All gate and globe valves can be equipped with electric , Pneumatic or hydraulic actuator, per customer's specification.

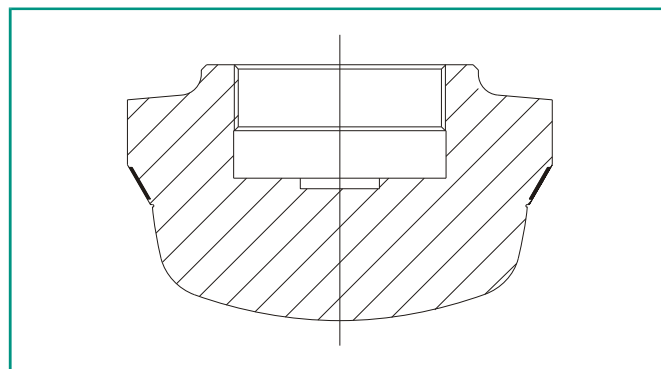

Parabola disc

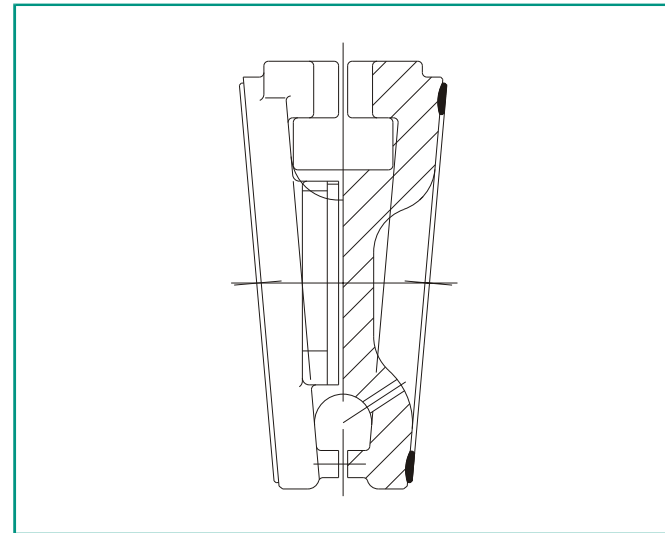

Relief provision

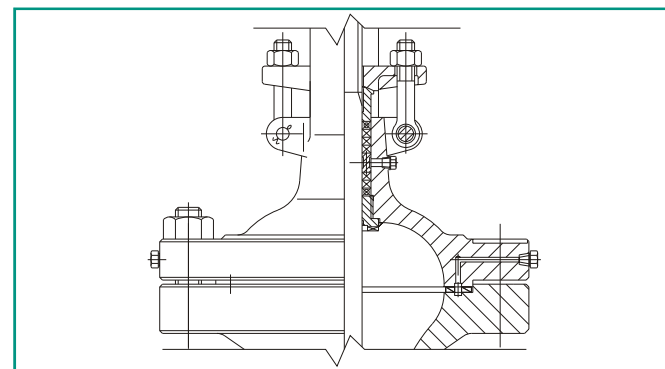

Leak-off detect

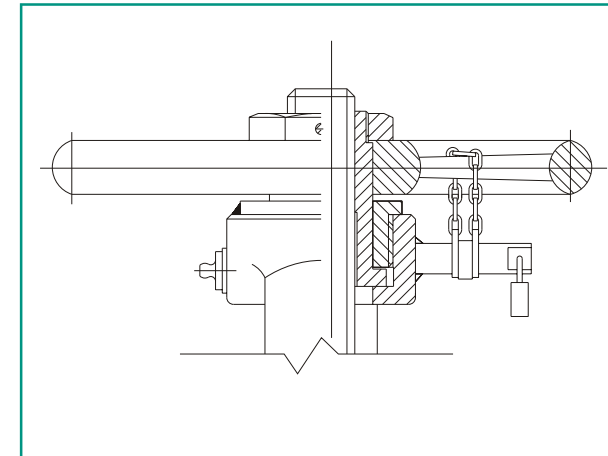

Locking device on the handwheel

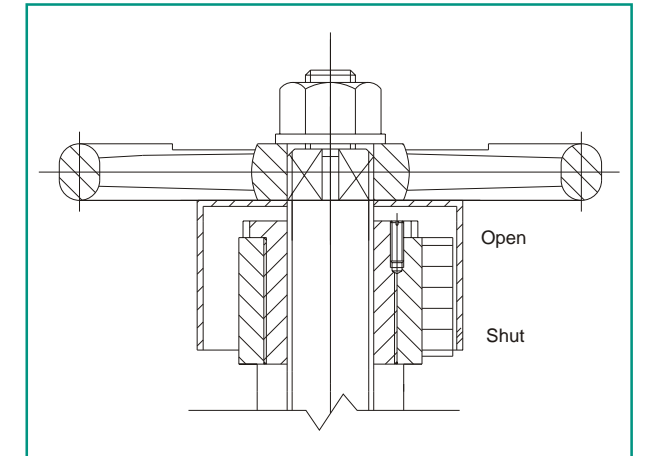

Position indicator on globe valves

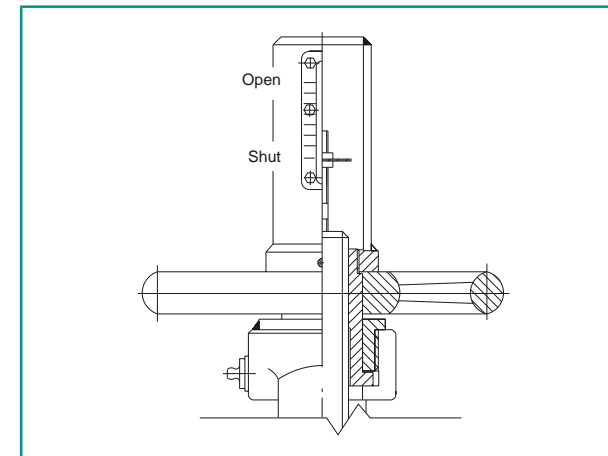

Position indicator on gate valves

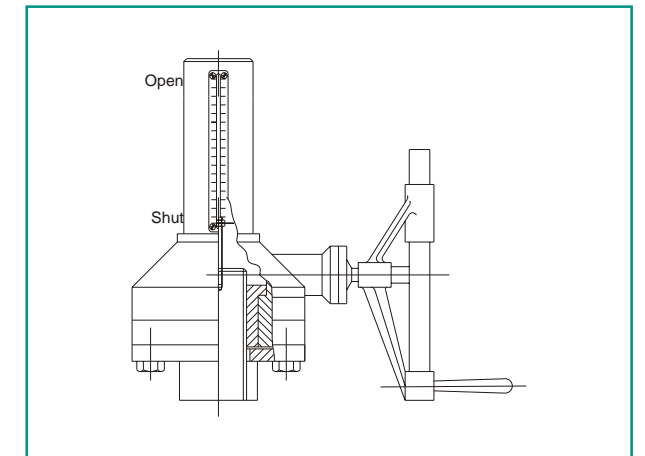

Position indicator on gear box

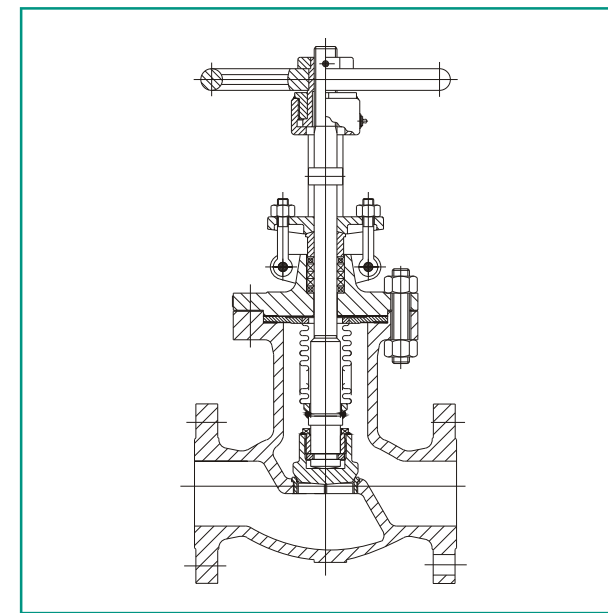

Casting steel bellow seal valves

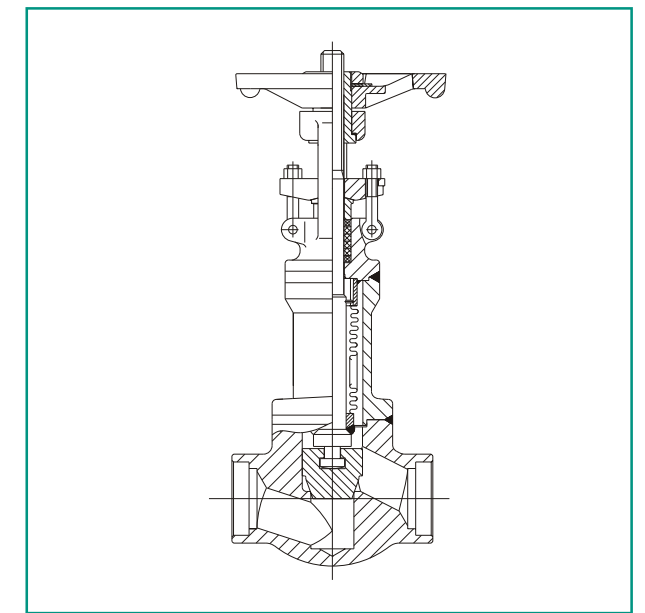

Forging steel bellow seal valves

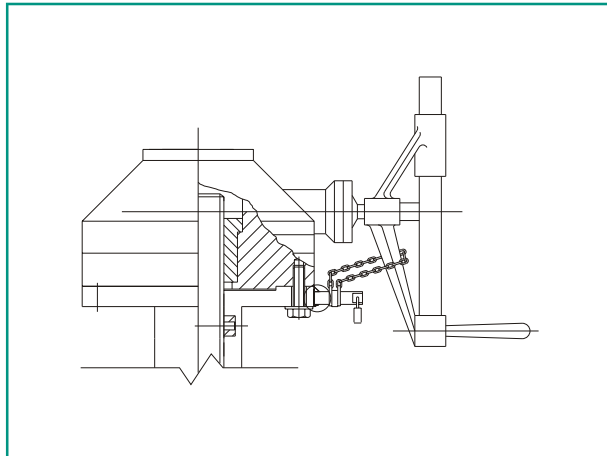

Locking device on the gear box

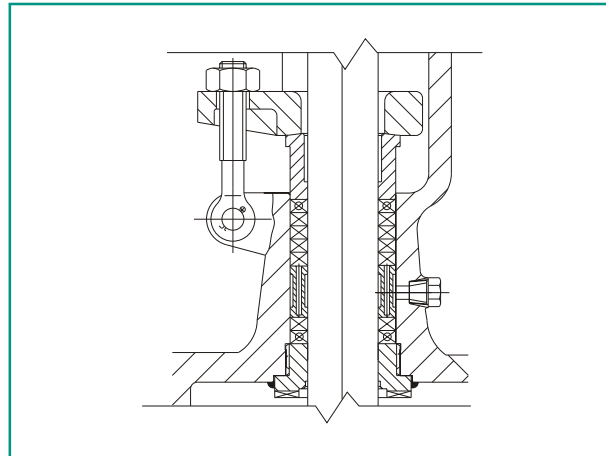

The lantern on the gate and globe valves

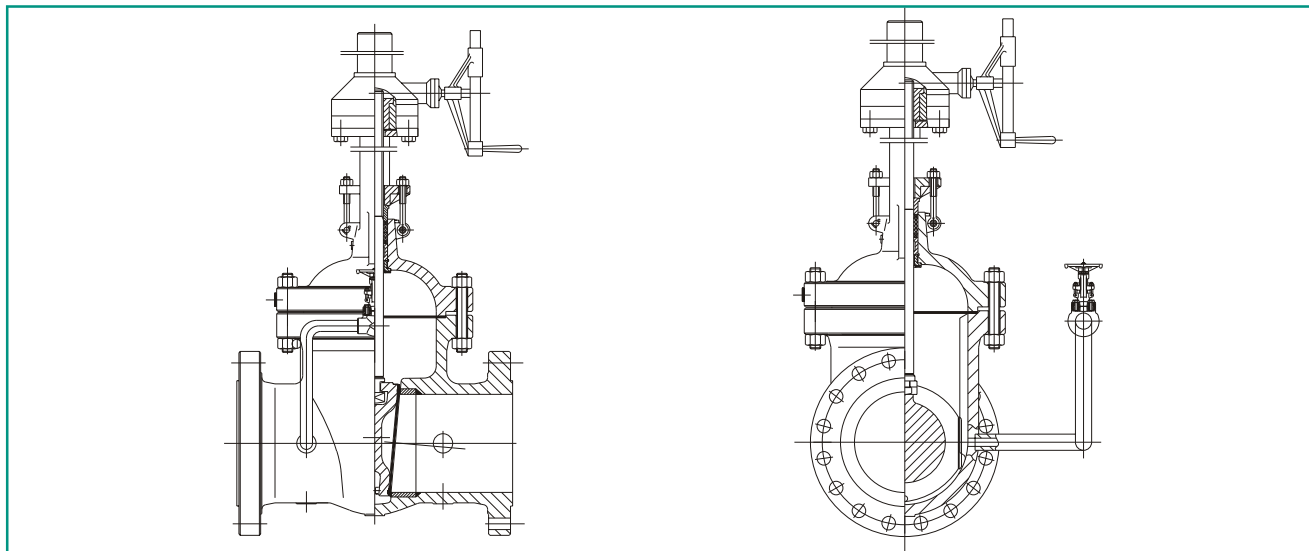

Special by-pass application

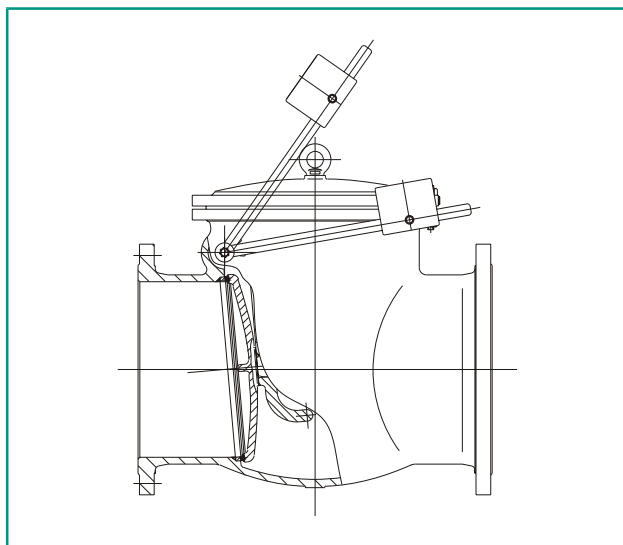

Check valves with damping box and equilibrium hammers

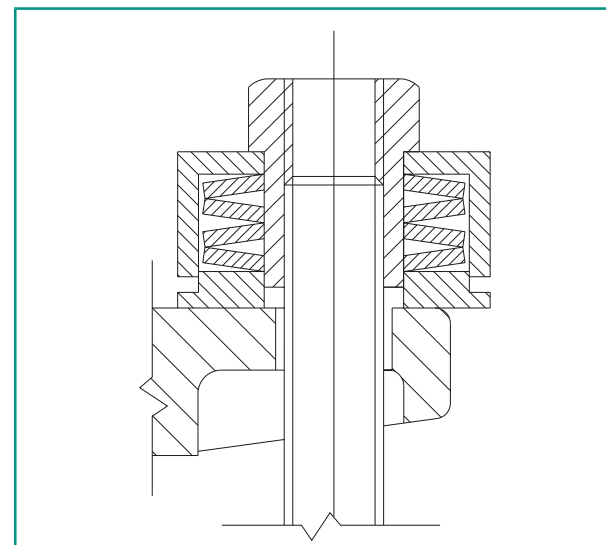

Live-loaded gland flange

Seller will replace without charge or refund the purchase price of products provided by Seller which prove to be defective in material or workmanship, provided in each case that the product is properly installed and is used in the service for which Seller recommends it and that written claim, specifying the alleged defect, is presented to the Seller within 18 months from the date of shipment or 12 months after installation, whichever occurs first. Seller shall in no event bear any labor, equipment, engineering or other costs incurred in connection with repair or replacement. The warranty stated in this paragraph is in lieu of all other warranties, either expressed or implied. With respect to warranties, this paragraph states Buyer's exclusive remedy and seller's exclusive liability.