

ALFA SERIES 5

PN 10-40/ANSI 150-600

ALFA SERIES 6

PN 10-40/ANSI 150-2500

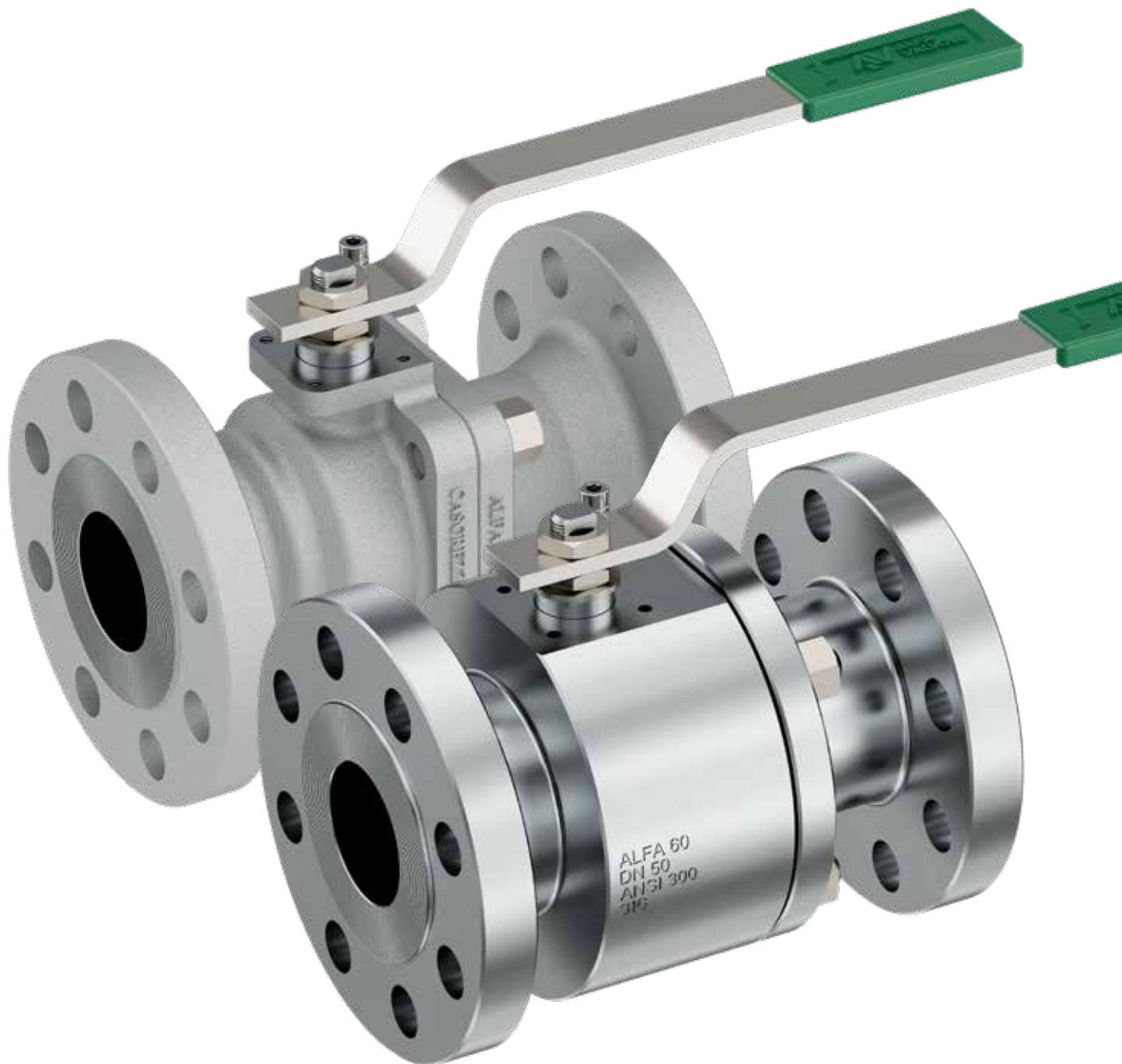



CERTIFICATIONS / CERTIFICAZIONI



UNI EN ISO 9001:2015
Cert. Nr. Nr. 50 100 6417



- TA-Luft Certificate
- Fugitive emission ISO 15848-1 & 2



FIRE SAFE API 6FA/API
607 & ISO 10497



ATEX certified by TÜV



License Nr. 6D-0195



TR-CU-10, TR-CU-12, TR-CU-32
(New GOST) certified for Russian market



CE Marking (Module H1, Category IV)
in accordance with PED 2014/68/EU
certified by TÜV



SIL (Safety integrity level)
certified by TÜV



Canadian Registration Number (CRN)
for Canadian market



ONLY ALFA 68 / SOLO ALFA 68
Cert. Nr. ADR/RID/ADN-T-AFV
002/004-17-ITA

LEGAL NOTES / NOTE LEGALI



Supplied temperature and pressure data and other performance information mentioned in this catalogue have been developed from our design calculation and internal test. The data are useful only to cover the standard application as per guidelines for Alfa Valvole products user inside this catalogue.

I dati forniti di pressione-temperatura e altri dati di prestazione pubblicati in questo catalogo sono stati sviluppati da nostri calcoli di progettazione e da test interni. Sono utili solo per coprire le applicazioni tipiche come linee guida generali per gli utenti dei prodotti Alfa Valvole introdotti in questo catalogo.

For every specific application, the users must contact Alfa Valvole for a technical assistance and/or conduct their own study and evaluation to verify the suitability of this products to defined application. Missed observance of this request should involve damages to the ownership and/or personal injury, for which the company cannot be held liable.

Even if this catalogue has been developed with the maximum attention, the company decline all responsibility for errors, impropriety or inadequacy.

Per qualsiasi applicazione specifica, gli utenti sono pregati di contattare Alfa Valvole per un consiglio tecnico e/o di condurre il proprio studio e valutazione per dimostrare l' idoneità di questi prodotti a tale applicazione. La mancata osservanza di questa richiesta potrebbe comportare danni alla proprietà e/o lesioni personali, per i quali l'azienda non potrà essere ritenuta responsabile. Sebbene questo catalogo sia stato redatto con la massima cura e attenzione, l'azienda declina ogni responsabilità per errori, improprietà o inadeguatezza.

All information mentioned in this catalogue about valves characteristics, except for that regulated from international law, may be subject to periodic change without notice.

This edition cancels and replaces all previous documents.

Please carefully read and pay attention to all guidelines for use.

For all information and/or request for further in-depth analysis please contact directly Alfa Valvole.

Private property - in observance of copyright laws in force and related rights, not authorized copying, reproduction and/or advertising, even partially, of this information to third parties without the express written and signed permission of Alfa Valvole is forbidden. All rights reserved.

Qualsiasi informazione fornita in questo catalogo relativamente alle caratteristiche delle valvole, con esclusione di quelle regolamentate da norme internazionali, può essere soggetta a modifiche periodiche senza preavviso.

Questa edizione annulla e sostituisce tutti i numeri precedenti.

Leggere attentamente e prestare attenzione alle indicazioni fornite prima dell'uso.

Per ogni informazione e/o richiesta di approfondimento ulteriori si prega di contattare direttamente Alfa Valvole.

Proprietà riservata - nel rispetto delle norme vigenti in materia di copyright e sul diritto d'autore, la copia, la riproduzione e/o la diffusione, anche parziale di informazioni e/o la comunicazione non autorizzata di dati attraverso qualsiasi mezzo a soggetti terzi, senza l'espressa autorizzazione scritta e firmata da parte di Alfa Valvole del presente documento, è proibita. Tutti i diritti riservati.

MAIN FEATURES

Caratteristiche principali

- **Split body type valve, bolted connection** / Valvola a sfera flangiata, chiusura imbullonata
- **Series 6 full bore** / Serie 6 passaggio pieno
- **Series 5 reduced bore** / Serie 5 Passaggio ridotto
- **Floating ball** / Sfera flottante
- **ONLY ALFA60/ALFA64P: light trunnion construction (pivoted ball with O-ring energized seats)** /
SOLO ALFA60P/ALFA64P: costruzione trunnion "leggera" (sfera imperniata con Seggi energizzati tramite O-Ring)
- **Wide range of application, industries and medium** / Versatilità d'uso su differenti fluidi, industrie e applicazioni
- **Available in different materials (bar stock or casting). Duplex, superduplex, nickel-based alloys, bronze-aluminium alloys and other exotic materials available on demand** / Disponibilità in diversi materiali, sia da fusione che da barra. Duplex, superduplex, Hastelloy, leghe di bronzo e altri materiali esotici disponibili su richiesta.



PRODUCT LINE



Linea prodotti

PRODUCT	CODE	TYPE						SIZE RANGES				RATING								MATERIALS						
		WAFER	3 PIECES	2 PIECES SCREWED BODY	FLANGED	3 WAY WAFER	TRUNNION	NPS 1/4 - 2 (DN 8 -50)	NPS 2 1/4 - 2 (DN 65-100)	NPS 5-8 (DN 125-200)	NPS 10-24 (DN 250-600)	PN 06	ANSI 150 (PN 10-16)	ANSI 300 (PN 25-40)	ANSI 600 (PN 63-100)	ANSI 900	ANSI 1500	ANSI 2500	800/1500 LBS	PN 63 (1000 PSI)	CARBON STEEL	STAINLESS STEEL	OTHER MATERIALS			
A10N - NF	A1N																									
A10 HP	A1H																									
A11N - NF	A1J																									
A10 CALL	A1C/D																									
A10 VAG	A1V																									
A20R / T	A2T/R																									
A22 EV	A2D																									
K20 T	K2T																									
A24K	A24																									
A60P/A64P	A6P																									
A50	A50																									
A54	A54																									
A506	A5S																									
A60	A60																									
A64	A64																									
A68	A68																									
A606	A6S																									
A609/615	A6Q																									
A625	A6V																									
A30	A30																									
A32	A32																									
M34	M34																									
A103	AC3																									
A104	AC4																									
A103/4	ACT																									
T2 FB	AT2																									
T2 RB	AT4																									
T3 FB	AT3																									
T3 RB	AT6																									

CERTIFICATIONS							
PED (DN > 25)	T PED	TA LUFT (fugitive emission)	MOCA	API 6D	FIRE TESTED	SIL	ATEX

INDUSTRY											CODE	PRODUCT
POWER	OIL AND GAS UPSTREAM	REFINING AND PETROCHEMICAL	CHEMICAL	LNG AND CRYOGENIC	MARINE AND NAVY	HVAC	WATER AND WASTEWATER	PHARMACEUTICAL	RAIL AND ROAD TRANSPORTATION	FOOD INDUSTRY		
											A1N	A10N - NF
											A1H	A10 HP
											A1J	A11N - NF
											A1C/D	A10 CALL
											A1V	A10 VAG
											A2T/R	A20R / T
											A2D	A22 EV
											K2T	K20 T
											A24	A24K
											A6P	A60P/A64P
											A50	A50
											A54	A54
											A5S	A506
											A60	A60
											A64	A64
											A68	A68
											A6S	A606
											A6Q	A609/615
											A6V	A625
											A30	A30
											A32	A32
											M34	M34
											AC3	A103
											AC4	A104
											ACT	A103/4
											AT2	T2 FB
											AT4	T2 RB
											AT3	T3 FB
											AT6	T3 RB

STANDARD FEATURES

Caratteristiche standard

- **Size range / Range dimensioni:** $\frac{1}{2}'' \leq DN \leq 10''$ / $15 \leq DN \leq 250$
- **Pressure range / Range di pressioni:** ANSI 150-2500 / PN 10-100
- **Standard temperature range * / Range temperatura standard *:** $-40^{\circ}\text{C} \leq T \leq +200^{\circ}\text{C}$
- **Flange facing RF according to / Finitura flange secondo:** ASME B16.5 (ANSI) / EN 1092-1 (PN)
- **Flange drilling, smooth holes according / Foratura flange secondo:** ASME B16.5 (ANSI) / EN 1092-1 (PN)
- **Face to face / Scartamento:** ASME B16.10 (ANSI) / EN 558-1 F4 (A68) / EN 558-1 F5 (A68 DN80/100 PN 25-40 and all rating for $DN \geq 125$)
- **Designed according to / Progettazione secondo:** ASME B16.34 / EN 12516-1 / EN 17292 / API6D (ANSI) / PED 2014/68/UE
- **Tightness class / Classe di tenuta:** grade A (Zero Leakage) acc. EN 12266-1

* For detailed values about pressure/temperature limits, please refer to diagrams from page 27 to page 31 / Per i dettagli sui limiti di pressione/temperatura relativi a ciascuna valvola consultare i diagrammi di riferimento da pag. 27 a pag. 31

PRODUCT VARIANTS

Varianti di prodotto

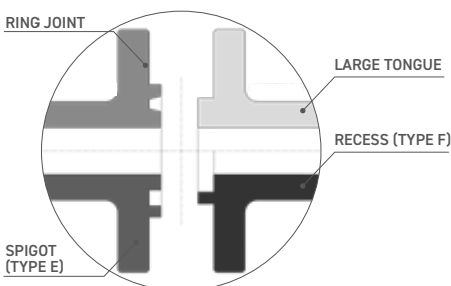

FLANGE FACING / FINITURA FLANGE

Available all flange facings, according ASME/EN standards.

TYPE C/D/E/F on EN flanges (A68) on casting and bar executions

TYPE RJ/LF/LG/SF/SG on ANSI flanges only on bar executions, due to the different face to face

BW ASME B16.25

SW ASME B16.11

Disponibili tutte le finiture flange secondo ASME/EN standard.

TIPO C/D/E/F su flange EN (A68) sia da barra che da fusione

TIPO RJ/LF/LG/SF/SG su flange ANSI solo da barra, dovuto al diverso scartamento

BW ASME B16.25

SW ASME B16.11

DOUBLE BLOCK & BLEED VALVES *

Double ball + threaded/flanged drain valve that allow to drain the medium inside the body valve in closure (only on bar stock valves, special execution, customized face to face) / Doppia sfera + valvola filettata/flangiata di scarico per drenare tutto il fluido presente nel corpo valvola in fase di chiusura (solo su valvole da barra, esecuzione speciale, scartamento su commessa)

* Refer to page 37-38 / Vedi pag. 37-38

F1 FtF / SCARTAMENTO F1 *

Valve family ALFA 68 is available with special Face to Face according to standard DIN 3202-1 F1 (equivalent to EN558-1 Serie 1), specifically designed for chemical applications.

Valve available both by forged bar and casting.

La famiglia di valvole ALFA 68 è disponibile anche con scartamento speciale in accordo alle norme DIN 3202-1 F1 (equivalente a EN558-1 serie 1), specificamente studiata per l'industria chimica.

Valvola disponibile sia da barra che da fusione.

* Refer to page 11-12 / Vedi pag. 11-12

STANDARD EXECUTIONS

Esecuzioni standard



ISO 5211 TOP MOUNTING

Valve top flange is machined for actuator assembly according to ISO 5211 / Foratura premistoppa per montaggio comando secondo normativa ISO 5211

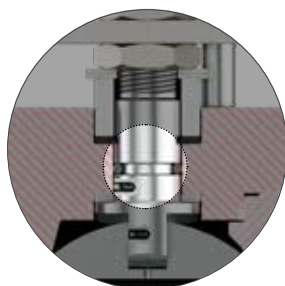

STEM O'RING / O'RING STELO

Maximum tightness from stem packing minimizing Fugitive Emissions (valve certified TA-LUFT e Fugitive Emissions EN 15848-1/-2) / Garantisce la tenuta ottimale dallo stelo minimizzando le emissioni in atmosfera, rendendo le valvole certificate TA-LUFT e Fugitive Emissions EN 15848-1/-2

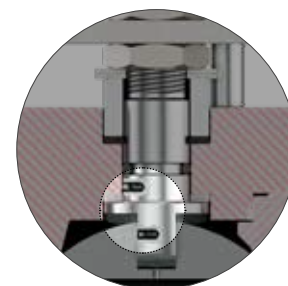

ANTISTATIC DEVICE ACCORDING /
DISPOSITIVO ANTISTATICO IN ACCORDO
A: API6D - ATEX 2014/34/UE

2 spring loaded balls guarantees electrical continuity between all metallic components of the valve / Garantisce continuità elettrica tra i componenti metallici della valvola grazie a due sfere posizionate sullo stelo

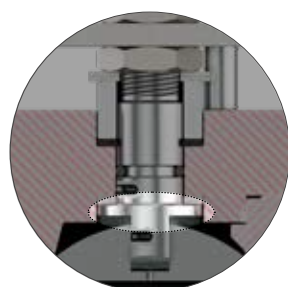

ANTI BLOW-OUT STEM DESIGN / STELO
ANTIESPULSIONE

In case of overpressure inside the valve it avoid the stem expulsion and the breakage of the operating element / Evita l'espulsione dello stelo in caso di sovrappressione all'interno della valvola e la rottura dell'elemento di manovra

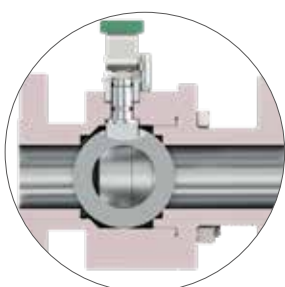

FIRE SAFE GASKET CONFIGURATION /
CONFIGURAZIONE FIRE SAFE

Materials, gaskets and sealing tested and certified according to EN10497, API6FA, API607 standards / Materiali, guarnizioni e tenute testate e certificate secondo norme EN ISO 10497, API 6FA, API 607

**ALFA 64
ANSI 150**
Split body ball valve - Full bore

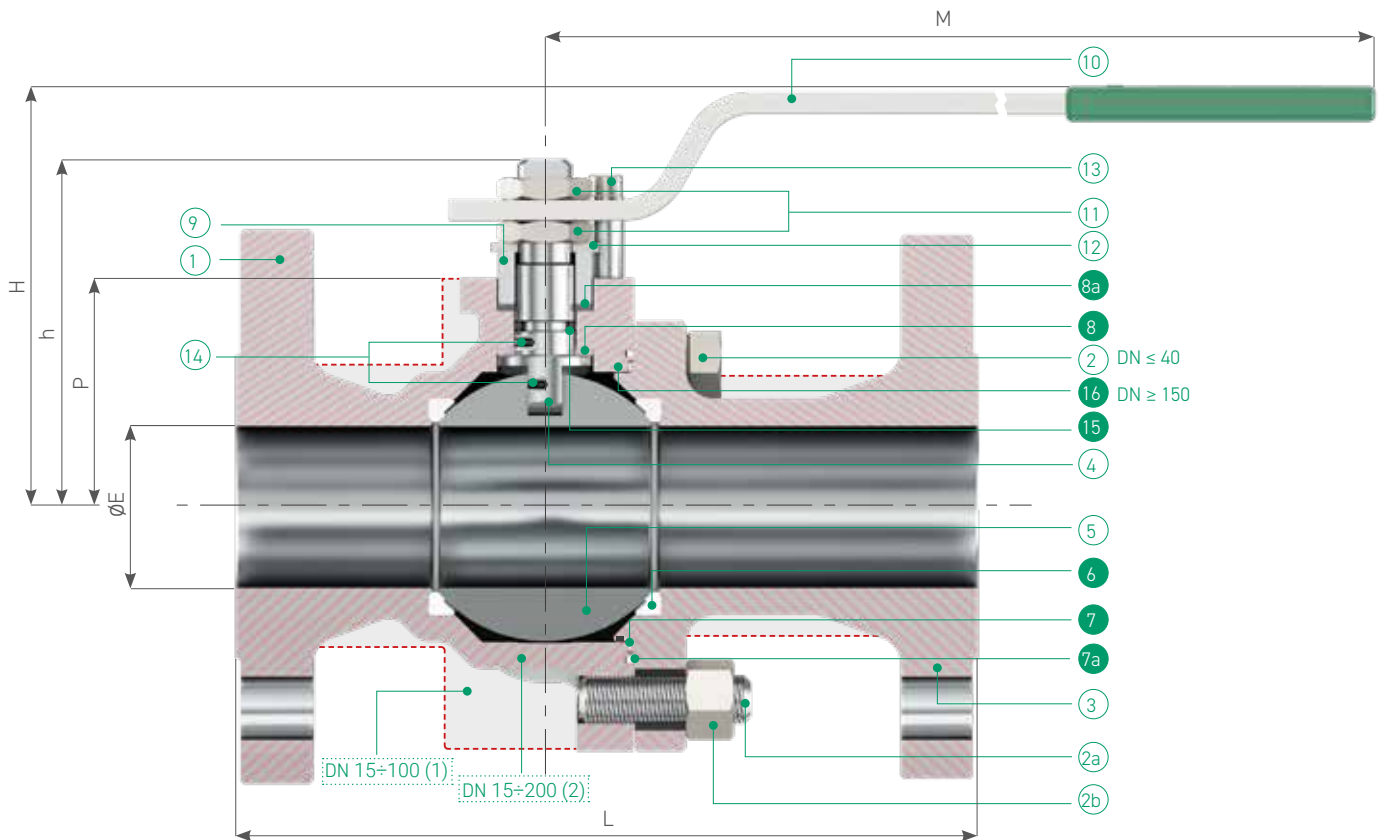

Handwheel gearbox / Riduttore con volantino
Standard DN 200

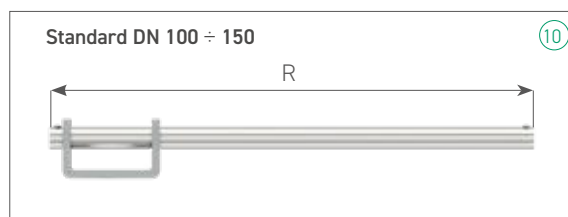

Actuator - valve coupling /
Accoppiamento valvola - attuatore
ISO 5211

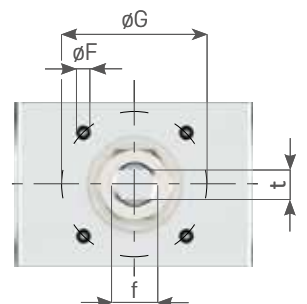

Standard valve materials / Materiali costruzione valvola standard

PART NAME PARTICOLARE		Q.TY Q.TA'	MATERIALS MATERIALI			
		CARBON STEEL			STAINLESS STEEL	
		BAR STOCK BODY CORPO DA BARRA	INVESTMENT CASTING BODY CORPO DA FUSIONE	BAR STOCK BODY CORPO DA BARRA	INVESTMENT CASTING BODY CORPO DA FUSIONE	
1	body corpo	1	ASTM A105N/LF2	ASTM A216 WCB	ASTM A479 316/316L	ASTM A351 CF8M
2	screw vite	4	ASTM A193 B7 (DN ≤ 40)		ASTM A193 B8M (DN ≤ 40)	
2a	stud tirante	4/8	ASTM A193 B7		ASTM A193 B8M	
2b	nut dado	4/8	ASTM A194 2H		ASTM A194 B8	
3	closure chiusura	1	ASTM A105N/LF2	ASTM A216 WCB	ASTM A479 316/316L	ASTM A351 CF8M
4	stem stelo	1	ASTM A479 F6a (AISI 410)		ASTM A182 316/316L	
5	ball sfera	1	ASTM A351 CF8		ASTM A351 CF8M	
6	seats sedi	2	TFM	TFM (PTFE + A.M. : DN = 200)	TFM	TFM (PTFE + A.M. : DN = 200)
7	1 st body gasket guarnizione corpo int.	1	P.T.F.E.	P.T.F.E. (DN ≤ 80)	P.T.F.E.	P.T.F.E. (DN ≤ 80)
7a	2 nd body gasket guarnizione corpo est.	1	GRAPHOIL			
8	washer bussola	1	P.T.F.E.			
8a	stem gasket guarnizione stelo	2	GRAPHOIL			
9	gland premi-guarnizione	1	Carbon Steel Zinc Coated		Stainless steel 316	
10	lever leva	1	Carbon Steel Zinc Coated			
11	stem nut dado stelo	2	Cl. 8		A4-40 (AISI 316)	
12	spring washer molla a tazza	2	51CrV4 Zinc Coated		AISI 316	
13	stop device dispositivo di arresto	1	Cl.8.8 Zinc Coated		AISI 316	
14	antistatic device dispositivo antistatico	2	AISI 316			
15	stem O-ring O-ring stelo	1	VITON 75 Sh. A			
16	body O-ring O-ring corpo	1	N.A.	P.T.F.E. (DN ≥ 100)	N.A.	P.T.F.E. (DN ≥ 100)

 Spares parts / Parti di ricambio

DIMENSIONS / DIMENSIONI

DN	15	20	25	32	40	50	65	80	100	125	150	200
ø"	½"	¾"	1"	1¼"	1½"	2"	2½"	3"	4"	5"	6"	8"
ø E	14	19	24	29	38	51	64	76	102	118	152	203
L	108	117	127	140	165	178	190	203	229	254	394	457
M/R	150/-	150/-	185/-	185/-	275/-	275/-	380/-	380/-	440/500	440/500	-/800	*
H	84	87	95	99	118	126	143	149	191	200	273	322
h	52	54	69	72	95	103	122	127	157	166	218	270
P	33	36	43	48	63	68,5	82	88,5	111	120	153	200
f/t	10/6	10/6	12/8	12/8	16/10	16/10	22/14	22/14	30/18	30/18	45/30	52/30
Kg. (1)/(2)	2,5/1,8	3/2,6	5,5/3,3	7/4,4	11/6,9	16/10	22/17	26/20,5	42/35	-/43	-/71	-/110
ISO 5211	F03	F03	F03	F03	F05	F05	F07	F07	F10	F10	F14	F14
ø F	M5	M5	M5	M5	M6	M6	M8	M8	M10	M10	M16	M16
ø G	36	36	36	36	50	50	70	70	102	102	140	140

* Available with handwheel gearbox only / Disponibile solo con riduttore manuale

For DN > 200 refer to ALFA 64P / Per DN > 200 vedi ALFA 64P

(1) = Bar stock body / Corpo da barra

(2) = Investment casting body / Corpo da fusione



**ALFA 60
ANSI 300**
Split body ball valve - Full bore

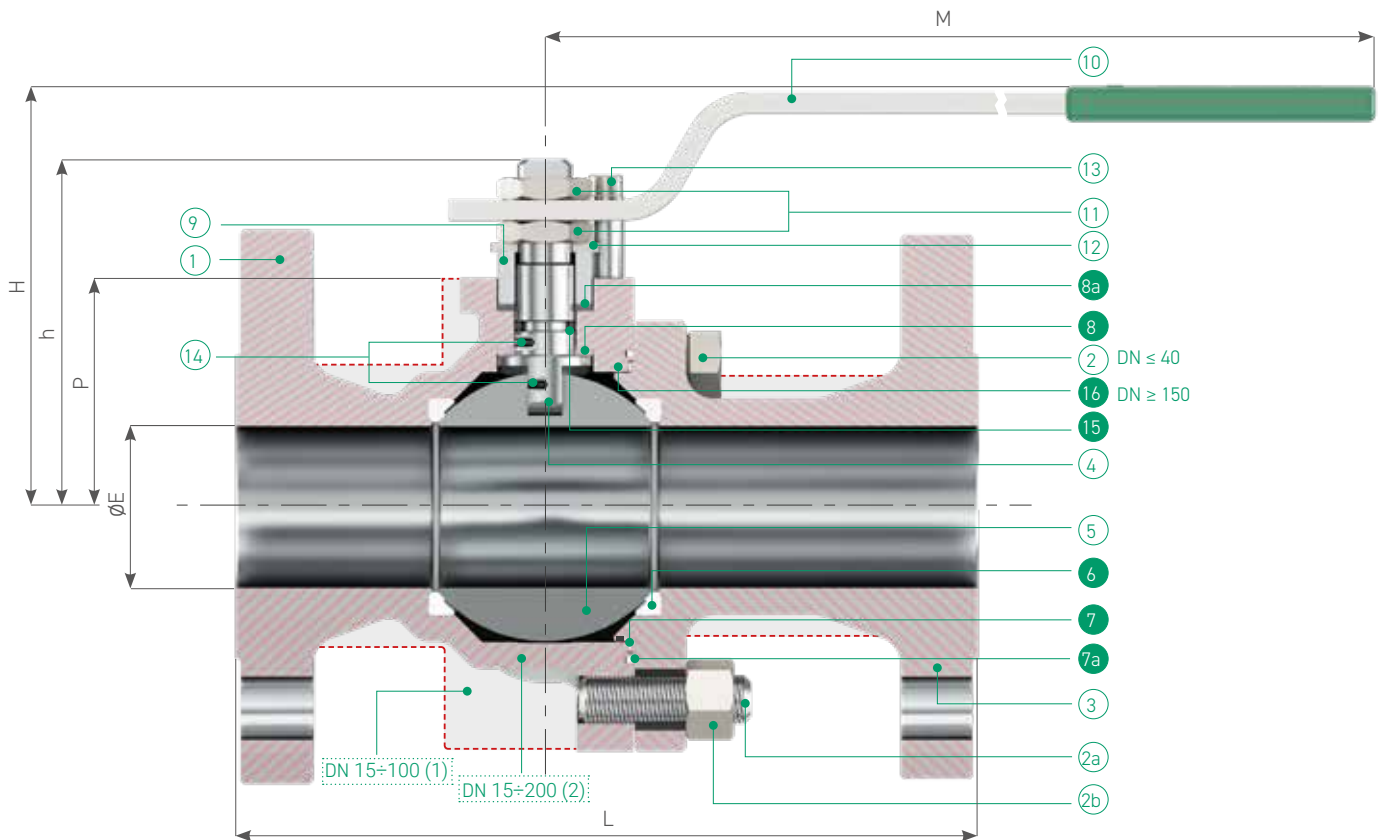

Handwheel gearbox / Riduttore con volantino
Standard DN 150

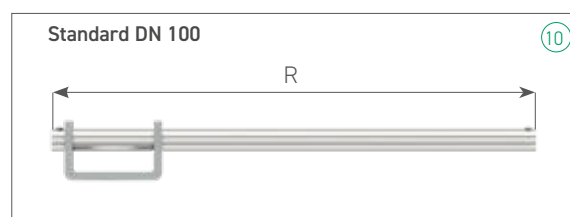

Actuator - valve coupling /
Accoppiamento valvola - attuatore
ISO 5211

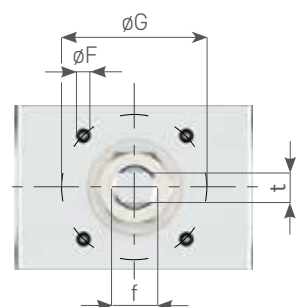

ALFA 60 ANSI 300

Standard valve materials / Materiali costruzione valvola standard

PART NAME PARTICOLARE		Q.TY Q.TA'	MATERIALS MATERIALI			
		CARBON STEEL		STAINLESS STEEL		
		BAR STOCK BODY CORPO DA BARRA	INVESTMENT CASTING BODY CORPO DA FUSIONE	BAR STOCK BODY CORPO DA BARRA	INVESTMENT CASTING BODY CORPO DA FUSIONE	
1	body corpo	1	ASTM A105N/LF2	ASTM A216 WCB	ASTM A479 316/316L ASTM A351 CF8M	
2	screw vite	4	ASTM A193 B7 (DN ≤ 40)		ASTM A193 B8M (DN ≤ 40)	
2a	stud tirante	4/8	ASTM A193 B7		ASTM A193 B8M	
2b	nut dado	4/8	ASTM A194 2H		ASTM A194 B8	
3	closure chiusura	1	ASTM A105N/LF2	ASTM A216 WCB	ASTM A479 316/316L ASTM A351 CF8M	
4	stem stelo	1	ASTM A479 F6a (AISI 410)		ASTM A182 316/316L	
5	ball sfera	1	ASTM A351 CF8		ASTM A351 CF8M	
6	seats sedi	2	TFM	TFM/PTFE +AM (DN = 150)	TFM TFM/PTFE +AM (DN = 150)	
7	1 st body gasket guarnizione corpo int.	1	P.T.F.E.	P.T.F.E. (DN ≤ 80)	P.T.F.E. (DN ≤ 80)	
7a	2 nd body gasket guarnizione corpo est.	1	GRAPHOIL			
8	washer bussola	1	P.T.F.E.			
8a	stem gasket guarnizione stelo	2	GRAPHOIL			
9	gland premi-guarnizione	1	Carbon Steel Zinc Coated		Stainless steel 316	
10	lever leva	1	Carbon Steel Zinc Coated			
11	stem nut dado stelo	2	Cl. 8		A4-40 (AISI 316)	
12	spring washer molla a tazza	2	51CrV4 Zinc Coated		AISI 316	
13	stop device dispositivo di arresto	1	Cl.8.8 Zinc Coated		AISI 316	
14	antistatic device dispositivo antistatico	2	AISI 316			
15	stem O-ring O-ring stelo	1	VITON 75 Sh. A			
16	body O-ring O-ring corpo	1	N.A.	P.T.F.E. (DN ≥ 100)	N.A. P.T.F.E. (DN ≥ 100)	

 Spares parts / Parti di ricambio

DIMENSIONS / DIMENSIONI

DN	15	20	25	32	40	50	65	80	100	150
ø"	½"	¾"	1"	1¼"	1½"	2"	2½"	3"	4"	6"
ø E	14	19	24	29	38	51	64	76	102	152
L	140	152	165	178	191	216	241	283	305	403
M/R	150/-	150/-	185/-	185/-	275/-	275/-	380/-	380/-	440/500	*
H	84	87	95	99	118	126	143	149	191	273
h	52	54	69	72	103	103	122	127	157	218
P	33	36	43	48	63	68.5	82	88.5	111	153
f/t	10/6	10/6	12/8	12/8	16/10	16/10	22/14	22/14	30/18	45/30
Kg. (1)/(2)	3/2,3	4/3,8	6/4,6	8/6,2	13,5/9,8	19/12,4	25/20	37/31	63/45	-/105
ISO 5211	F03	F03	F03	F03	F05	F05	F07	F07	F10	F14
ø F	M5	M5	M5	M5	M6	M6	M8	M8	M10	M16
ø G	36	36	36	36	50	50	70	70	102	140

* Available with handwheel gearbox only / Disponibile solo con riduttore manuale

For DN ≥ 200 refer to ALFA 60P / Per DN ≥ 200 vedi ALFA 60P

(1) = Bar stock body / Corpo da barra

(2) = Investment casting body / Corpo da fusione



ALFA 68
PN 10-40
 Split body ball valve - Full bore

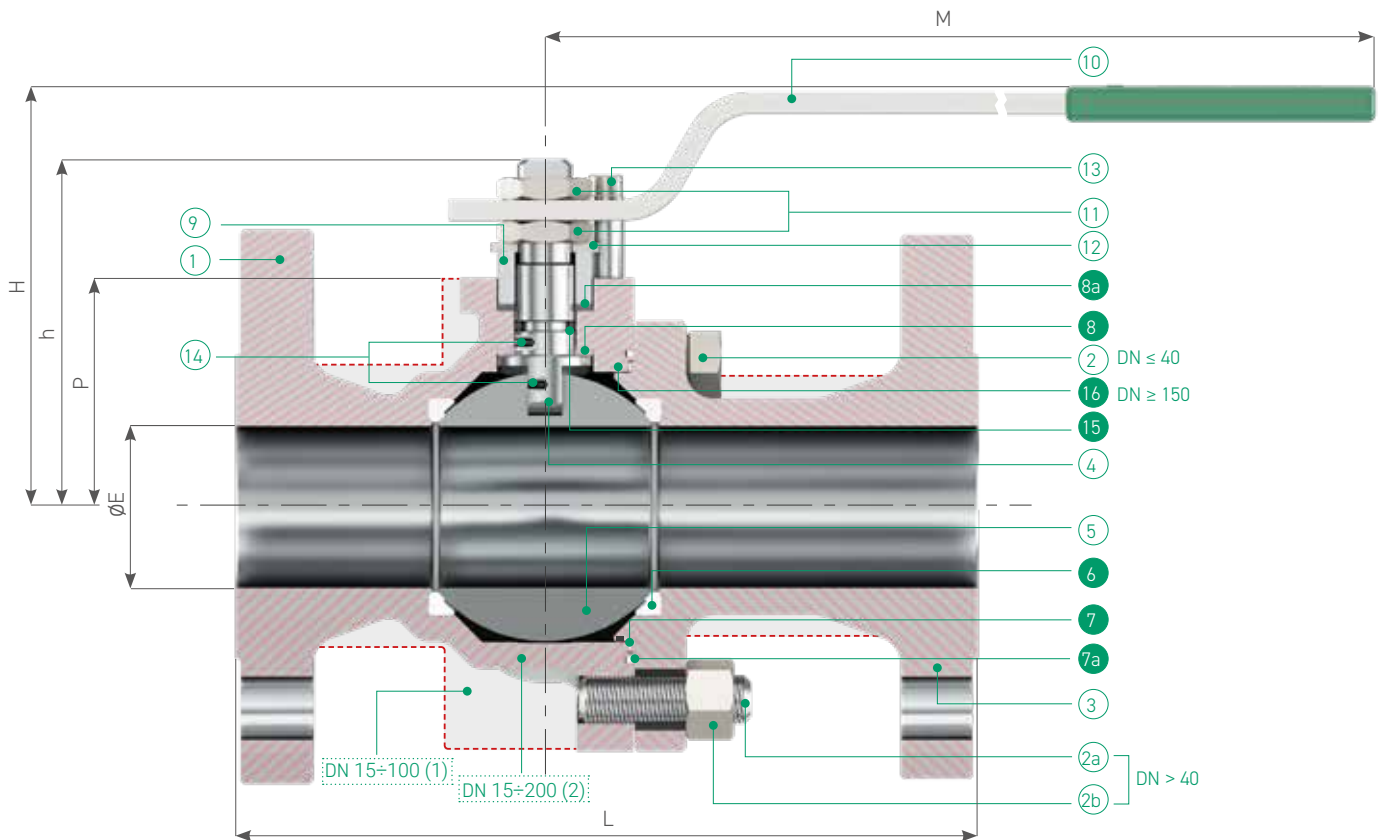

Handwheel gearbox / Riduttore con volante
 Only on request / Solo su richiesta

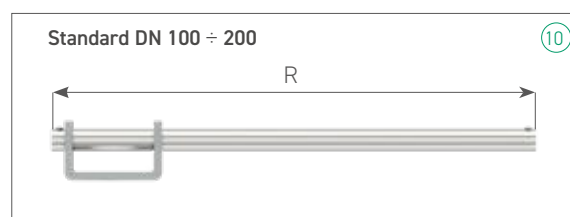

Actuator - valve coupling /
 Accoppiamento valvola - attuatore
 ISO 5211

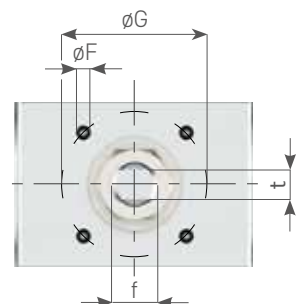

Standard valve materials / Materiali costruzione valvola standard

PART NAME PARTICOLARE		Q.TY Q.TA'	MATERIALS MATERIALI			
			CARBON STEEL		STAINLESS STEEL	
			BAR STOCK BODY CORPO DA BARRA	INVESTMENT CASTING BODY CORPO DA FUSIONE	BAR STOCK BODY CORPO DA BARRA	INVESTMENT CASTING BODY CORPO DA FUSIONE
1	body corpo	1	ASTM A105N/LF2	ASTM A216 WCB	ASTM A479 316/316L	ASTM A351 CF8M
2	screw vite	4	ASTM A193 B7 (DN ≤ 40)	ASTM A193 B7 (DN ≤ 65)	ASTM A193 B8M (DN ≤ 40)	ASTM A193 B8M (DN ≤ 65)
2a	stud tirante	4/8	ASTM A193 B7		ASTM A193 B8M	
2b	nut dado	4/8	ASTM A194 2H		ASTM A194 B8	
3	closure chiusura	1	ASTM A105N/LF2	ASTM A216 WCB	ASTM A479 316/316L	ASTM A351 CF8M
4	stem stelo	1	ASTM A479 F6a (AISI 410)	ASTM A182 316/316L	ASTM A182 316/316L	
5	ball sfera	1	ASTM A351 CF8	ASTM A351 CF8M	ASTM A351 CF8M	
6	seats sedi	2	TFM			
7	1 st body gasket guarnizione corpo int.	1	P.T.F.E.	P.T.F.E. (DN ≤ 80)	P.T.F.E.	P.T.F.E. (DN ≤ 80)
7a	2 nd body gasket guarnizione corpo est.	1	GRAPHOIL			
8	washer bussola	1	P.T.F.E.			
8a	stem gasket guarnizione stelo	2	GRAPHOIL			
9	gland premi-guarnizione	1	Carbon Steel Zinc Coated		Stainless Steel 316	
10	lever leva	1	Carbon Steel Zinc Coated			
11	stem nut dado stelo	2	Cl. 8		A4-40 (AISI 316)	
12	spring washer molla a tazza	2	51CrV4 Zinc Coated		AISI 316	
13	stop device dispositivo di arresto	1	Cl. 8.8 Zinc Coated		AISI 316	
14	antistatic device dispositivo antistatico	2	AISI 316			
15	stem O-ring O-ring stelo	1	VITON 75 Sh. A			
16	body O-ring O-ring corpo	1	N.A.	P.T.F.E. (DN ≥ 100)	N.A.	P.T.F.E. (DN ≥ 100)

Spares parts / Parti di ricambio

DIMENSIONS / DIMENSIONI

															ONLY PN 10/16
	PN 10/16		PN 25/40		PN 10/16		PN 25/40								
DN	15	20	25	32	40	50	65	80	80	100	100	125	150	200	
ø"	½"	¾"	1"	1¼"	1½"	2"	2½"	3"	3"	4"	4"	5"	6"	8"	
ø E	14	19	24	29	38	51	64	76	76	102	102	118	152	203	
L	115	120	125	130	140	150	170	180	280	190	300	325	350	400	
DIN 3202	F4	F4	F4	F4	F4	F4	F4	F4	F5	F4	F5	F5	F5	F5	
M/R	150/-	150/-	185/-	185/-	275/-	275/-	380/-	380/-	380/-	440/500	440/500	440/500	-/800	-/800	
H	84	87	95	99	116	124	143	149	149	202,5	202,5	200	273	322	
h	52	54	69	72	95	103	122	127	127	157	157	166	218	270	
P	33	36	43	48	63	68,5	82	88,5	88,5	111	111	120	153	200	
f/t	10/6	10/6	12/8	12/8	16/10	16/10	22/14	22/14	22/14	30/18	30/18	30/18	45/30	52/30	
Kg. (1)/(2)	2,7/2,4	3/2,8	5,5/4,0	6,8/5,7	12,1/7,6	15,5/10,4	21/14,5	25,9/19	33/23,5	39,4/28,5	55/35	-/48	-/70	-/105	
ISO 5211	F03	F03	F03	F03	F05	F05	F07	F07	F07	F10	F10	F10	F14	F14	
ø F	M5	M5	M5	M5	M6	M6	M8	M8	M8	M10	M10	M10	M16	M16	
ø G	36	36	36	36	50	50	70	70	70	102	102	102	140	140	
PN	40	40	40	40	40	40	40	40	40	16	16	16	16	16	

Valve available with Face to Face DIN 3202-1 F1 / Valvola disponibile con scartamento DIN 3202-1 F1

(1) = Bar stock body / Corpo da barra

(2) = Investment casting body / Corpo da fusione



ALFA 606

ANSI 600

Split body ball valve - Full bore

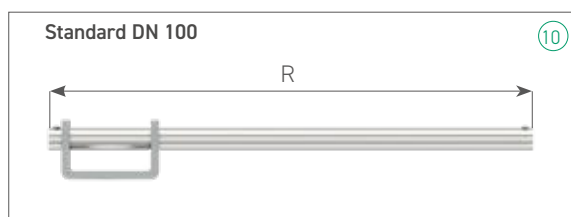
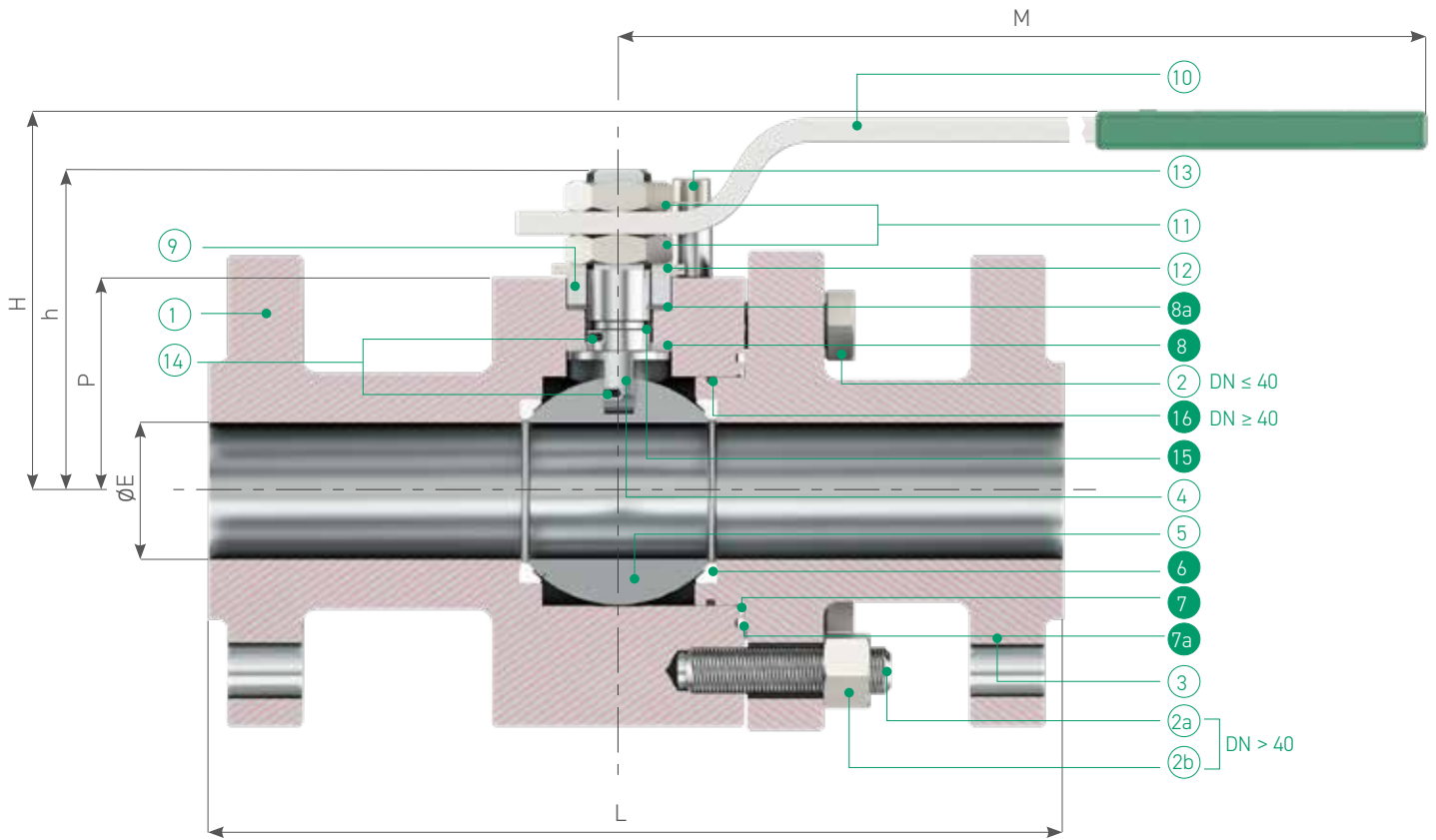

Actuator - valve coupling /
Accoppiamento valvola - attuatore
ISO 5211

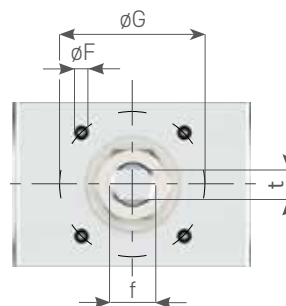

ALFA 606 ANSI 600

Standard valve materials / Materiali costruzione valvola standard

PART NAME PARTICOLARE		Q.TY Q.TA	CARBON STEEL	STAINLESS STEEL
BAR STOCK BODY CORPO DA BARRA				
1	body corpo	1	ASTM A105N/LF2	ASTM A479 316/316L
2	screw vite	4	ASTM A193 B7 (DN ≤ 40)	ASTM A193 B8M (DN ≤ 40)
2a	stud tirante	4/8	ASTM A193 B7	ASTM A193 B8M
2b	nut dado	4/8	ASTM A194 2H	ASTM A194 B8
3	closure chiusura	1	ASTM A105N/LF2	ASTM A479 316/316L
4	stem stelo	1	ASTM A182 F51	
5	ball sfera	1	ASTM A351 CF8	ASTM A351 CF8M
6	seats sedi	2	TFM / PTFE + AM (DN ≥ 40)	
7	1 st body gasket guarnizione corpo int.	1	P.T.F.E. (DN ≤ 80)	
7a	2 nd body gasket guarnizione corpo est.	1	GRAPHOIL	
8	washer bussola	1	P.T.F.E.	
8a	stem gasket guarnizione stelo	2	GRAPHOIL	
9	gland premi-guarnizione	1	Carbon Steel Zinc Coated	Stainless Steel 316
10	lever leva	1	Carbon Steel Zinc Coated	
11	stem nut dado stelo	2	Cl. 8	A4-40 (AISI 316)
12	spring washer molla a tazza	2	51CrV4 Zinc Coated	AISI 316
13	stop device dispositivo di arresto	1	Cl. 8.8 Zinc Coated	AISI 316
14	antistatic device dispositivo antistatico	2	AISI 316	
15	stem O-ring O-ring stelo	1	VITON 90 sh. A AED	
16	body O-ring O-ring corpo	1	P.T.F.E. (DN ≥ 40)	

 Spares parts / Parti di ricambio

DIMENSIONS / DIMENSIONI

DN	15	20	25	40	50	80	100
ø"	½"	¾"	1"	1½"	2"	3"	4"
ø E	14	19	24	38	51	76	102
L	165	191	216	241	292	356	432
M/R	150/-	150/-	275/-	380/-	380/-	440/500	-/800
H	84	87	101	125	134	174	236
h	51	54	76	104	113	141	181
P	33	36	51	65	75	95	124
f/t	10/6	10/6	16/10	22/14	22/14	30/18	45/30
Kg.	7	8,5	10	18,5	25	50	125
ISO 5211	F03	F03	F05	F07	F07	F10	F14
ø F	M5	M5	M6	M8	M8	M10	M16
ø G	36	36	50	70	70	102	140

Available flanged PN 63/100 on request / Disponibile flangiata PN 63/100 su richiesta

(P,T) DIAGRAMS / DIAGRAMMI (P,T)

TFM/PTFE + METAL CORE SEATS / SEDI IN TFM/PTFE + AM

½" ≤ DN ≤ 4"

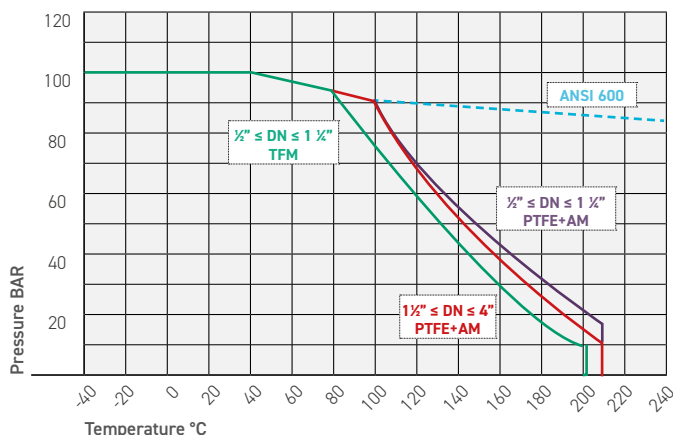

Select 1 size lower (es. for DN 50 select DN 40) / Selezionare una taglia inferiore a quella desiderata (ad esempio: per DN 50 analizzare dati DN 40)

DN	½" ≤ DN ≤ 1 ½" (15 ≤ DN ≤ 50)
P max @ Tmax	6,5 bar @ 200°C (TFM SEATS) 10 bar @ 210°C (PTFE + AM SEATS)

DN	1 ½" ≤ DN ≤ 4" (65 ≤ DN ≤ 100)
P max @ Tmax	9 bar @ 210°C (PTFE + AM SEATS)



ALFA 609/615
ANSI 900-1500
 Split body ball valve - Full bore

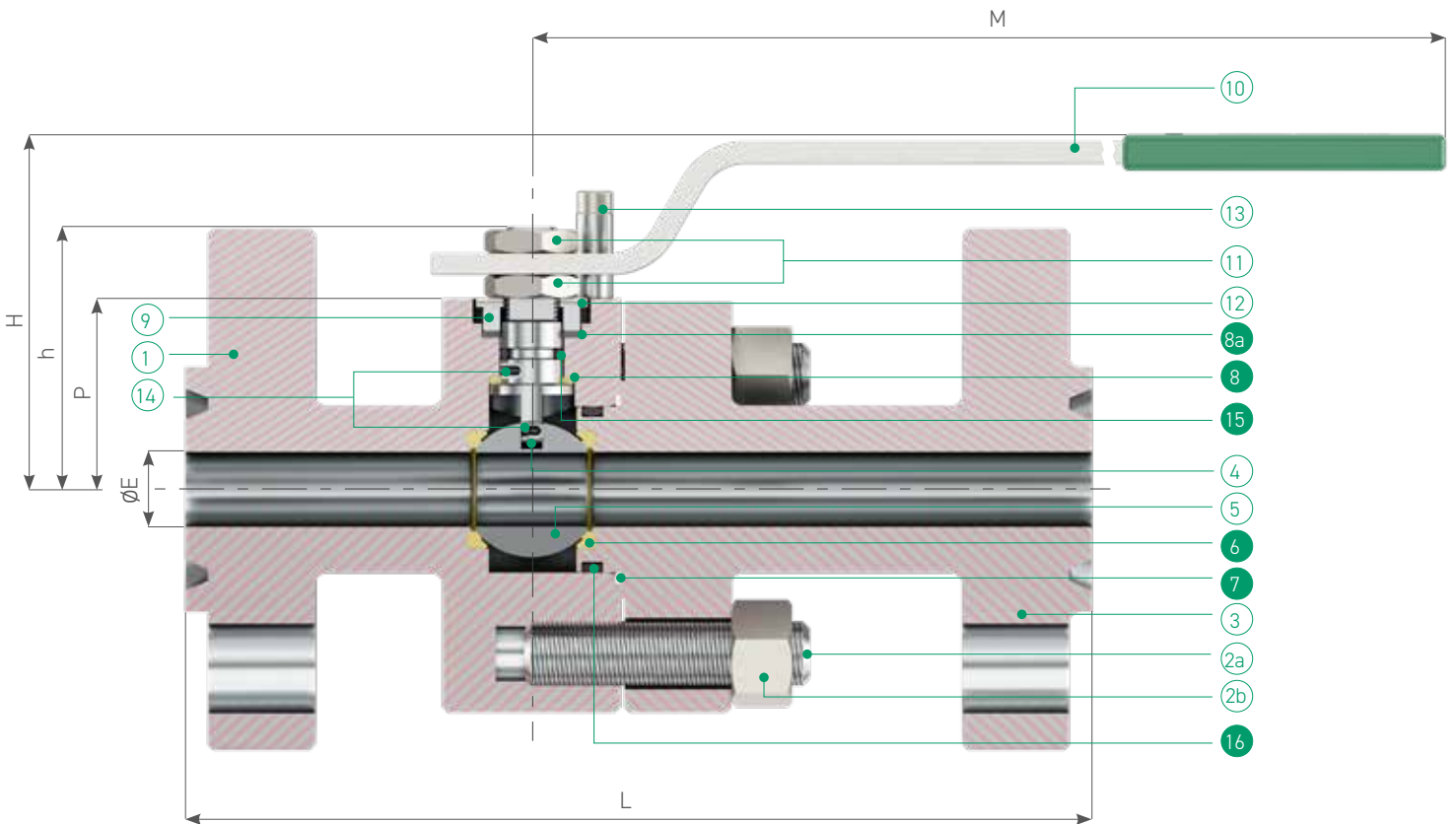

Actuator - valve coupling /
 Accoppiamento valvola - attuatore
 ISO 5211

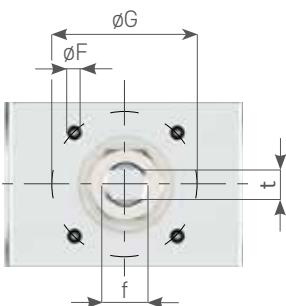

ALFA 609/615 ANSI 900-1500

Standard valve materials / Materiali costruzione valvola standard

PART NAME PARTICOLARE		Q.TY Q.TA	CARBON STEEL	STAINLESS STEEL
BAR STOCK BODY CORPO DA BARRA				
1	body corpo	1	ASTM A105N/LF2	ASTM A479 316/316L
2a	stud tirante	4/8	ASTM A193 B7	ASTM A193 B8M
2b	nut dado	4/8	ASTM A194 2H	ASTM A194 B8
3	closure chiusura	1	ASTM A105N/LF2	ASTM A479 316/316L
4	stem stelo	1	ASTM A182 F51	
5	ball sfera	1	ASTM A182 F51	
6	seats sedi	2	DEVLON	
7	1 st body gasket guarnizione corpo int.	1	P.T.F.E.	
8	washer bussola	1	DEVLON	
8a	stem gasket guarnizione stelo	2	GRAPHOIL	
9	gland preguarnizione	1	Carbon Steel Zinc Coated	Stainless Steel 316
10	lever leva	1	Carbon Steel Zinc Coated	
11	stem nut dado stelo	2	Cl. 8	A4-40 (AISI 316)
12	spring washer molla a tazza	2	51CrV4 Zinc Coated	AISI 316
13	stop device dispositivo di arresto	1	Cl. 8.8 Zinc Coated	AISI 316
14	antistatic device dispositivo antistatico	2	AISI 316	
15	stem O-ring O-ring stelo	1	VITON 90 sh. A AED	
16	body O-ring + BK O-ring corpo + BK	1	VITON 90 Sh. A AED + PTFE	

 Spares parts / Parti di ricambio

DIMENSIONS / DIMENSIONI

DN	15	20	25	40
ø"	½"	¾"	1"	1½"
ø E	14	19	24	38
L	216	229	254	305
M	275	275	275	380
H	102,5	102,5	102,5	125
h	75	75	75	104
P	55	55	55	65
f/t	16/10	16/10	16/10	22/14
Kg.	12	13	16	26
ISO 5211	F05	F05	F05	F07
ø F	M6	M6	M6	M8
ø G	50	50	50	70

Standard flange facing RJ / Finitura flange standard RJ

(P,T) DIAGRAMS / DIAGRAMMI (P,T)

DEVLON SEATS (PTFE+METAL CORE OPTIONAL) /
SEDI IN DEVLON (PTFE+AM SU RICHIESTA)

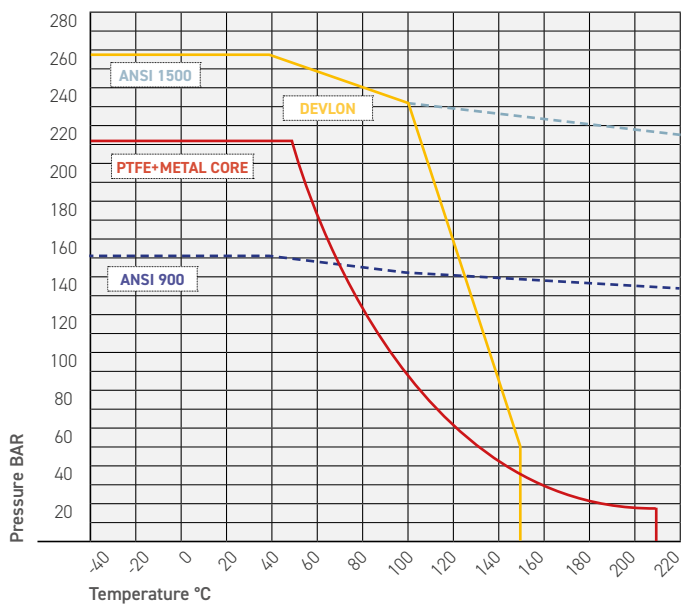

DEVLON SEATS

DN	All
P max @ Tmax	100 bar @ 160°C

PTFE+AM SEATS

DN	All
P max @ Tmax	15 bar @ 210°C



**ALFA 625
ANSI 2500**
Split body ball valve - Full bore

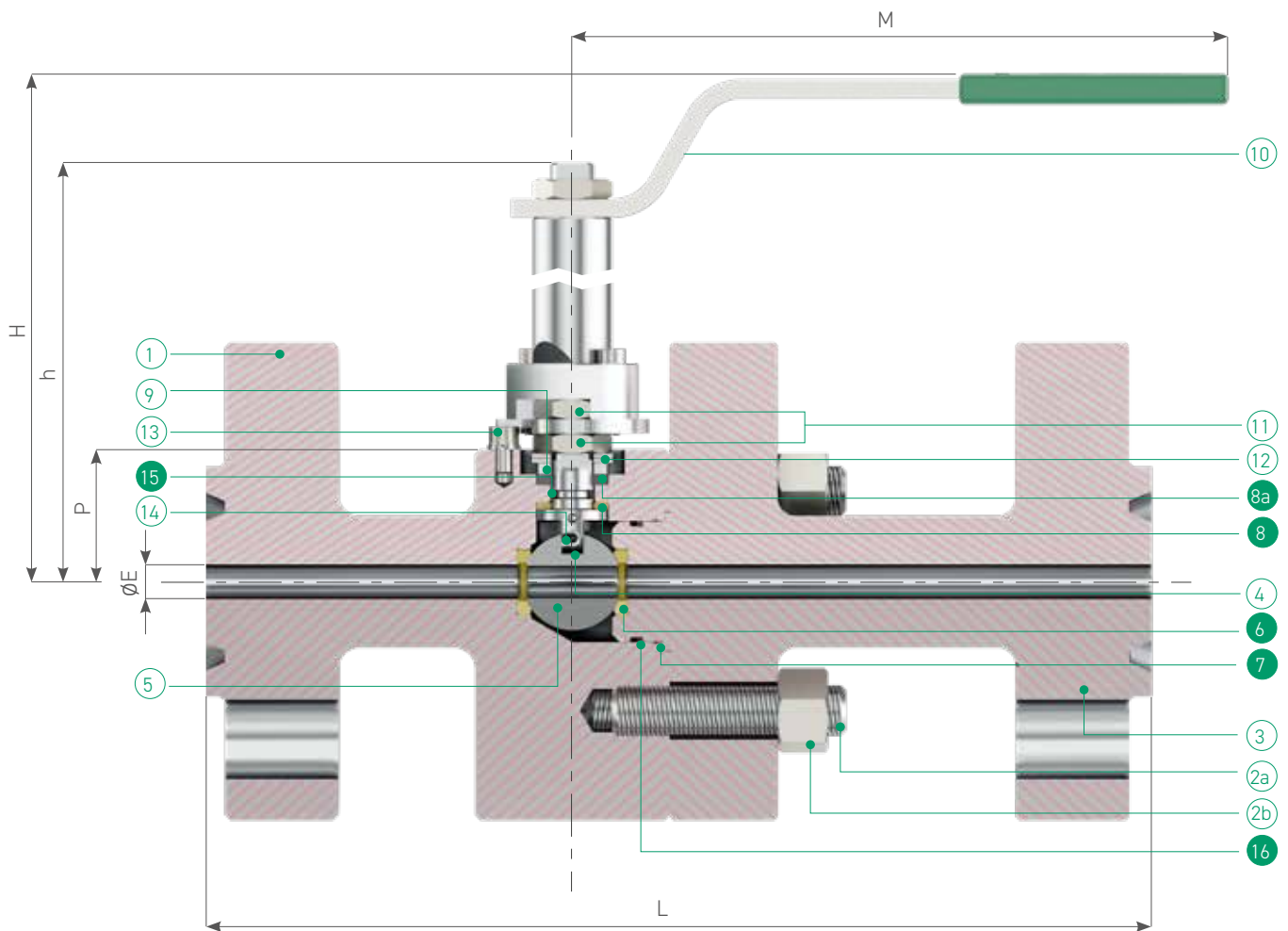

Actuator - valve coupling /
Accoppiamento valvola - attuatore
ISO 5211

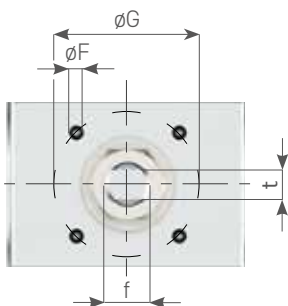

ALFA 625 ANSI 2500

Standard valve materials / Materiali costruzione valvola standard

PART NAME PARTICOLARE		Q.TY Q.TA	CARBON STEEL	STAINLESS STEEL
BAR STOCK BODY CORPO DA BARRA				
1	body corpo	1	ASTM A105N/LF2	ASTM A479 316/316L
2a	stud tirante	4/8	ASTM A193 B7	ASTM A193 B8M
2b	nut dado	4/8	ASTM A194 2H	ASTM A194 B8
3	closure chiusura	1	ASTM A105N/LF2	ASTM A479 316/316L
4	stem stelo	1	ASTM A182 F51	
5	ball sfera	1	ASTM A182 F51	
6	seats sedi	2	DEVLON	
7	1 st body gasket guarnizione corpo int.	1	P.T.F.E.	
8	washer bussola	1	DEVLON	
8a	stem gasket guarnizione stelo	2	GRAPHOIL	
9	gland premi-guarnizione	1	Carbon Steel Zinc Coated	Stainless Steel 316
10	lever leva	1	Carbon Steel Zinc Coated	
11	stem nut dado stelo	2	Cl. 8	A4-40 (AISI 316)
12	spring washer molla a tazza	2	51CrV4 Zinc Coated	AISI 316
13	stop device dispositivo di arresto	1	Cl. 8.8 Zinc Coated	AISI 316
14	antistatic device dispositivo antistatico	2	AISI 316	
15	stem O-ring O-ring stelo	1	VITON 90 sh. A AED	
16	body O-ring + BK O-ring corpo + BK	1	VITON 90 Sh. A AED + PTFE	

Spares parts / Parti di ricambio

DIMENSIONS / DIMENSIONI

DN	15	20	25	40
∅"	1/2"	3/4"	1"	1 1/2"
∅ E	11	14	19	29
L	264	273	308	384
M	180	180	275	380
H	189,5	189,5	171,5	204,5
h	56	56	66	94
P	37,5	37,5	48,5	61
f/t	12/8	12/8	16/10	22/14
Kg.	15	18	21	32
ISO 5211	F05	F05	F05	F07
∅ F	M6	M6	M6	M8
∅ G	50	50	50	70

Standard flange facing RJ / Finitura flange standard RJ

(P,T) DIAGRAMS / DIAGRAMMI (P,T)

DEVLON SEATS (PEEK ON REQUEST) /
SEDI IN DEVLON (PEEK SU RICHIESTA)

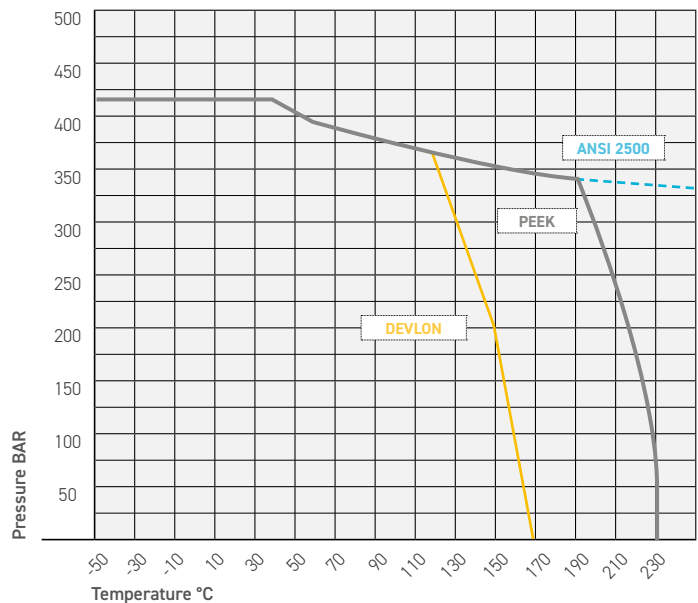

DEVLON SEATS

DN	All
P max @ Tmax	100 bar @ 160°C

PEEK SEATS

DN	All
P max @ Tmax	45 bar @ 230°C





ALFA 65/61/69

ANSI 150-300 | PN 10-40

Split body ball valve - Full bore

MAIN FEATURES / CARATTERISTICHE

- **Heating/cooling jacket integral to the valve body, applicable on flanged ball valves, both ANSI (ALFA 64 and 60) and PN (ALFA 68) only on stock bar executions.** / Camicia di riscaldamento/raffreddamento integrale, fornibile sia con valvola ANSI (ALFA 64 e 60) che PN (ALFA 68) solo da barra.
- **For application requiring a fixed fluid temperature inside the valve body, through circulation inside the jacket of hot water, steam, diathermic oil or other fluid** / Per applicazioni che necessitano il mantenimento di una temperatura del fluido di processo all'interno della valvola costante, mediante circolazione all'interno della camicia di acqua calda, vapore, olio diatermico o altro fluido.
- **Metal thickness / Spessore lamiera: 3 mm**
- **Jacket hollow space / Intercapedine camera: 10 mm**
- **Maximum operating jacket pressure / Pressione massima di funzionamento camicia: 16 bar**
- **Jacket material / Materiale camicia:**
Carbon steel type S235 JR (Carbon steel body valves) / Acciaio al carbonio S235 JR (Valvole acciaio al carbonio)
Pickled stainless steel AISI 316 (Stainless steel body valves) / Acciaio inossidabile AISI 316 decappato (Valvole acciaio inox)
- **100% hydraulic tested - welding process ASME qualified / Test idraulico al 100% - processo di saldatura qualificato ASME.**
- **For valve technical features, please refer to standard valve family / Per le caratteristiche costruttive delle valvole fare riferimento alle famiglie base.**
- **For different configuration type, number and position of jacket connection please contact our engineering dept / Per varianti su tipo, numero e posizione attacchi contattare l'ufficio tecnico.**

DIMENSIONS / DIMENSIONI

DN	15	20	25	32	40	50	65	80	100	125	150	200
ø"	½"	¾"	1"	1¼"	1½"	2"	2½"	3"	4"	5"	6"	8"
A	200	225	230	240	265	275	300	335	380	405	440	505
B	0	0	0	25	30	30	45	50	70	80	95	130
ø F	DN15						DN25					
ø m	ø ½"						ø 1					
PESO CAMICIA FILETTATA*	1,5	1,5	1,8	2,2	2,5	3	5	5	10	11	12	14
PESO CAMICIA FLANGIATA*	3,5	3,5	3,8	4,2	4,5	5	7	7	14	15	16	18

* To be added to main valve weight / Da aggiungere al peso della valvola base

**FLANGED CONNECTION / ATTACCO FLANGIATO
(EN1092-1 PN16, ANSI 150)**

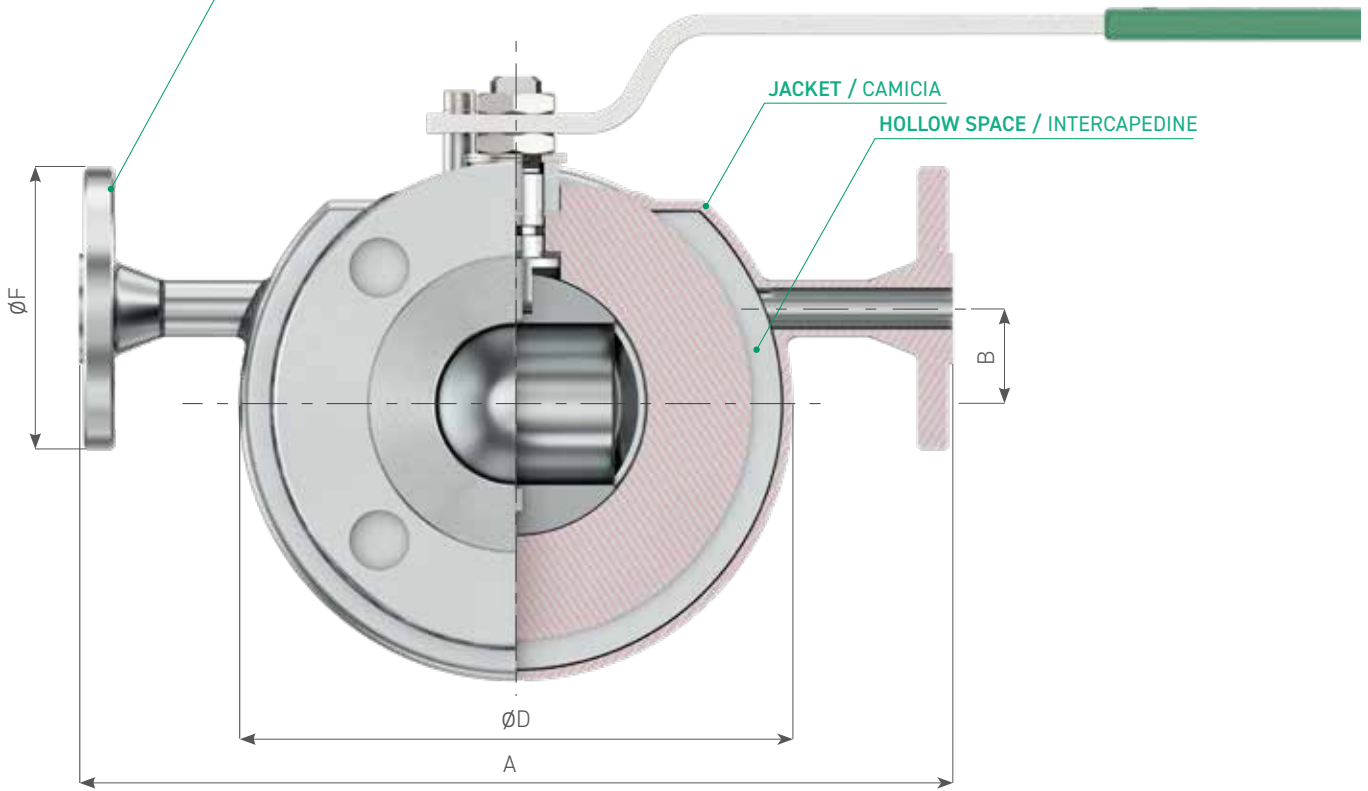

**THREADED CONNECTION / ATTACCO FILETTATO
(GAS-F ANSI B1.20.1)**

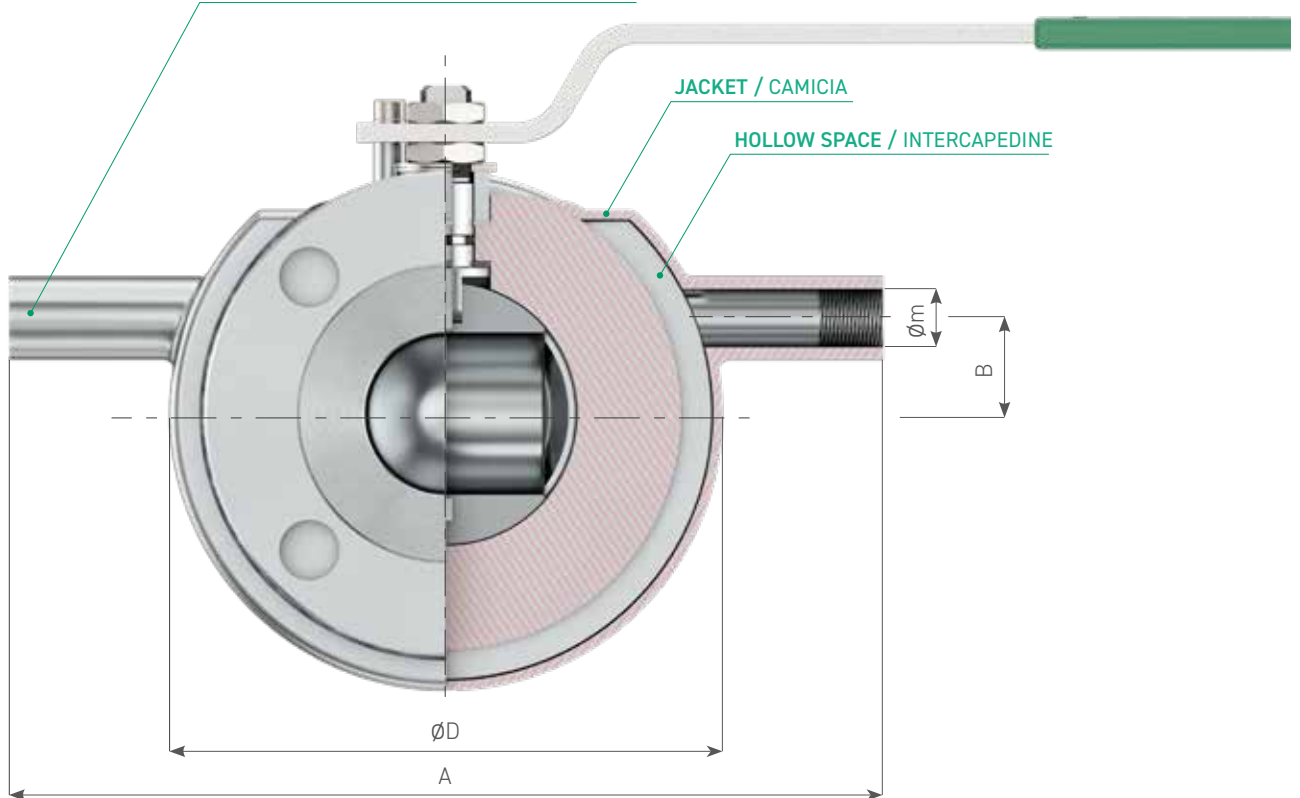

**ALFA 54
ANSI 150**
Split body ball valve - Reduced bore

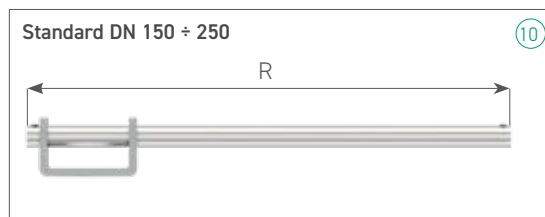
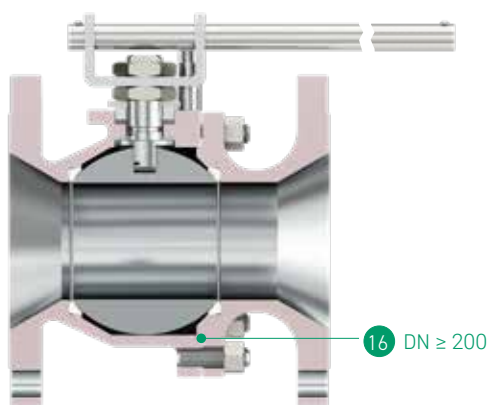
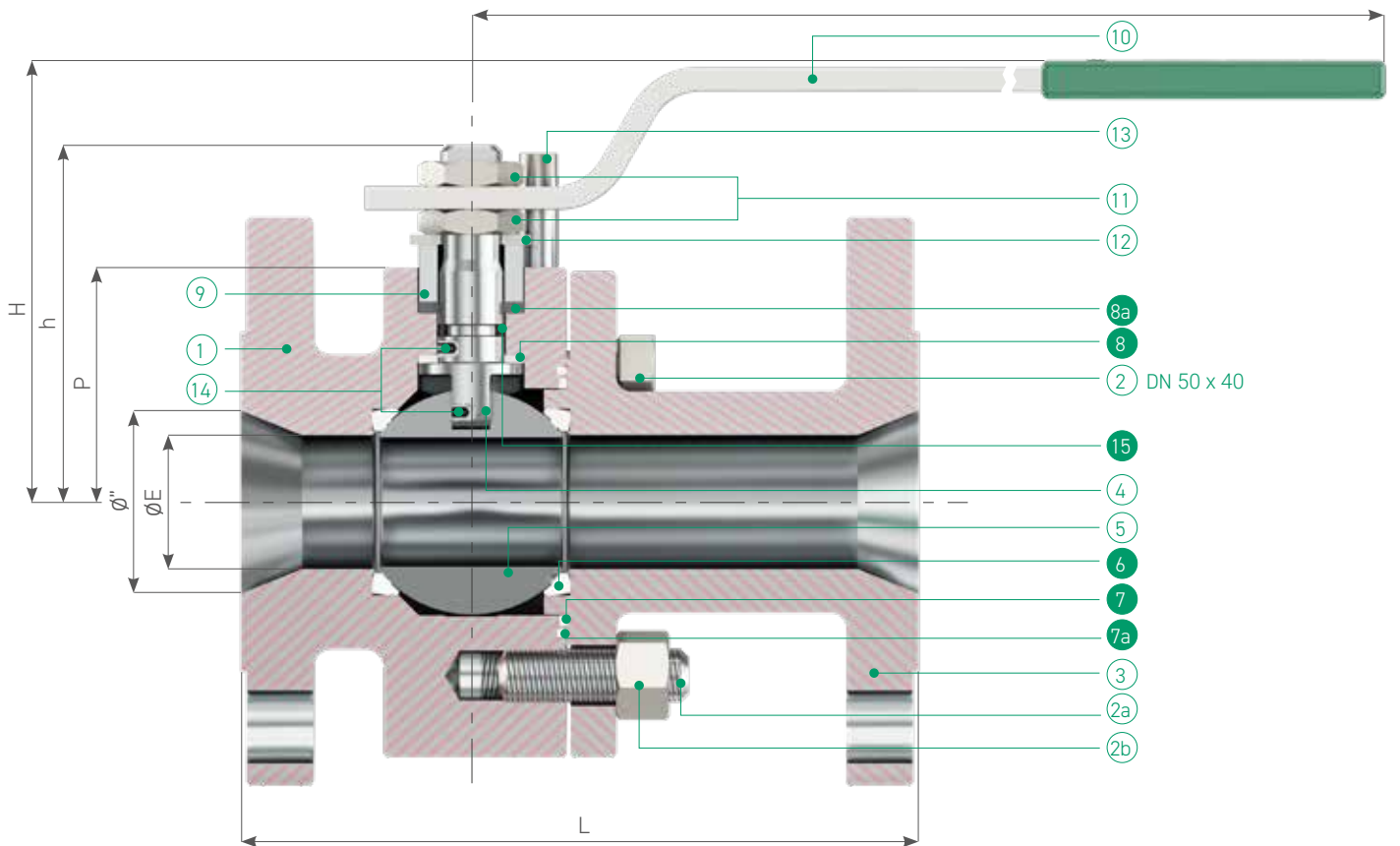
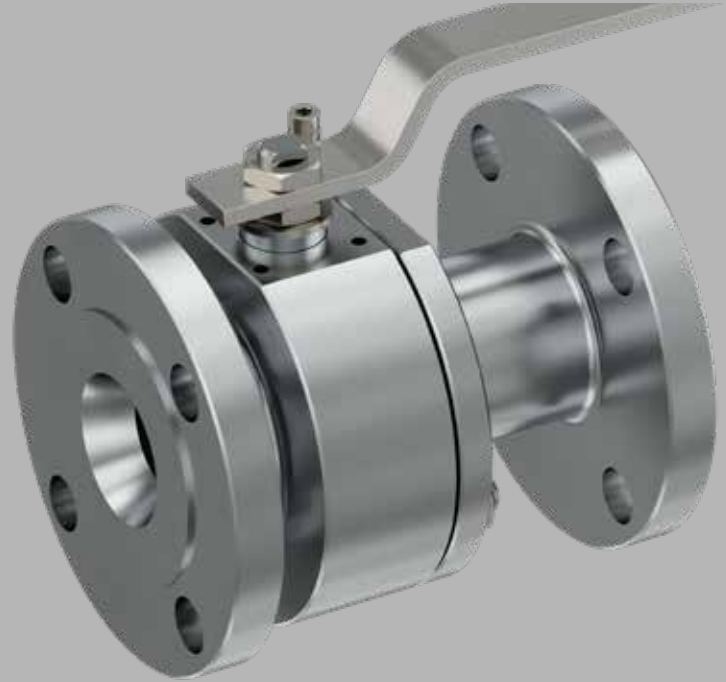

Actuator - valve coupling /
Accoppiamento valvola - attuatore
ISO 5211

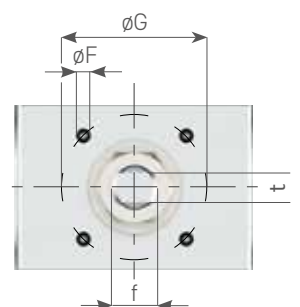

Standard valve materials / Materiali costruzione valvola standard

PART NAME PARTICOLARE		Q.TY Q.TA'	MATERIALS MATERIALI			
		CARBON STEEL		STAINLESS STEEL		
		BAR STOCK BODY CORPO DA BARRA	INVESTMENT CASTING BODY CORPO DA FUSIONE	BAR STOCK BODY CORPO DA BARRA	INVESTMENT CASTING BODY CORPO DA FUSIONE	
1	body corpo	1	ASTM A105N/LF2	ASTM A216 WCB	ASTM A479 316/316L	ASTM A351 CF8M
2	screw vite	4	ASTM A193 B7 (DN 50)		ASTM A193 B8M (DN 50)	
2a	stud tirante	4/8	ASTM A193 B7		ASTM A193 B8M	
2b	nut dado	4/8	ASTM A194 2H		ASTM A194 B8	
3	closure chiusura	1	ASTM A105N/LF2	ASTM A216 WCB	ASTM A479 316/316L	ASTM A351 CF8M
4	stem stelo	1	ASTM A479 F6a (AISI 410)		ASTM A182 316/316L	
5	ball sfera	1	ASTM A351 CF8		ASTM A351 CF8M	
6	seats sedi	2	TFM	TFM (PTFE + A.M. : DN 250x175)	TFM	TFM (PTFE + A.M. : DN 250x175)
7	1 st body gasket guarnizione corpo int.	1	P.T.F.E.	P.T.F.E. (DN ≤ 100 x 80)	P.T.F.E.	P.T.F.E. (DN ≤ 100 x 80)
7a	2 nd body gasket guarnizione corpo est.	1	GRAPHOIL			
8	washer bussola	1	P.T.F.E.			
8a	stem gasket guarnizione stelo	2	GRAPHOIL			
9	gland premi-guarnizione	1	Carbon Steel Zinc Coated		Stainless steel 316	
10	lever leva	1	Carbon Steel Zinc Coated			
11	stem nut dado stelo	2	Cl. 8		A4-40 (AISI 316)	
12	spring washer molla a tazza	2	51CrV4 Zinc Coated		AISI 316	
13	stop device dispositivo di arresto	1	Cl.8.8 Zinc Coated		AISI 316	
14	antistatic device dispositivo antistatico	2	AISI 316			
15	stem O-ring O-ring stelo	1	VITON 75 Sh. A			
16	body O-ring O-ring corpo	1	N.A.	P.T.F.E. (DN ≥ 125 x 100)	N.A.	P.T.F.E. (DN ≥ 125 x 100)

 Spares parts / Parti di ricambio

DIMENSIONS / DIMENSIONI

DN	50x40	65x50	80x65	100x80	150x100	200x150	250x175
∅"	2"x1½"	2½"x2"	3"x2½"	4"x3"	6"x4"	8"x6"	10"x7"
∅ E	38	51	64	76	102	152	180
L	178	190	203	229	267*	292*	330*
M/R	275/-	275/-	380/-	380/-	440/500	-/800	-/800
H	118	126	143	149	191	273	300
h	95	103	122	127	157	218	242
P	63	68,5	82	88,5	111	153	179
f/t	16/10	16/10	22/14	22/14	30/18	45/30	45/30
Kg. (1)/(2)	13/-	17/12	26/19	34/28	58/43	95/68	157/108
ISO 5211	F05	F05	F07	F07	F10	F14	F14
∅ F	M6	M6	M8	M8	M10	M16	M16
∅ G	50	50	70	70	102	140	140

* short pattern valve; long pattern, on request / valvola a scartamento ridotto; scartamento normale, su richiesta



**ALFA 50
ANSI 300**
Split body ball valve - Reduced bore

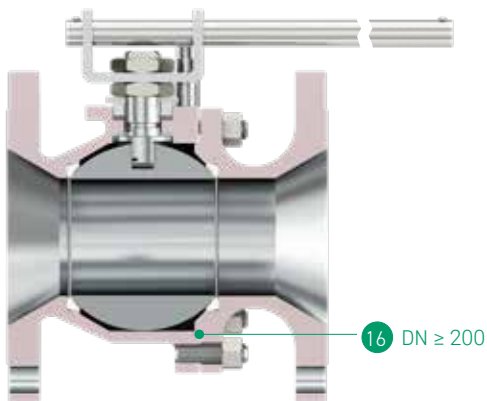
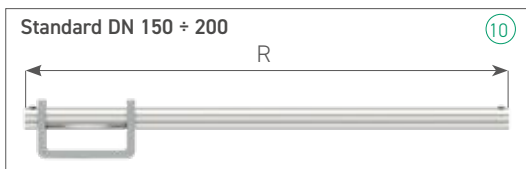
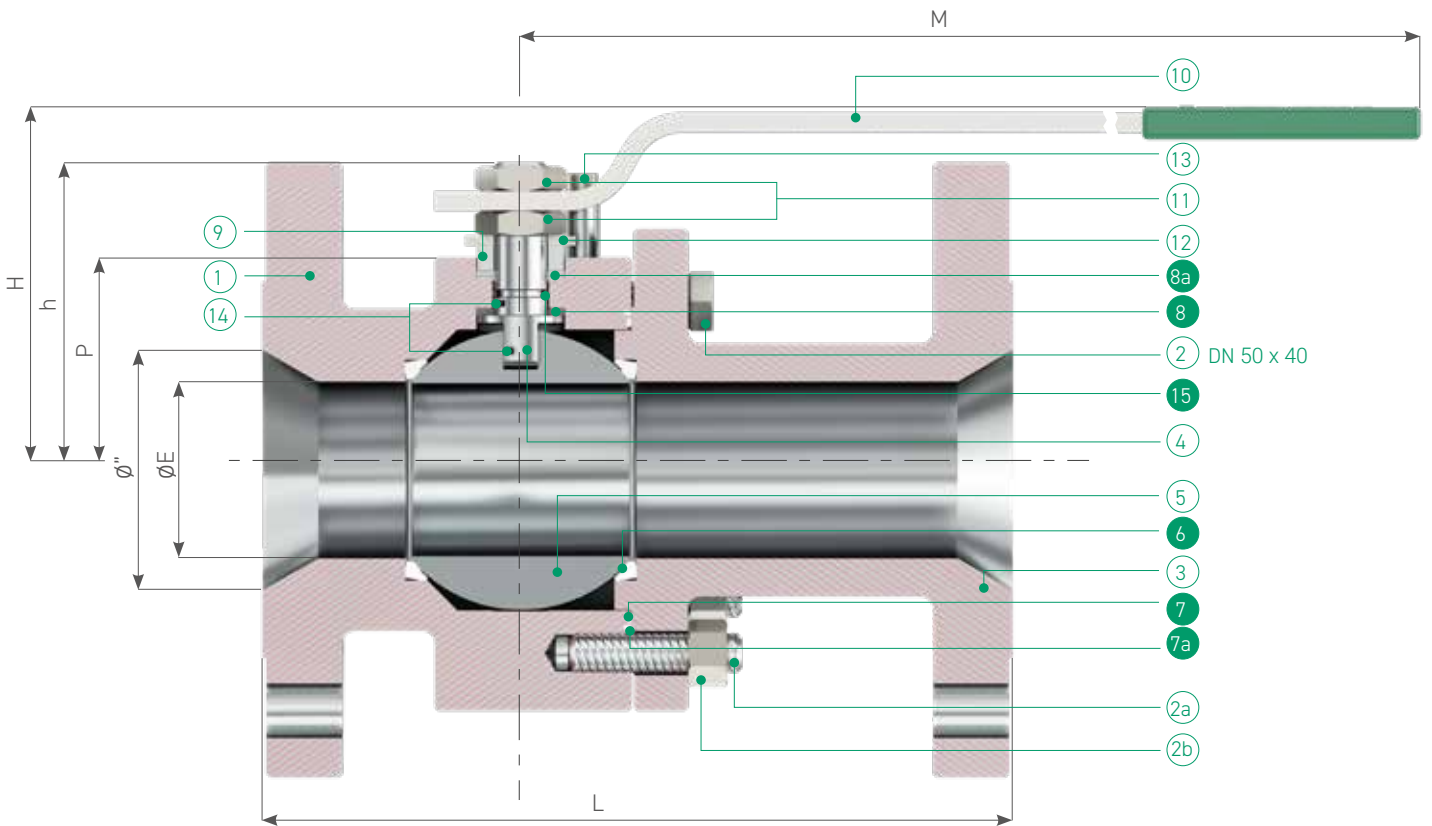
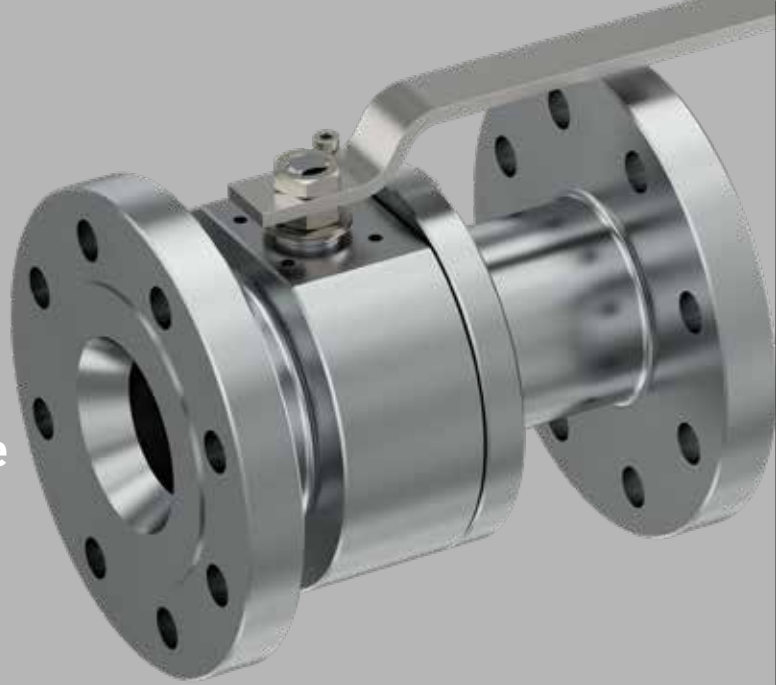

Handwheel gearbox /
Riduttore con volantino
Standard DN 250



Actuator - valve coupling /
Accoppiamento valvola - attuatore
ISO 5211

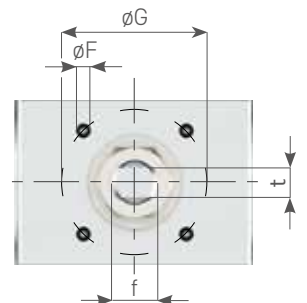

Standard valve materials / Materiali costruzione valvola standard

PART NAME PARTICOLARE		Q.TY Q.TA'	MATERIALS MATERIALI			
		CARBON STEEL			STAINLESS STEEL	
		BAR STOCK BODY CORPO DA BARRA	INVESTMENT CASTING BODY CORPO DA FUSIONE	BAR STOCK BODY CORPO DA BARRA	INVESTMENT CASTING BODY CORPO DA FUSIONE	
1	body corpo	1	ASTM A105N/LF2	ASTM A216 WCB	ASTM A479 316/316L	ASTM A351 CF8M
2	screw vite	4	ASTM A193 B7 (DN 50x40)		ASTM A193 B8M (DN 50x40)	
2a	stud tirante	4/8	ASTM A193 B7		ASTM A193 B8M	
2b	nut dado	4/8	ASTM A194 2H		ASTM A194 B8	
3	closure chiusura	1	ASTM A105N/LF2	ASTM A216 WCB	ASTM A479 316/316L	ASTM A351 CF8M
4	stem stelo	1	ASTM A479 F6a (AISI 410)		ASTM A182 316/316L	
5	ball sfera	1	ASTM A351 CF8		ASTM A351 CF8M	
6	seats sedi	2	TFM	TFM/PTFE +AM (DN 200x150)	TFM	TFM/PTFE +AM (DN 200x150)
7	1 st body gasket guarnizione corpo int.	1	P.T.F.E.	P.T.F.E. (DN ≤ 100x80)	P.T.F.E.	P.T.F.E. (DN ≤ 100x80)
7a	2 nd body gasket guarnizione corpo est.	1	GRAPHOIL			
8	washer bussola	1	P.T.F.E.			
8a	stem gasket guarnizione stelo	2	GRAPHOIL			
9	gland preguarnizione	1	Carbon Steel Zinc Coated		Stainless steel 316	
10	lever leva	1	Carbon Steel Zinc Coated			
11	stem nut dado stelo	2	Cl. 8		A4-40 (AISI 316)	
12	spring washer molla a tazza	2	51CrV4 Zinc Coated		AISI 316	
13	stop device dispositivo di arresto	1	Cl.8.8 Zinc Coated		AISI 316	
14	antistatic device dispositivo antistatico	2	AISI 316			
15	stem O-ring O-ring stelo	1	VITON 75 Sh. A			
16	body O-ring O-ring corpo	1	N.A.	P.T.F.E. (DN ≥ 150x100)	N.A.	P.T.F.E. (DN ≥ 150x100)

 Spares parts / Parti di ricambio

DIMENSIONS / DIMENSIONI

DN	50x40	65x50	80x65	100x80	150x100	200x150
ø"	2"x 1½"	2½"x2"	3"x2½"	4"x3"	6"x4"	8"x6"
ø E	38	51	64	76	102	152
L	216	241	283	305	403	419 *
M/R	275/-	275/-	380/-	380/-	440/500	*
H	118	126	143	149	191	273
h	95	103	122	127	157	218
P	63	68,5	82	88,5	111	153
f/t	16/10	16/10	22/14	22/14	30/18	45/30
Kg. (1)/(2)	17/-	22,5/19	35/25	48/36	90/67	147/105
ISO 5211	F05	F05	F07	F07	F10	F14
ø F	M6	M6	M8	M8	M10	M16
ø G	50	50	70	70	102	140

* Short pattern valve; long pattern, on request / Valvola a scartamento ridotto; scartamento normale, su richiesta

* Available with handwheel gearbox only / Disponibile solo con riduttore manuale



**ALFA 506
ANSI 600**
Split body ball valve - Reduced bore

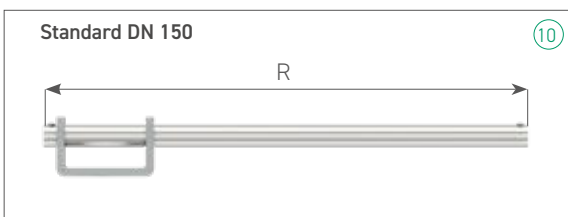
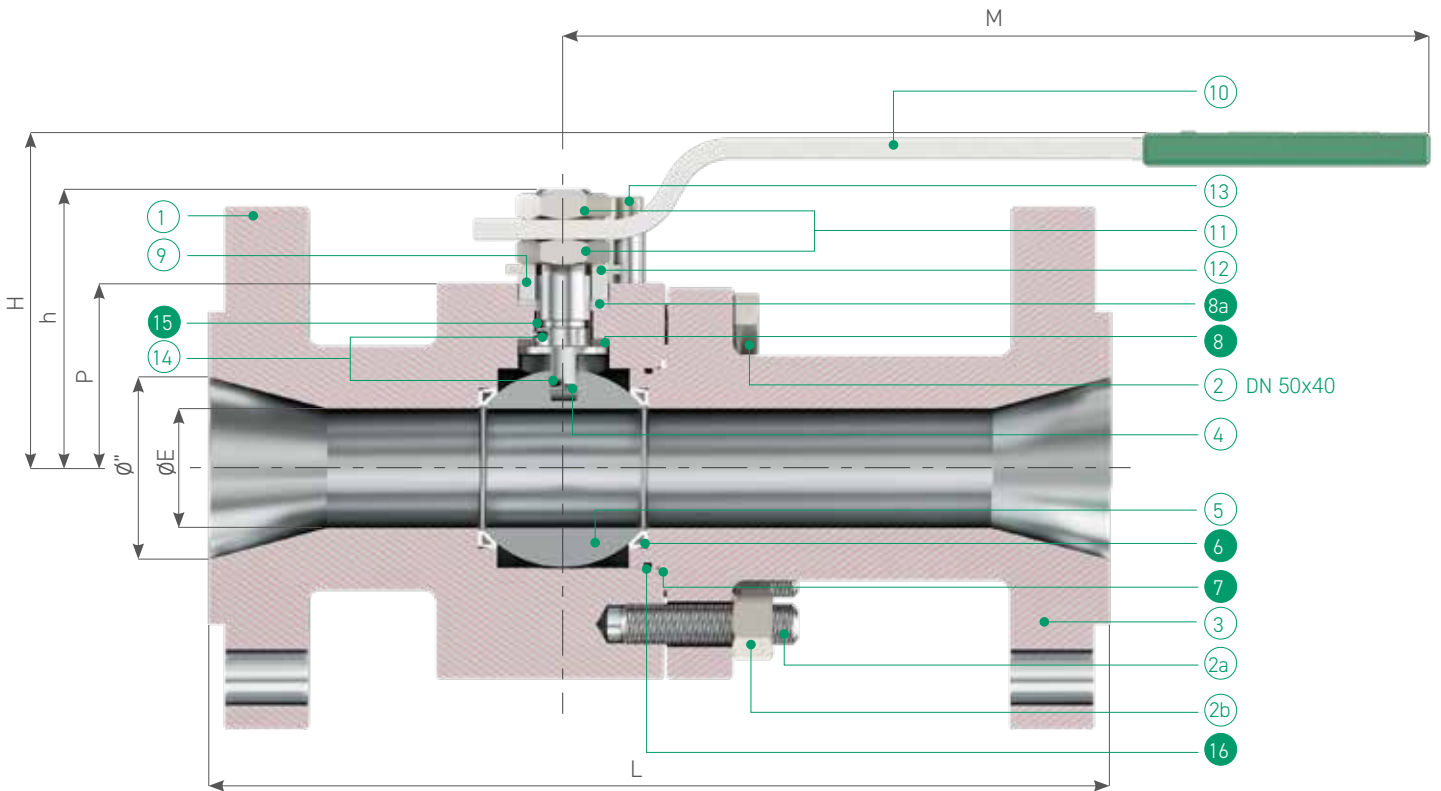

Actuator - valve coupling /
Accoppiamento valvola - attuatore
ISO 5211

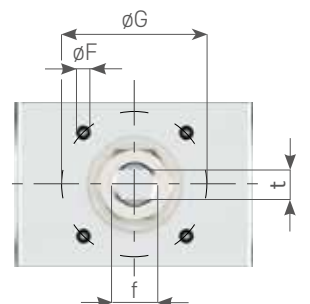

ALFA 506 ANSI 600

Standard valve materials / Materiali costruzione valvola standard

PART NAME PARTICOLARE		Q.TY Q.TA	CARBON STEEL	STAINLESS STEEL
BAR STOCK BODY CORPO DA BARRA				
1	body corpo	1	ASTM A105N/LF2	ASTM A479 316/316L
2	screw vite	4	ASTM A193 B7 (DN ≤ 40)	ASTM A193 B8M (DN ≤ 40)
2a	stud tirante	4/8	ASTM A193 B7	ASTM A193 B8M
2b	nut dado	4/8	ASTM A194 2H	ASTM A194 B8
3	closure chiusura	1	ASTM A105N/LF2	ASTM A479 316/316L
4	stem stelo	1	ASTM A182 F51	
5	ball sfera	1	ASTM A351 CF8	ASTM A351 CF8M
6	seats sedi	2	TFM / PTFE + AM (DN ≥ 50x40)	
7	1 st body gasket guarnizione corpo int.	1	P.T.F.E. (DN ≤ 100x80)	
7a	2 nd body gasket guarnizione corpo est.	1	GRAPHOIL	
8	washer bussola	1	P.T.F.E.	
8a	stem gasket guarnizione stelo	2	GRAPHOIL	
9	gland premi-guarnizione	1	Carbon Steel Zinc Coated	Stainless Steel 316
10	lever leva	1	Carbon Steel Zinc Coated	
11	stem nut dado stelo	2	Cl. 8	A4-40 (AISI 316)
12	spring washer molla a tazza	2	51CrV4 Zinc Coated	AISI 316
13	stop device dispositivo di arresto	1	Cl. 8.8 Zinc Coated	AISI 316
14	antistatic device dispositivo antistatico	2	AISI 316	
15	stem O-ring O-ring stelo	1	VITON 90 sh. A AED	
16	body O-ring O-ring corpo	1	P.T.F.E. (DN ≥ 50x40)	

 Spares parts / Parti di ricambio

DIMENSIONS / DIMENSIONI

DN	50	80	100	150
∅"	2"	3"	4"	6"
∅ E	38	64	76	102
L	292	356	432	559
M/R	380/-	380/-	440/500	-/800
H	125	146	174	236
h	104	115	141	181
P	65	75	95	124
f/t	22/14	22/14	30/18	45/30
Kg.	19	41	71,5	120
ISO 5211	F07	F07	F10	F14
∅ F	M8	M8	M10	M16
∅ G	70	70	102	140

(P,T) DIAGRAMS / DIAGRAMMI (P,T)

TFM/PTFE + METAL CORE / SEDI IN TFM/PTFE + AM

1/2" ≤ DN ≤ 4"

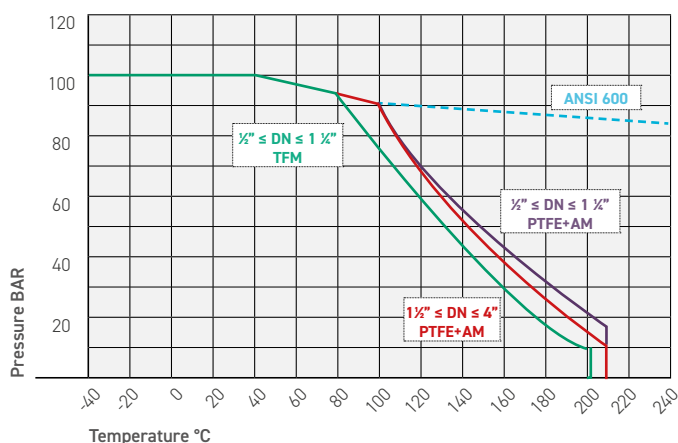

Select 1 size lower (es. for DN 50 select DN 40) / Selezionare una taglia inferiore a quella desiderata (ad esempio: per DN 50 analizzare dati DN 40)

DN	1/2" ≤ DN ≤ 1 1/2" (15 ≤ DN ≤ 50)
P max @ Tmax	6,5 bar @ 200°C (TFM SEATS) 10 bar @ 210°C (PTFE + AM SEATS)

DN	1 1/2" ≤ DN ≤ 4" (65 ≤ DN ≤ 100)
P max @ Tmax	9 bar @ 210°C (PTFE + AM SEATS)



(P,T) DIAGRAMS

Diagrammi (P,T)

ALFA SERIE 5/6

Pressure - temperature diagrams shows the standard working condition (pressure & temperature) for the specific valve. These conditions refer to a continuous use. For transitions for peak condition, an overload until 10% is accepted. In these cases we suggest anyway to contact engineering dept.

I diagrammi pressione - temperatura identificano le condizioni di uso contemporanee di pressione e temperatura a cui la valvola può operare. Tali condizioni sono da riferirsi ad un uso continuo. Per condizioni transitorie o di picco, scostamenti fino al 10% sono tollerati. In tali casistiche consultare comunque l'ufficio tecnico Alfa Valvole.

TFM SEATS / SEDI IN TFM



MAIN FEATURES / CARATTERISTICHE

- **PTFE reinforced at molecular stage** / PTFE rinforzato a livello molecolare
- **Chemical optimized structure guarantees a constant response in continuous service until 200°C** / La struttura chimica ottimizzata garantisce performances stabili in servizio continuo fino a 200°C
- **Lubricating properties, dimensional stability and chemical compatibility equal to virgin PTFE** / Potere lubrificante, stabilità dimensionale e compatibilità chimica del PTFE
- **Mechanical and wear resistance equal to reinforced PTFE** / Resistenza meccanica e all'usura del PTFE

ALFAGRAPH SEATS / SEDI IN ALFAGRAPH



MAIN FEATURES / CARATTERISTICHE

- **Company owned compound: PTFE + CARBON + GRAPHITE** / Miscela proprietaria: PTFE + CARBONE + VETRO + GRAFITE
- **Increased pressure resistance at high temperature thanks to the carbon filling** / Incremento della resistenza alla pressione alle alte temperature grazie all'addizione di carbone
- **Less deformation under load thanks to the glass filling** / Minore deformazione sotto carico grazie all'addizione di vetro
- **Better operating torque control thanks to lubricating power of graphite filling** / Coppie sotto controllo grazie al potere lubrificante della grafite

PTFE SEATS + METAL CORE / SEDI IN PTFE + AM



MAIN FEATURES / CARATTERISTICHE

- **PTFE enclosure with metal core in AISI 316** / PTFE con inserto metallico in AISI 316
- **Better performances at temperature until 210° C thanks to metal core** / Il nucleo metallico garantisce ottime performances a temperature fino a 210° C e ad alte pressioni
- **Chemical compatibility thanks to PTFE enclosure** / La capsula in PTFE garantisce compatibilità chimica
- **Increased dimensional stability thanks to an optimized production process** / Incrementata stabilità dimensionale grazie al processo di produzione della sede

DEVLON SEATS / SEDI IN DEVLON



MAIN FEATURES / CARATTERISTICHE

- **Polyamide based polymer with increased working range compared to nylon and TFM** / Polimero a base poliammide con range di utilizzo maggiore di nylon e TFM
- **Working temperature range from -50°C until 176°C, pressure until 420 Bar** / Utilizzabile in range di temperatura da -50°C a +176°C e pressioni fino a 420 Bar
- **Working superior dimensional stability over PTFE/TFM in high pressure applications** / Superiore stabilità dimensionale rispetto al PTFE/TFM
- **Exceptional resistance to wear and abrasion** / Eccezionale resistenza a usura e abrasione
- **Lower frictional losses than Peek seats (lower operating torques)** / Minore coefficiente di attrito rispetto al Peek (coppie valvola inferiori)
- **Using Devlon seats increases torque about of 30% compared to TFM** / Il montaggio di sedi in Devlon aumenta le coppie valvola di circa il 30% rispetto al TFM





TFM SEATS /SEDI IN TFM (STANDARD EXECUTION)

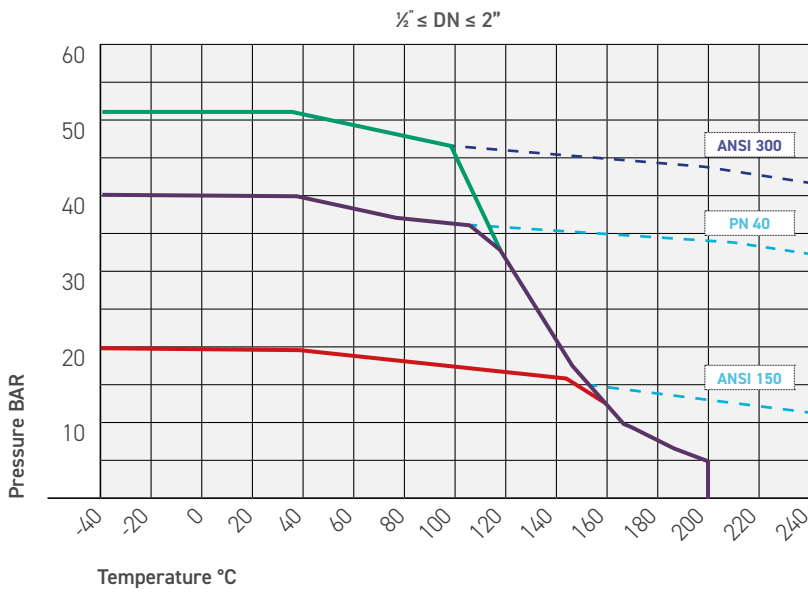

- ALFA 64/54*/65
- ALFA 68/69
- ALFA 60/50*/61

DN	$\frac{1}{2}'' \leq DN \leq 2''$ (15 ≤ DN ≤ 50)
P max @ Tmax	6,5 bar @ 200°C

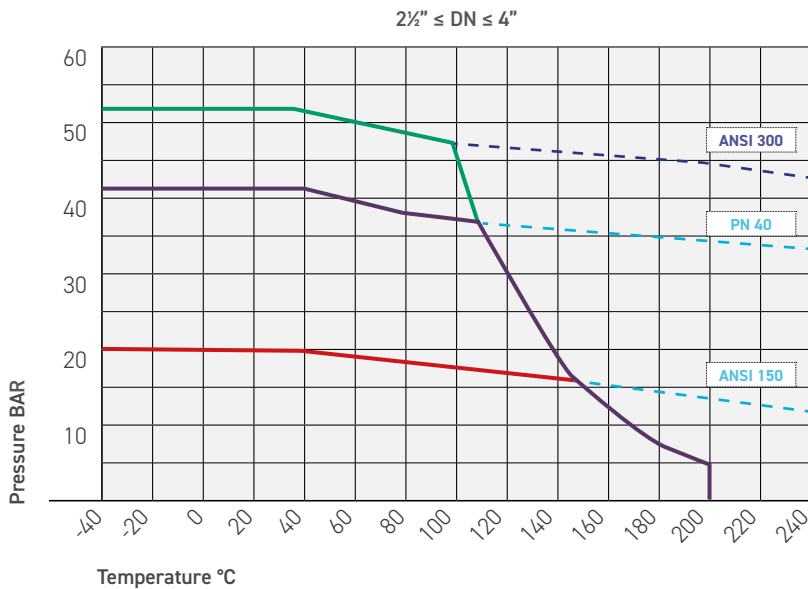

DN	$2\frac{1}{2}'' \leq DN \leq 4''$ (65 ≤ DN ≤ 100)
P max @ Tmax	5,5 bar @ 200°C

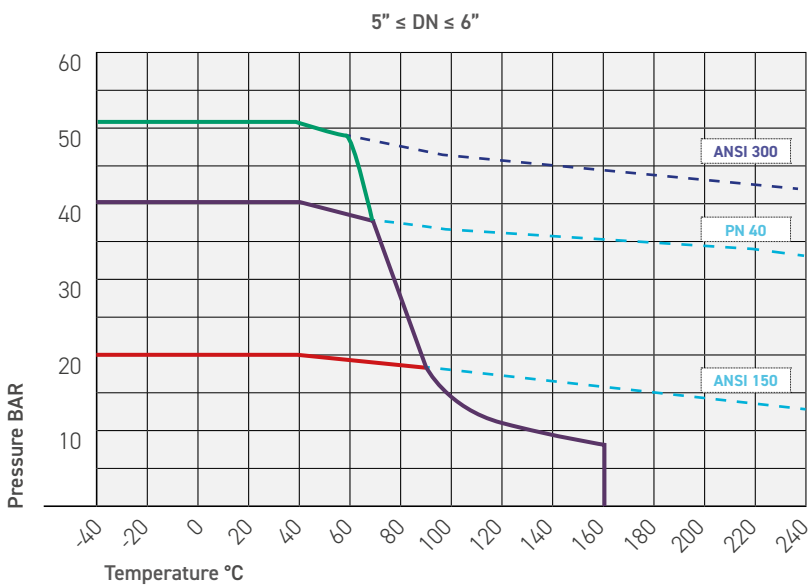

DN	$5'' \leq DN \leq 6''$ (125 ≤ DN ≤ 150)
P max @ Tmax	8 bar @ 160°C

* Select 1 size lower (es. for DN 50 select DN 40) / Selezionare una taglia inferiore a quella desiderata (ad esempio: per DN 50 analizzare dati DN 40)



ALFAGRAPH SEATS / SEDI IN ALFAGRAPH (ON REQUEST)

$\frac{1}{2}'' \leq DN \leq 2''$

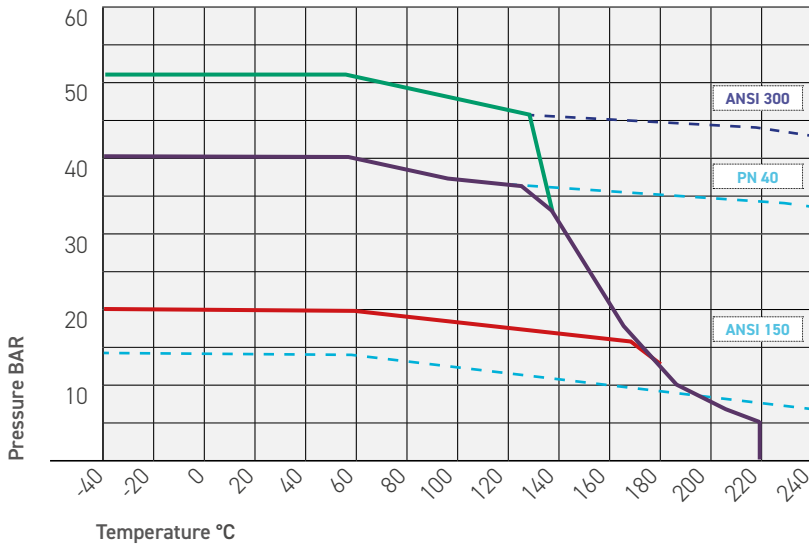

- ALFA 64/54*/65
- ALFA 68/69
- ALFA 60/50*/61

DN	$\frac{1}{2}'' \leq DN \leq 2''$ (15 ≤ DN ≤ 50)
P max @ Tmax	5 bar @ 220°C

$2\frac{1}{2}'' \leq DN \leq 4''$

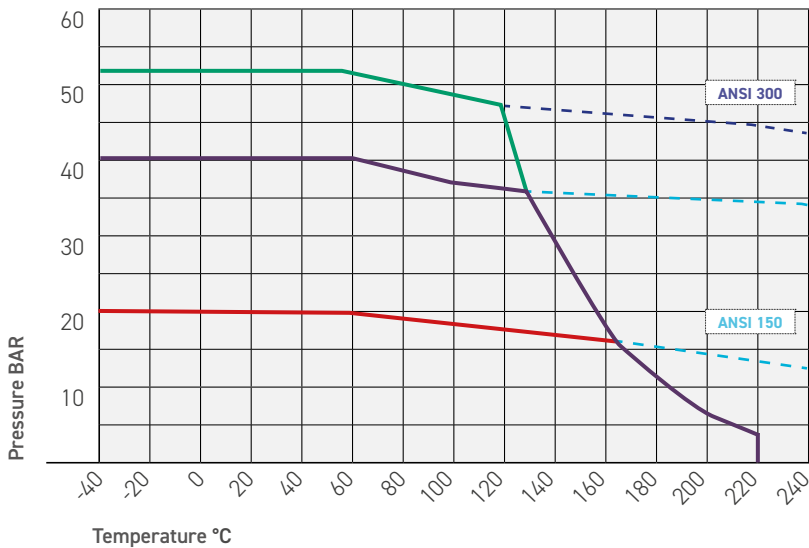

DN	$2\frac{1}{2}'' \leq DN \leq 4''$ (65 ≤ DN ≤ 100)
P max @ Tmax	4 bar @ 220°C

$5'' \leq DN \leq 6''$

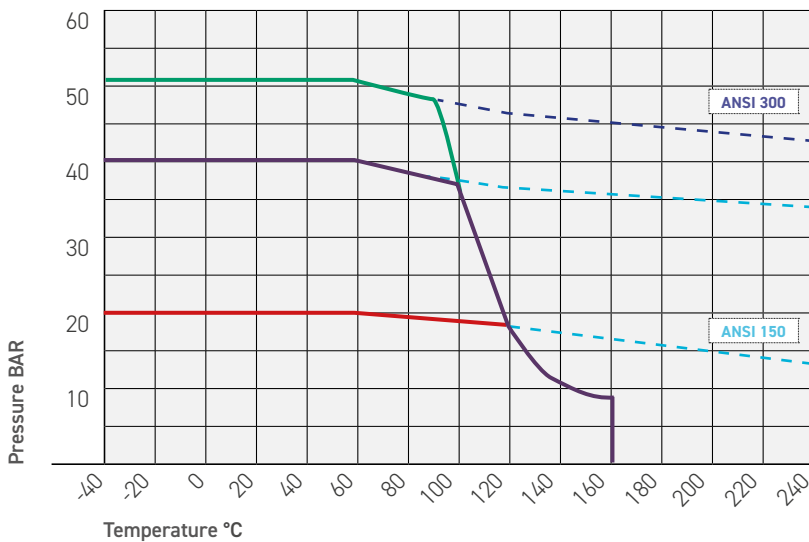

DN	$5'' \leq DN \leq 6''$ (125 ≤ DN ≤ 150)
P max @ Tmax	8 bar @ 160°C

* Select 1 size lower (es. for DN 50 select DN 40) / Selezionare una taglia inferiore a quella desiderata (ad esempio: per DN 50 analizzare dati DN 40)





PTFE SEATS + METAL CORE / SEDI IN PTFE + AM (ON REQUEST)

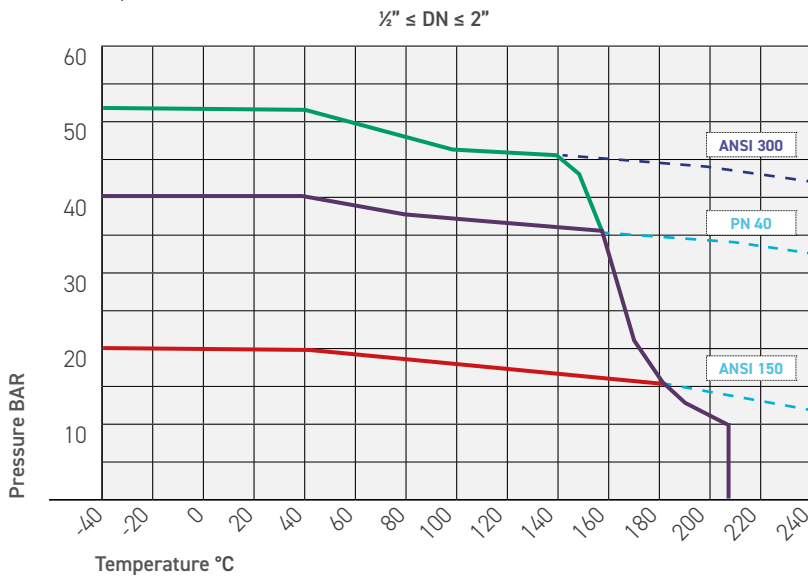

- ALFA 64/54*/65
- ALFA 68/69
- ALFA 60/50*/61

DN	$\frac{1}{2}'' \leq DN \leq 2''$ (15 ≤ DN ≤ 50)
P max @ Tmax	10 bar @ 210°C

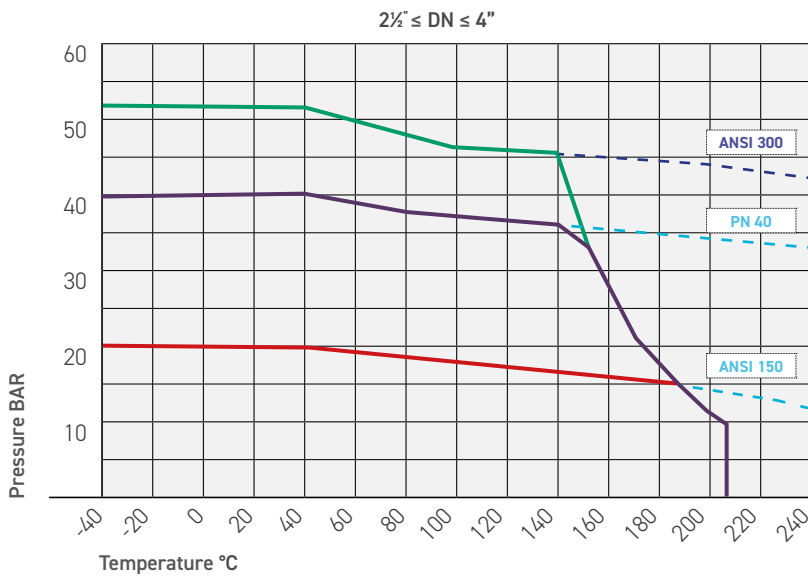

DN	$2\frac{1}{2}'' \leq DN \leq 4''$ (65 ≤ DN ≤ 100)
P max @ Tmax	9 bar @ 210°C

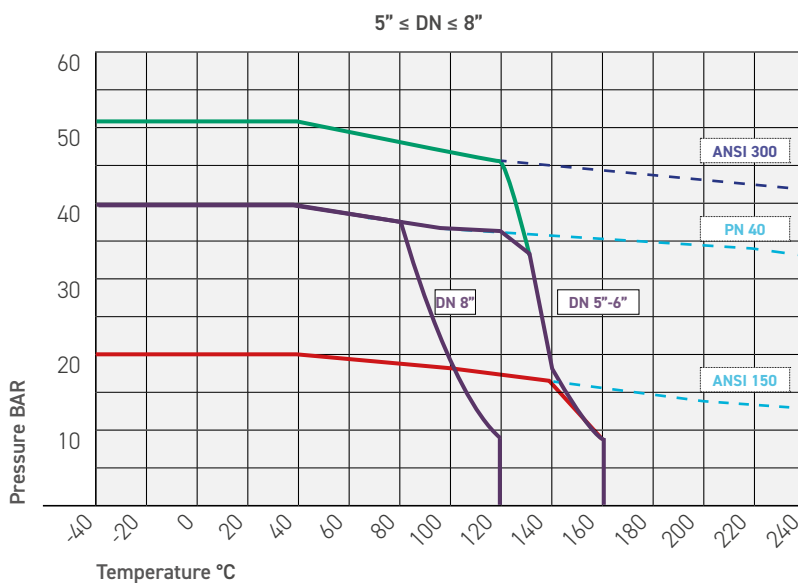

DN	$5'' \leq DN \leq 8''$ (125 ≤ DN ≤ 200)
P max @ Tmax	8 bar @ 160°C (DN 125-150) 8 bar @ 120°C (DN 200)

* Select 1 size lower (es. for DN 50 select DN 40) / Selezionare una taglia inferiore a quella desiderata (ad esempio: per DN 50 analizzare dati DN 40)

TYPE APPROVAL TESTING

Prove di tipo



1. Cryogenic testing according: / Test criogenico in accordo alla normativa: Shell MESC SPE 77/200
2. Fire safe testing for valve ALFA 64 according: / Test Fire Safe su valvola ALFA 64 in accordo alla normativa: API 6FA/API 607 & ISO 10497

According to specific customer requirements, following different product configurations in terms of body material, seat and gasket configuration and design, Alfa Valvole is able to perform functional and type tests both Cryogenic (-196°C) and Fire Safe resistance, cooperating with specialized laboratories and notified bodies.

These test allows to validate the product design consistence, his reliability and safety in case of extreme usage conditions or in case of catastrophic events, and over than this to satisfy all requirements coming from existing regulations.

In accordo ai requisiti richiesti dai clienti, sulla base delle differenti configurazioni e varianti di materiali corpo, sedi e guarnizioni, Alfa Valvole effettua test funzionali e di tipo criogenico (-196°C) e Fire Safe in collaborazione con laboratori specializzati ed enti notificati.

Tali test permettono di validare la bontà costruttiva del prodotto, la sua affidabilità e sicurezza in caso di condizioni di utilizzo estreme o in caso di eventi specifici, e soprattutto di soddisfare i requisiti specificati dalle normative cogenti.

FLANGE FACING OPTIONS

Opzioni finitura flange

	DN	ANSI 150 (A64/A54)		ANSI 300 (A60/A50)		ANSI 600 (A606/A506)	ANSI 900/1500 (A609/A615)	ANSI 2500 (A625)		
		FUSO/ CASTING	BARRA/ BAR STOCK	FUSO/ CASTING	BARRA/ BAR STOCK	BARRA/ BAR STOCK	BARRA/ BAR STOCK	BARRA/ BAR STOCK		
ANSI	RING JOINT	15					STD	STD		
		20					STD	STD		
		25					STD	STD		
		32					STD	STD		
		40					STD	STD		
		50								
		65								
		80								
		100								
		125								
		150								
		200								
		ANSI	LT (LARGE TONGUE) LG (LARGE GROOVE) LM (LARGE MALE) LF (LARGE FEMALE)	15	NOT APPLICABLE ON ANSI 150					
				20						
25										
32										
40										
50										
65										
80										
100										
125										
150										
200										

→ Options for flange finish according to ANSI B16.5 / Opzioni finitura flange in accordo a ANSI B16.5

→ All the flange finish modify the face to face dimensions / Tutte le finiture flange modificano lo scartamento della valvola

	DN	A68			
		FUSO/ CASTING	BARRA/ BAR STOCK		
PN	TYPE-C (TONGUE) TYPE-D (GROOVE) TYPE-E (SPIGOT) TYPE-F (RECESS)	15			
		20			
		25			
		32			
		40			
		50			
		65			
		80			
		100			
		125			
		150			
		200			
		PN	PN 06 DRILLING	15	
				20	
25					
32					
40					
50					
65					
80					
100					
125					
150					
200					

→ Options for flange finish according to ANSI B16.5 / Opzioni finitura flange in accordo a ANSI B16.5

OPTIONAL EXECUTIONS

Esecuzioni optional



BALANCE HOLE / FORO DI EQUILIBRIO

Balancing hole between ball cavity and upstream pipeline that avoid overpressures. Valve became unidirectional / Equilibra la pressione tra cavità sfera e tubazione a monte, eliminando sovrappressioni. Rende la valvola monodirezionale

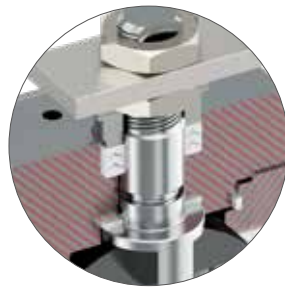

CHEVRON RING / PACCO A V

V-Shaped 3 pieces gasket: guarantees maximum tightness from stem area, suitable for every fluid and for vacuum conditions / Tripla guarnizione in PTFE sagomata che garantisce massima tenuta del premistoppa, adatta ad ogni fluido e a condizioni di vuoto



LEVER EXTENSION / ESTENSIONE LEVA

Lever extension suitable to operate the valve with insulation coverage / Estensione leva che permette di manovrare la valvola in caso di coibentazione



DOUBLE SEALING EXTENSION / PROLUNGA DOPPIA TENUTA

Extension (100mm) featured by additional gasket kit featured to have double sealing from stem area / Prolunga dotata di set di guarnizioni per garantire una doppia tenuta del premistoppa



CRYOGENIC STEM EXTENSION / ESTENSIONE STELO CRIOGENICA

Special valve and stem execution with 250 mm elongation, suitable for valve usage in cryogenic conditions / Costruzione stelo e valvola con prolunga H 250 mm, idonea ad utilizzo valvola con fluidi criogenici.



LOCKING DEVICE / DISPOSITIVO DI BLOCCAGGIO ALTO

Device suitable to safety lock the valve in open or closed position. Can be assembled also on field. FOR INSULATED VALVES / Dispositivo, montabile anche in campo, atto a lucchettare la valvola in posizione di aperto/chiuso. PER VALVOLE COIBENTATE



LOCKING DEVICE / DISPOSITIVO DI BLOCCAGGIO BASSO

Device suitable to safety lock the valve in open or closed position. Can be assembled also on field / Dispositivo, montabile anche in campo, atto a lucchettare la valvola in posizione di aperto/chiuso





TRANSPORTATION (RAIL & ROAD) VALVE MARKET / VALVOLA PER IL SETTORE TRASPORTI (ROTAIA E GOMMA)

Starting from a standard design, A68 T-PED fulfills all requirements coming from high demanding applications and market: easy inline maintenance, wide range of facing connections available, all suitable to be assembled on rail and road tank with locking devices and additional safety devices / Sviluppata a partire da un design standard, la A68 T-PED soddisfa i requisiti di un mercato con applicazioni severe e particolari: facilità di manutenzione, ampia gamma di flangiature disponibili, adatta ad essere assemblata su serbatoi (stradali e ferroviari) con lucchetti e fermi sicurezza aggiuntivi.

FEATURES / CARATTERISTICHE

- **Body Materials: casting (ASTM A351 CF8M / ASTM A216 WCB) or forged bar (ASTM A350 LF2 / A479 316/316L) /** Materiali corpo: fusione (ASTM A351 CF8M / ASTM A216 WCB) o barra (ASTM A350 LF2 / A479 316/316L)
- **Size from DN 40 to DN 100 /** Diametro: da DN 40 a DN 100
- **Rating: PN 16 o PN 40 /** Rating: PN 16 o PN 40
- **Available face to face /** Scartamenti disponibili: DIN 3202 F4 / F5 / F1
- **Available connections /** Connessioni disponibili: RF, Spigot and Recess (Type E/F) EN1092-1
- **Available for heating jacket application /** Disponibile per applicazione camicia di riscaldamento
- **Virgin PTFE gaskets /** Guarnizioni in PTFE vergine (PN 16 non Fire Safe)
- **PTFE + Graphoil gaskets /** Guarnizioni in PTFE + Graphoil (PN 40 Fire Safe)
- **Available with stem chevron ring for aggressive chemical products /** Disponibile con pacco a V sullo stelo per prodotti chimici aggressivi
- **Valve PN 40: Fire Safe Certified /** Valvola PN 40: Certificata Fire Safe EN10497

CERTIFICATION / CERTIFICAZIONE

- **Valve covered by T-PED certification according to ADR/RID and EN 14432:2014, produced under I.I.S (in-house inspection service) /** Valvola coperta da certificazione di tipo T-PED secondo ADR/RID e EN14432 e sottoposta a I.I.S (in-house inspection service)



Cert. Nr. ADR/RID/ADN-T-AFV 002/004-17-ITA



For cost and lead time contact Alfa Valvole / Per extra costo e tempi di fornitura contattare Alfa Valvole

68 T-PED

OTHERS CERTIFICATION / ALTRE CERTIFICAZIONI

- M61455/20, M61456/20, M61457/20 e M61458/20

certification for the use of valves on road tanks for transportation of hazardous goods in liquid status, approved by CPA (italian agency for transport regulation) / Certificazioni per l'utilizzo delle valvole su cisterne stradali per trasporto di merci pericolose allo stato liquido, omologato presso il CPA (Centro Prove Autoveicoli - Motorizzazione)

INVOLVED VALVES / VALVOLE INTERESSATE:

- A68 PN 16, DN 40-50-80-100 (also FS execution / Anche esecuzione FS)
- A68 PN 40, DN 40-50-80 (also FS execution / Anche esecuzione FS)

ADR/RID

Certifications for hazardous liquefied gas transportation / Certificazione per il trasporto di gas liquefatti pericolosi.

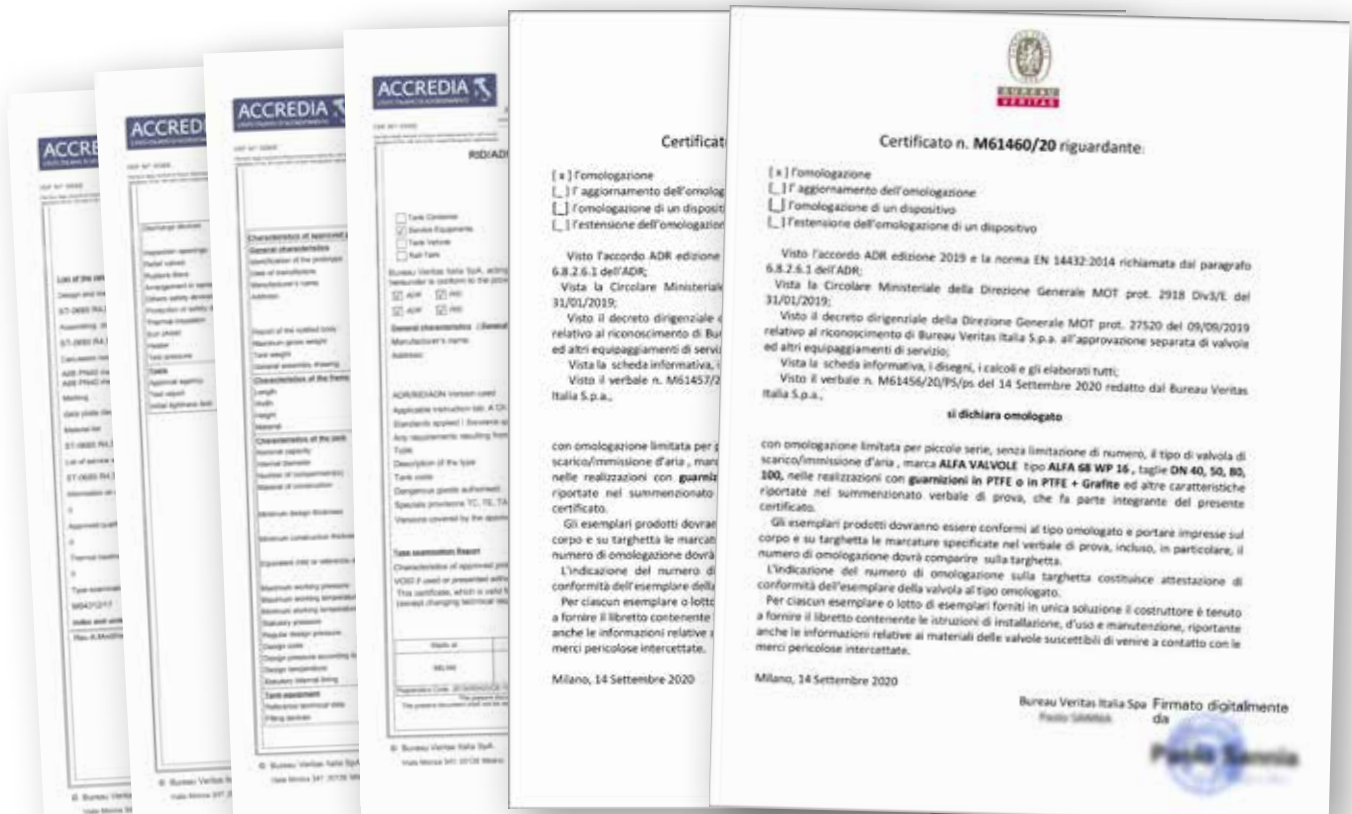

DOUBLE BLOCK & BLEED VALVES

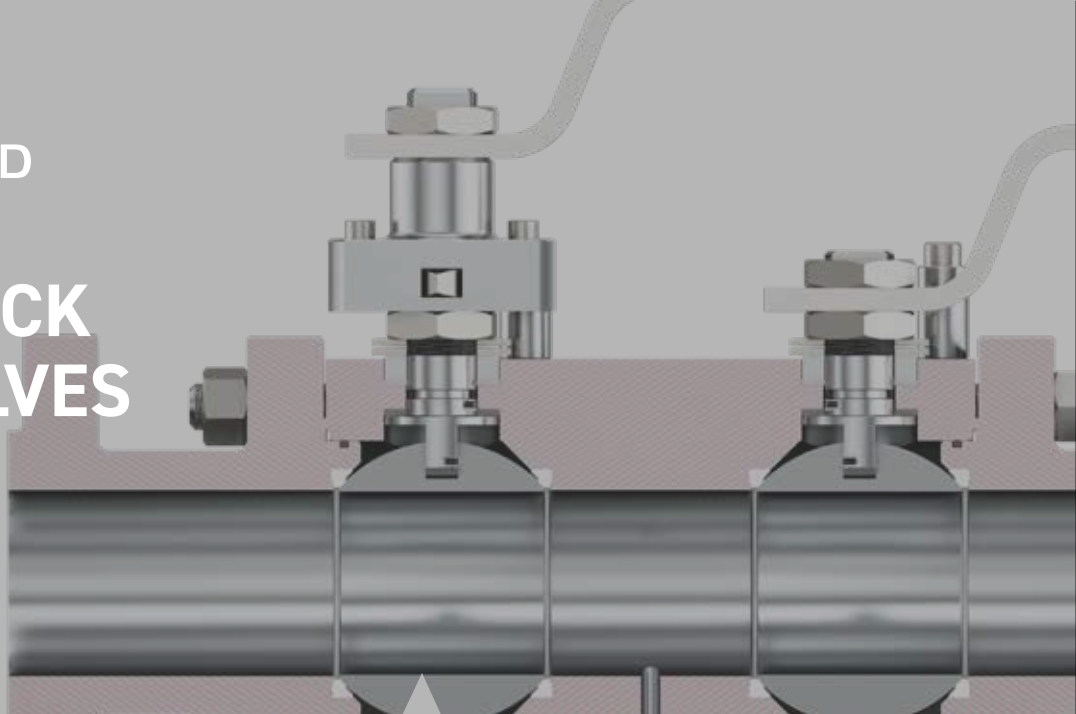

The double block and bleed isolation system requires two in-line isolation valves and a bleed valve, used to drain or vent trapped fluid between the two closure elements in order to safely isolate the downstream pipe / Il sistema di isolamento doppio blocco e spurgo prevede due valvole di isolamento in linea e una valvola di spurgo, utilizzata per drenare o sfiatare il fluido intrappolato tra i due elementi di chiusura al fine di isolare in sicurezza il tubo a valle.

MAIN SECTOR / SETTORI PRINCIPALI

- Oil & gas terminals / Terminali petroliferi
- Refining / Raffinazione
- Chemical & petrochemical / Chimico e petrolchimico
- Offshore oil & gas production / Piattaforme petrolifere e produzione gas
- Process and power production / Centrali elettriche

MAIN FEATURES / CARATTERISTICHE PRINCIPALI

- Anti blow out/low emission systems / Stelo anti espulsione
- Fire safe and anti-static design / Configurazione fire safe e antistatica
- Independent ball and stem / Sfera e stelo indipendenti

ADVANTAGES / VANTAGGI

- Minimized leak / Perdite minimizzate
- Increased line structural integrity / Aumento integrità strutturale
- Increased reliability of the system / Aumento affidabilità del sistema
- Space and weight saving / Dimensioni e peso ridotti
- Saving cost of product and installation / Diminuzione dei costi di produzione ed installazione
- ESDV+MOV or ESDV+XV configurations / Configurazione ESDV+MOV o ESDV+XV



ALFA 615 DBB ANSI 1500

1 side RJ DN 25 - 1 side NPT-F
 Bleeding: needle valve + plug
 Hand lever operated
 1 lato RJ DN 25 - 1 lato NPT-F
 spurgo: valvola a spillo
 + otturatore azionamento
 manuale



ALFA 64 DBB ANSI 150

DN 25, floating type, RF
 Bleeding: A64 DN 25 ANSI150 RF
 Actuated operated (main & bleed)
 DN 25, flottante, RF
 sfiato: A64 DN 25 ANSI 150RF
 attuata

DOUBLE BLOCK & BLEED VALVES

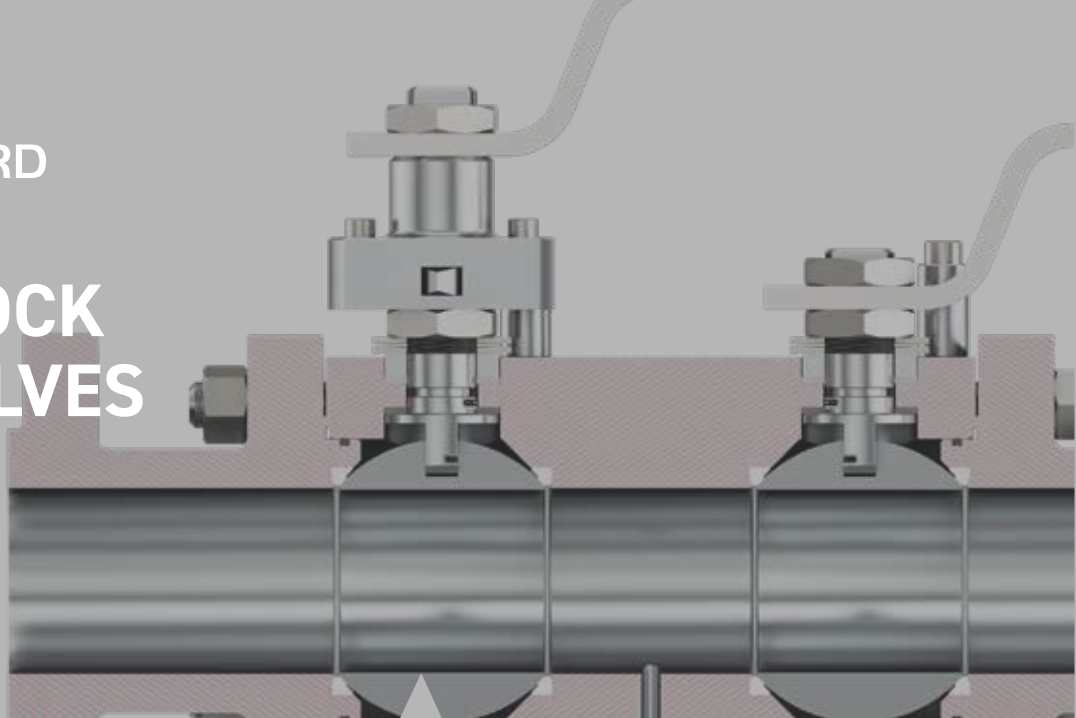

SIZE AND RATING AVAILABLE / DIMENSIONI E PRESSIONI DISPONIBILI

RATING/PRESSIONI	SIZE/DIMENSIONI
150/300	1/2" - 8"
600	1/2" - 4"
900/1500/200	1/2" - 1 1/2"

OPTIONAL EXECUTIONS AVAILABLE / ESECUZIONI OPZIONALI DISPONIBILI

- Operator/Manovra:** **Lever (same side or opposite side) /** Leva (stesso lato o opposte)
Gearbox (same side or opposite side) / Riduttore (stesso lato o opposti)
- Bleeder/Sfiato:** **Floating ball valve, our ALFA 20T / ALFA 22EV screwed to the valve body /** Valvola a sfera flottante ALFA 20T / ALFA 22EV avvitata al corpo valvola
Floating ball valve, or Series 6 bolted to the valve body / Valvola a sfera flottante SERIE 6 imbullonata al corpo valvola
Needle valve screwed into the valve body with bleed / Valvola a spillo avvitata nel corpo valvola completa di sfiato
- Inlet/Outlet:** **All combinations (RF/RJ/NPT/WELDED CONNECTIONS) /** Tutte le combinazioni sono possibili (RF/RJ/NPT/connessioni saldate)



ALFA T2 DBB ANSI900

DN 80x50, trunnion mounted, RF
 Bleeding: threaded plug
 Hand lever operated
 DN 80x50, imperniata, RF
 sfiato: tappo filettato



ALFA 606 DBB ANSI1600

DN 80, floating type, RF
 Bleeding: A20T DN 20 800lbs
 Hand lever operated
 DN 80, flottante, RF
 sfiato: A20T DN 20 800lbs
 azionamento manuale

ALFA 64P ANSI 150 (on request PN 10-16)

8" ≤ DN ≤ 12" / 200 ≤ DN ≤ 300

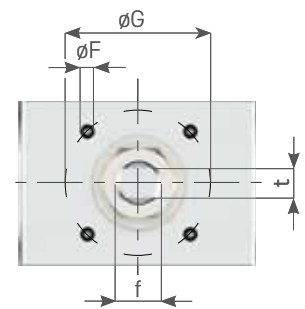
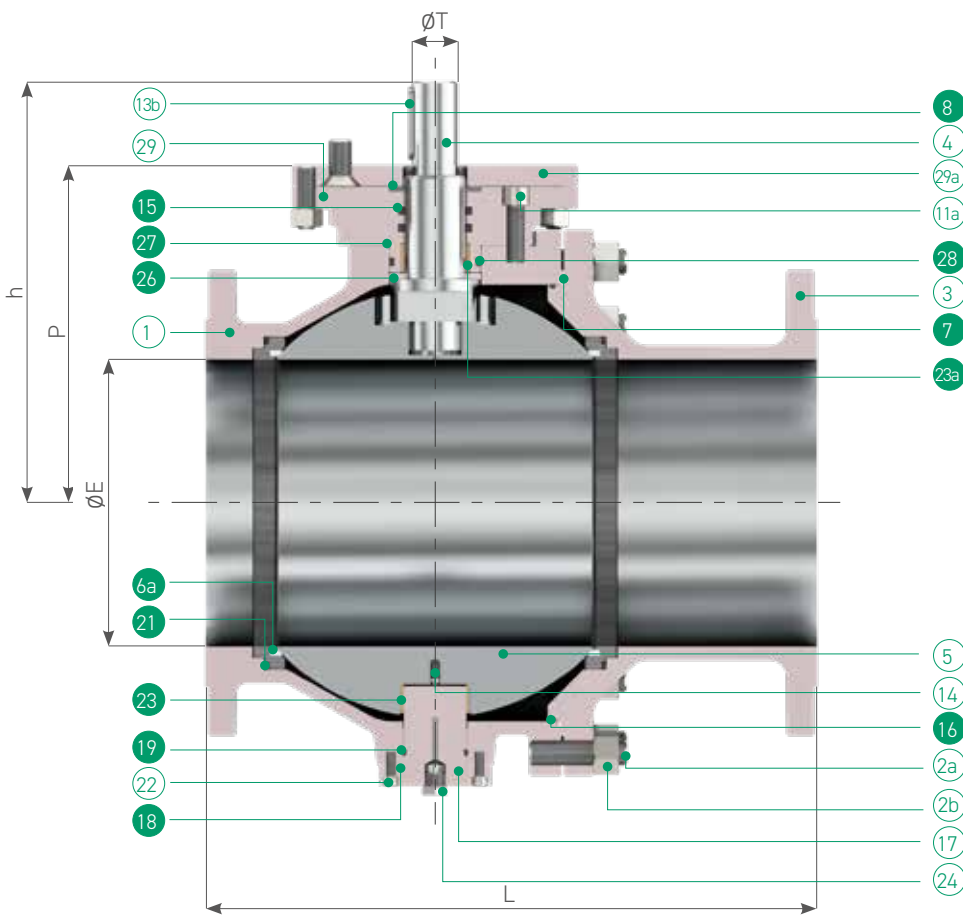

DN 200
Actuator - valve coupling /
Accoppiamento valvola - attuatore
ISO 5211

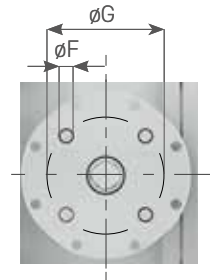

DN 250 - 300
Actuator - valve coupling /
Accoppiamento valvola - attuatore
ISO 5211

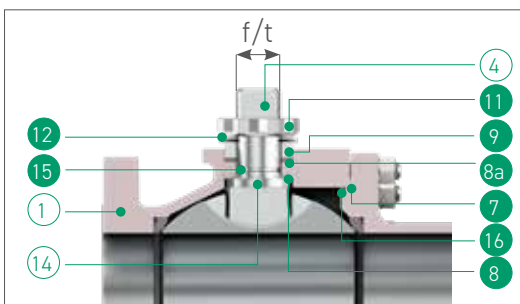

DN 200

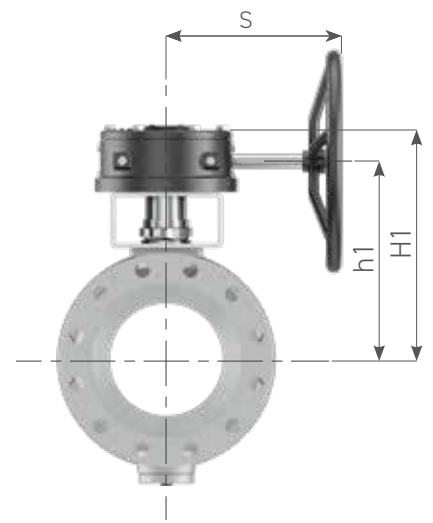
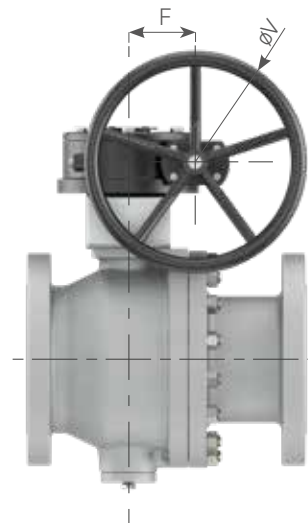

ALFA 64P ANSI 150

Standard valve materials / Materiali costruzione valvola standard

PART NAME PARTICOLARE		Q.TY Q.TA'	CARBON STEEL (TRIM CS)	CARBON STEEL (TRIM SS)	STAINLESS STEEL
1	body corpo	1	ASTM A216WCB	ASTM A216WCB	ASTM A351 CF8M
2a	stud tirante	4/8	ASTM A193 B7		ASTM A193 B8M
2b	nut dado	4/8	ASTM A194 2H		ASTM A194 8M
3	closure chiusura	1	ASTM A216 WCB		ASTM A351 CF8M
4	stem stelo	1	AISI 4140 ENP	ASTM A182 F316	
5	ball sfera	1	ASTM A105 + ENP	ASTM A351 CF8M	
6a	seat ring + insert seggio + inserto	2	ASTM A105 + R.P.T.F.E.	ASTM A479 F316 + R.P.T.F.E.	
7	1 st body gasket guarnizione corpo int.	1	GRAPHOIL		
8	washer bussola	1	P.T.F.E. + 15% GRAFITE		
8a	stem gasket guarnizione stelo	2	P.T.F.E. + 15% GRAFITE (DN=200)		
9	gland premitreccia	1	Carbon Steel Zinc Coated	Stainless Steel 316	
11	stem nut dado stelo	2	Cl. 8	A4-40 (AISI 316)	
11a	grand plate screw viti flangia premitreccia	4	A4-70 (AISI 316)		
12	spring washer molla a tazza	2	51CrV4 Zinc Coated	AISI 316	
13b	key linguetta	1	AISI 1040		
14	antistatic device dispositivo antistatico	2	ASTM A479 F316		
15	stem O-ring O-ring stelo	1	VITON		
16	body O-ring O-ring corpo	1	VITON		
17	trunnion perno	1	ASTM A105 ENP	ASTM A479 F316	
18	trunnion gasket guarnizione perno	1	GRAPHOIL		
19	trunnion O-ring O-ring perno	1	VITON		
21	seat O-ring O-ring seggio	2	VITON		
22	cap screw vite perno	4	A4-70 (AISI 316)		
23	ball bushing boccola sfera	1	DU-DRY		
23a	stem bushing boccola a stelo	1	DU-DRY		
24	drain plug tappo di drenaggio	1	AISI 316		
26	stem washer rondella stelo	1	PTFE+GRAP. / DU-DRY		
27	gland plate gasket guarnizione premitreccia	1	GRAPHOIL		
28	gland plate O-ring O-ring premitreccia	1	VITON		
29	gland plate premitreccia	1	ASTM A105	ASTM A479 F316	
29a	adapter plate flangia motore	1	ASTM A105	ASTM A479 F316	
31	thrust washer rondella sfera	1	DU-DRY		

 Spares parts / Parti di ricambio

DIMENSIONS / DIMENSIONI

DN	200	250	300
ø"	8"	10"	12"
ø E	203	250	300
L	457	533	610
h	345	367	411
P	200	293	339
f/t/øT	52/30/-	ø 40	ø 40
Kg *	150	180	237
ISO 5211	F16	F16	F16
ø F	M16	M20	M20
ø G	140	165	165
h1	354	447	499
H1	408	500	552
F	92	92	103
S	305	305	360
ø V	500	500	600

All valves are standard assembled with gearbox / Tutto le valvole sono assemblate di serie con riduttore
* Handwheel gearbox included / Comprensivo di riduttore manuale



ALFA 60P ANSI 300 (on request PN 25-40)

8" ≤ DN ≤ 10" / 200 ≤ DN ≤ 250

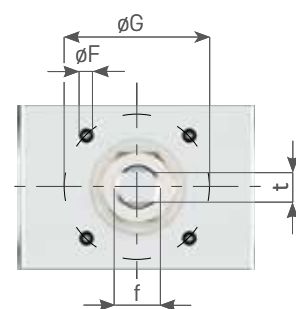
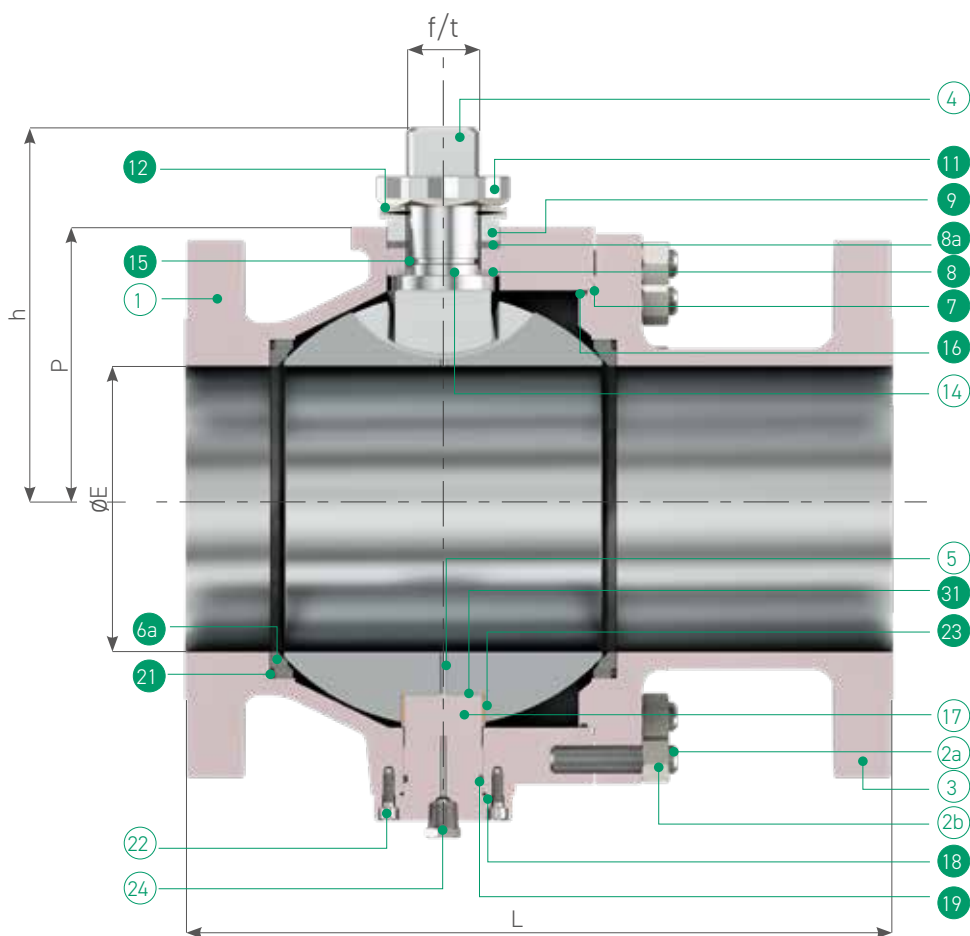

DN 200
Actuator - valve coupling /
Accoppiamento valvola - attuatore
ISO 5211

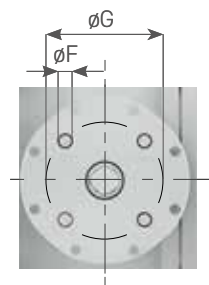

DN 250
Actuator - valve coupling /
Accoppiamento valvola - attuatore
ISO 5211

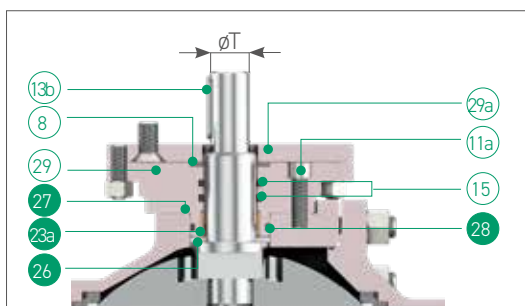

DN 250

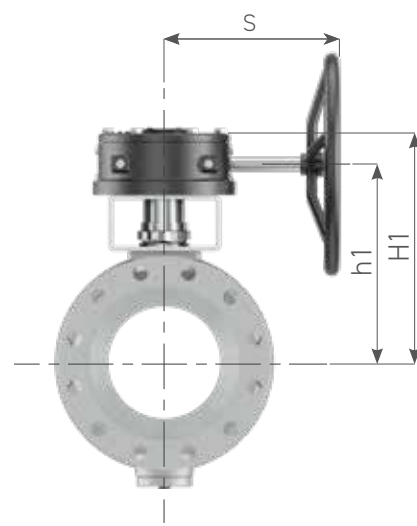
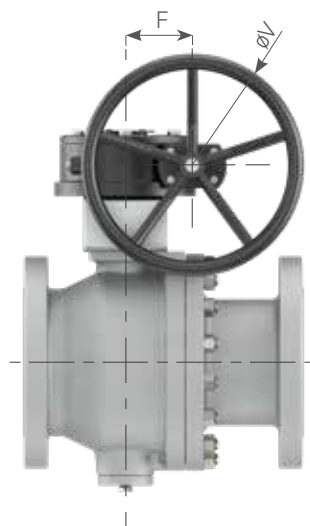

ALFA 60P ANSI 300

Standard valve materials / Materiali costruzione valvola standard

PART NAME PARTICOLARE		Q.TY Q.TA'	CARBON STEEL (TRIM CS)	CARBON STEEL (TRIM SS)	STAINLESS STEEL
1	body corpo	1	ASTM A216WCB	ASTM A216WCB	ASTM A351 CF8M
2a	stud tirante	4/8	ASTM A193 B7		ASTM A193 B8M
2b	nut dado	4/8	ASTM A194 2H		ASTM A194 8M
3	closure chiusura	1	ASTM A216 WCB		ASTM A351 CF8M
4	stem stelo	1	AISI 4140 ENP	ASTM A182 F316	
5	ball sfera	1	ASTM A105 + ENP	ASTM A351 CF8M	
6a	seat ring + insert seggio + inserto	2	ASTM A105 + R.P.T.F.E.	ASTM A479 F316 + R.P.T.F.E.	
7	1 st body gasket guarnizione corpo int.	1	GRAPHOIL		
8	washer bussola	1	P.T.F.E. + 15% GRAFITE		
8a	stem gasket guarnizione stelo	2	P.T.F.E. + 15% GRAFITE (DN=200)		
9	gland premitreccia	1	Carbon Steel Zinc Coated	Stainless Steel 316	
11	stem nut dado stelo	2	Cl. 8	A4-40 (AISI 316)	
11a	grand plate screw viti flangia premitreccia	4	A4-70 (AISI 316)		
12	spring washer molla a tazza	2	51CrV4 Zinc Coated	AISI 316	
13b	key linguetta	1	AISI 1040		
14	antistatic device dispositivo antistatico	2	ASTM A479 F316		
15	stem O-ring O-ring stelo	1	VITON		
16	body O-ring O-ring corpo	1	VITON		
17	trunnion perno	1	ASTM A105 ENP	ASTM A479 F316	
18	trunnion gasket guarnizione perno	1	GRAPHOIL		
19	trunnion O-ring O-ring perno	1	VITON		
21	seat O-ring O-ring seggio	2	VITON		
22	cap screw vite perno	4	A4-70 (AISI 316)		
23	ball bushing boccola sfera	1	DU-DRY		
23a	stem bushing boccola a stelo	1	DU-DRY		
24	drain plug tappo di drenaggio	1	AISI 316		
26	stem washer rondella stelo	1	PTFE+GRAP. / DU-DRY		
27	gland plate gasket guarnizione premitreccia	1	GRAPHOIL		
28	gland plate O-ring O-ring premitreccia	1	VITON		
29	gland plate premitreccia	1	ASTM A105	ASTM A479 F316	
29a	adapter plate flangia motore	1	ASTM A105	ASTM A479 F316	
31	thrust washer rondella sfera	1	DU-DRY		

 Spares parts / Parti di ricambio

DIMENSIONS / DIMENSIONI

DN	200	250
ø"	8"	10"
ø E	203	250
L	502	568
h	270	367
P	200	293
f/ t / øT	52/30 / -	- / ø 40
Kg. *	172	219
ISO 5211	F14	F16
ø F	M16	M20
ø G	140	165
h1	354	453
H1	408	506
F	92	103
S	305	360
ø V	500	600

* Handwheel gearbox included / Comprensivo di riduttore manuale



(P,T) DIAGRAMS

Diagrammi (P,T)

ALFA 64P/60P

Pressure - temperature diagrams shows the standard working condition (pressure & temperature) for the specific valve. These conditions refer to a continuous use. For transitions for peak condition, an overload until 10% is accepted. In these cases we suggest anyway to contact engineering dept.

I diagrammi pressione - temperatura identificano le condizioni di uso contemporanee di pressione e temperatura a cui la valvola può operare. Tali condizioni sono da riferirsi ad un uso continuo. Per condizioni transitorie o di picco, scostamenti fino al 10% sono tollerati. In tali casistiche consultare comunque l'ufficio tecnico Alfa Valvole.



P85S SEATS /SEDI IN P85S

- **PTFE filled with 25% Carbon before transformation** / PTFE addizionato con carica di Carbone al 25% prima della trasformazione
- **Carbon filling guarantees a constant response in continuous service until 220°C with point of 250°C** / L'aggiunta del carbone garantisce performances stabili in servizio continuo fino a 220°C, con picchi di 250°C
- **Lubricating properties and dimensional stability equal to virgin PTFE** / Potere lubrificante, stabilità dimensionale del PTFE vergine
- **Enhanced mechanical, deformation and wear resistance compared to virgin PTFE** / Resistenza meccanica, alla deformazione e all'usura superiore al PTFE vergine

ALFA 64P

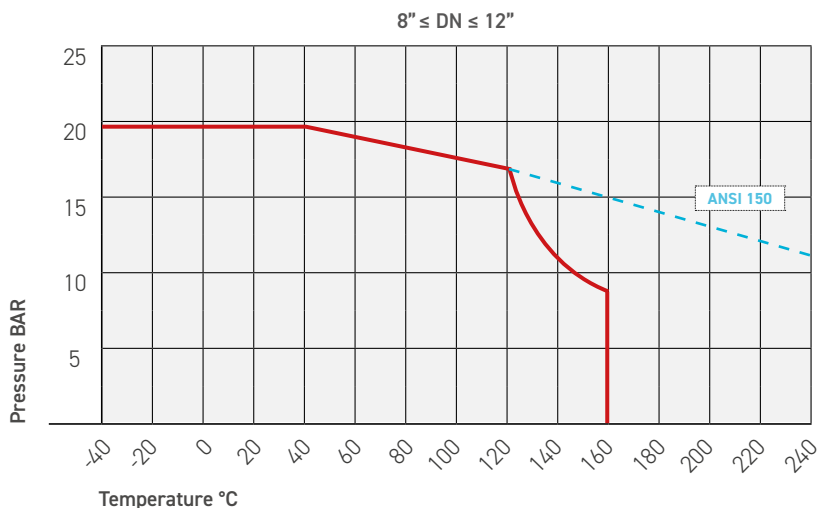

DN	ALL
P max @ Tmax	8 bar @ 160°C

ALFA 60P

8" ≤ DN ≤ 10"

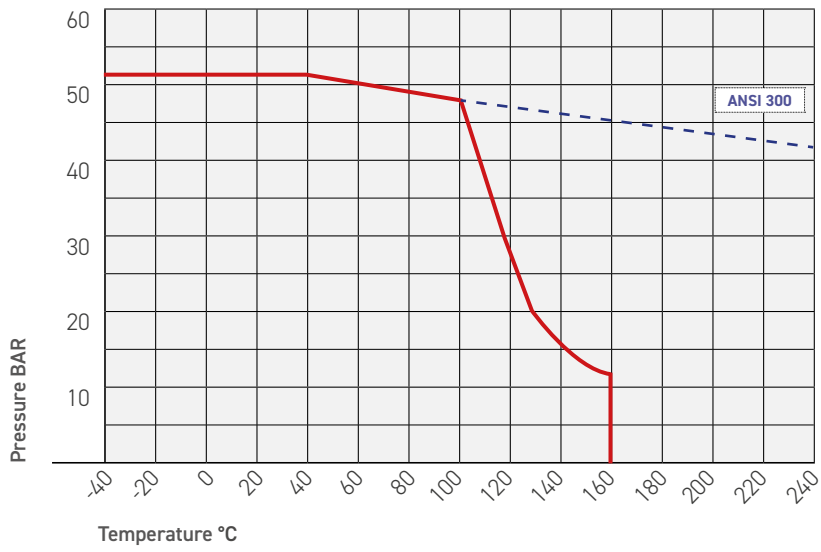

DN	ALL
P max @ Tmax	12 bar @ 160°C

A60P DN 200 ANSI 150 with electric actuator / A60P DN 200 ANSI 150 con attuatore elettrico



